



Review

What Is Worth Knowing in Interventional Practices about Medical Staff Radiation Exposure Monitoring: A Review of Recent Outcomes of EURADOS Working Group 12

Paolo Ferrari ^{1,*}, Mercè Ginjaume ², Oliver Hupe ³, Una O'Connor ⁴, Filip Vanhavere ⁵, Elena Bakhanova ⁶, Frank Becker ⁷, Lorenzo Campani ¹, Eleftheria Carinou ⁸, Isabelle Clairand ⁹, Dario Faj ¹⁰, Jan Jansen ¹¹, Zoran Jovanović ¹², Željka Knežević ¹³, Dragana Krstić ¹², Francesca Mariotti ¹, Marta Sans-Merce ¹⁴, Pedro Teles ¹⁵ and Milena Živković ¹²



Citation: Ferrari, P.; Ginjaume, M.; Hupe, O.; O'Connor, U.; Vanhavere, F.; Bakhanova, E.; Becker, F.; Campani, L.; Carinou, E.; Clairand, I.; et al. What Is Worth Knowing in Interventional Practices about Medical Staff Radiation Exposure Monitoring: A Review of Recent Outcomes of EURADOS Working Group 12. *Environments* **2022**, *9*, 53. <https://doi.org/10.3390/environments9040053>

Academic Editors: Gaetano Licitra, Mauro Magnoni and Gian Marco Contessa

Received: 16 March 2022

Accepted: 12 April 2022

Published: 18 April 2022

Publisher's Note: MDPI stays neutral with regard to jurisdictional claims in published maps and institutional affiliations.



Copyright: © 2022 by the authors. Licensee MDPI, Basel, Switzerland. This article is an open access article distributed under the terms and conditions of the Creative Commons Attribution (CC BY) license (<https://creativecommons.org/licenses/by/4.0/>).

- ¹ ENEA—Radiation Protection Institute, 40129 Bologna, Italy; lorenzo.campani@enea.it (L.C.); mariotti.francesca@enea.it (F.M.)
 - ² Institut de Tècniques Energètiques, Universitat Politècnica de Catalunya, 08034 Barcelona, Spain; merce.ginjaume@upc.edu
 - ³ Physikalisch-Technische Bundesanstalt (PTB), 38116 Braunschweig, Germany; oliver.hupe@ptb.de
 - ⁴ St. James's Hospital, D08 NHY1 Dublin, Ireland; uoconnor@stjames.ie
 - ⁵ SCK-CEN, Belgian Nuclear Research Centre, 2400 Mol, Belgium; filip.vanhavere@sckcen.be
 - ⁶ National Research Center for Radiation Medicine, 04050 Kyiv, Ukraine; elena.bakhanova@gmail.com
 - ⁷ KIT, Institute for Nuclear Waste Disposal, 76344 Eggenstein-Leopoldshafen, Germany; frank.becker@kit.edu
 - ⁸ EEAE, Greek Atomic Energy Commission, 15341 Athens, Greece; eleftheria.carinou@eeae.gr
 - ⁹ IRSN, Institute Radiological Protection and Nuclear Safety, 92260 Fontenay-Aux-Roses, France; isabelle.clairand@irsn.fr
 - ¹⁰ Faculty of Medicine, University of Osijek, 31000 Osijek, Croatia; dariofaj@mefos.hr
 - ¹¹ Radiation, Chemical and Environmental Hazards (RCE), UKHSA, Oxford OX11 0RQ, UK; jan.jansen@phe.gov.uk
 - ¹² Faculty of Science, University of Kragujevac, 34000 Kragujevac, Serbia; z.jovanovic@kg.ac.rs (Z.J.); dragana@kg.ac.rs (D.K.); milena.zivkovic@pmf.kg.ac.rs (M.Ž.)
 - ¹³ RBI, Ruđer Bošković Institute, 10000 Zagreb, Croatia; zeljka.knezevic@irb.hr
 - ¹⁴ CHUV, Centre Hospitalier Universitaire Vaudois, 1011 Lausanne, Switzerland; marta.sansmerce@hcuge.ch
 - ¹⁵ Departamento de Física e Astronomia, Faculdade de Ciências da Universidade do Porto, 4169-007 Porto, Portugal; ppteles@fc.up.pt
- * Correspondence: paolo.ferrari@enea.it

Abstract: EURADOS (European Radiation Dosimetry Group) Working Group 12 (WG12) SG1 activities are aimed at occupational radiation protection and individual monitoring in X-ray and nuclear medicine practices. In recent years, many studies have been carried out in these fields, especially for interventional radiology and cardiology workplaces (IC/IR). The complexity of the exposure conditions of the medical staff during interventional practices makes the radiation protection and monitoring of the exposed workers a challenging task. The scope of the present work is to review some of the main results obtained within WG12 activities about scattered field characterization and personal dosimetry that could be very useful in increasing the quality of radiation protection of the personnel, safety, and awareness of radiation risk. Two papers on Monte Carlo modelling of interventional theater and three papers on active personal dosimeters (APDs) for personnel monitoring were considered in the review. More specifically, Monte Carlo simulation was used as the main tool to characterize the levels of exposure of the medical staff, allowing to determine how beam energy and direction can have an impact on the doses received by the operators. Indeed, the simulations provided information about the exposure of the operator's head, and the study concluded with the determination of an eye-lens protection factor when protection goggles and a ceiling shielding are used. Moreover, the review included the results of studies on active personal dosimeters, their use in IC/IR workplaces, and how they respond to calibration fields, with X-ray standard and pulsed beams. It was shown that APDs are insensitive to backscatter radiation, but some of them could not respond correctly to the very intense pulsed fields (as those next to the patient in interventional practices). The measurements during interventional procedures showed the potential capability of the employment of APDs in hospitals.

Keywords: interventional radiology; interventional cardiology; medical staff radiation dose monitoring; Monte Carlo simulations; dosimetry; health physics; electronic personal dosimeters; medical staff ionizing radiation exposure

1. Introduction

The complexity of the exposure conditions of the medical staff during interventional practices makes radiation protection and monitoring of the involved workers a challenging task [1–3]. The scattered radiation field produced by the patient from the primary X-ray beam and propagating towards the operators can be mitigated by wearable protective means (aprons and collars) and a properly positioned shielding [4]. Notwithstanding that, because of the increasing numbers of procedures performed in a year, due to their diagnostic and therapeutic effectiveness [5], the annual doses in personnel performing this kind of practice are among the highest registered for workers in the medical field [1,2,6,7]. For instance, increasing knowledge about exposure conditions and optimizing radiation protection are fundamental to fulfill the implementation of the ALARA (as low as reasonably achievable) principle for those workers.

If it is possible to assess dose in the hand and finger employing ring or bracelet dosimeters [8,9], effective dose estimation, evaluated through a personal equivalent dose, $H_p(10)$ measurements, is even more complex. A protective apron and collar only partially protect the operator's body from the scattered radiation. Indeed, the operator's exposure is dependent on the X-ray tube projection, which is changed during practice, according to diagnostic needs. For these reasons, a single dosimeter put under the apron or on the apron (in various positions, at the waist or breast or at clavicle height) cannot mimic the exact exposure situation of the operator. Different correction factors are available in the literature, to be applied to a single dosimeter reading, or algorithms that can be employed when two dosimeters (one on and one under the apron) are worn simultaneously [10,11].

The re-evaluation of the tissue reaction and the radiosensitivity of the eye lens [12,13] and the subsequent annual dose limit reduction introduced in the EU 2013/59/Euratom directive [14] involved an update on the methodology of the eye lens dose estimation in interventional practices [15,16].

Lastly, the introduction of electronic dosimeters and online devices for operator dose monitoring [17–20], on the one hand, opens new perspectives for individual dosimetry, and on the other hand, it requires better knowledge of their behavior in interventional fields and a thorough check of their reliability.

For all these reasons, a great part of the EURADOS (European Radiation Dosimetry Group) Working Group 12 Dosimetry in medical imaging (WG12) activities has been devoted to performing a series of studies on the exposure of medical staff performing interventional practices. The scope of the present work is presenting a review of the main results obtained in WG12 and published in the literature aimed at characterizing the irradiation field and the exposure of the operator's head and studying the response of an electronic dosimeter in interventional practices. Some new outcomes, not yet published, are reported to complete the discussion of the results.

2. Simulation of the Scattered Radiation Field and the Operator Doses

2.1. Interventional Theater Modelling

Monte Carlo (MC) simulations, mainly obtained by the MCNP (Monte Carlo N-Particle) code family [21,22], supplied the primary data for the scattered field study. A modified version of a MIRD (Medical Internal Radiation Dose Committee) type model [23] was used to mimic the patient and two operators. The two operators were covered with a 0.5 mm Pb layer, properly shaped, representing the protective apron and collar, and their arms were bent to reproduce a "realistic" position. The kerma area product transmission chamber (KAP), normally employed to monitor the X-ray emission during the clinical exam,

was reproduced as a simple air parallelepiped put at a given distance from the source. The KAP calculated values were used to normalize the dose-calculated values. The dosimeters, put in selected positions on the operators, were simulated as simple air-filled spheres, with a 1 cm radius. The corresponding dose equivalent was calculated by folding the photon fluence reaching the sphere with the ICRU (International Commission on Radiation Units and Measurements) conversion coefficients [24].

Initially, the geometry included only a single operator and the undercouch shielding; then a second operator was added on the right of the first operator (Figure 1). The two operators' positions were changed, as their "direction" (rotating the models on their vertical axis toward the patient head or feet), and a 0.5 or 1 mm rectangular lead ceiling shielding was opportunely positioned between the operators and scattering source when needed.

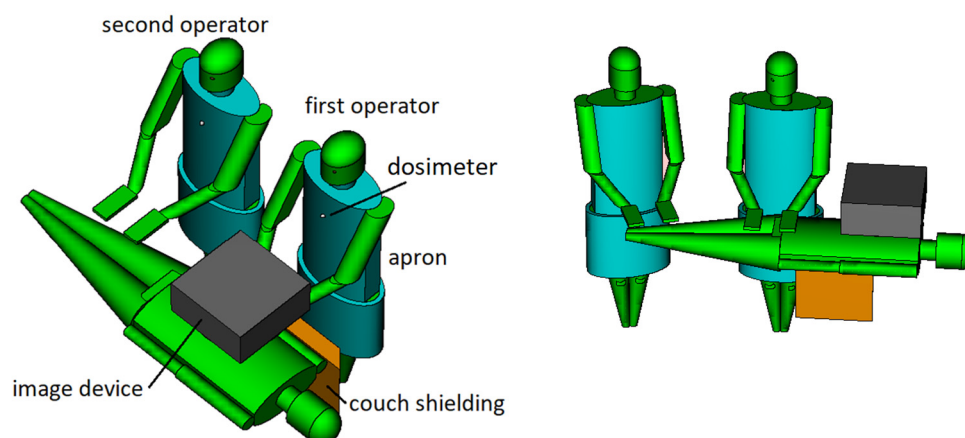

Figure 1. Monte Carlo simulated scenarios with two operators and the patient (PA X-ray beam projection). Interventional cardiology (IR) on the left (first operator next to the image device), interventional cardiology (IC) on the right (first operator near the right patient's leg).

The X-ray tube beam qualities were simulated according to the IPEM (Institute of Physics and Engineering in Medicine) spectral data [25]. Different beam qualities (changing kV and copper and aluminum filtrations) were employed, and, besides posteroanterior (PA), different beam projections were considered (left anterior oblique (LAO), right anterior oblique (RAO), cranial (CRA), caudal (CAU)) at various impinging angles (25°, 30°, 45°, 60°, 90°).

2.2. Scattering Field Evaluation and Operator's Whole Body Exposure

During the European ORAMED (Optimization of Radiation Protection of Medical Staff) [26] project, the effect of the LAO and CRA projections in increasing the exposure of the operator with respect to the RAO projections was demonstrated [4]. These effects were confirmed in more recent works, and in particular, it was seen how the image device, in interventional radiology (IR) practice, can have a "protective" effect on the first operator [27].

The personal dose equivalent, $H_p(10)$, was calculated through dosimeters placed at three heights (waist, breast, and neck) on the apron, along the sagittal median plane of the anthropomorphic model, for sake of simplicity. The study [27] allowed investigating the differences in the scattering field reaching the two operators during IR practice. A detailed analysis of the scattering can be found in the cited paper here, as can be seen in Figure 2, for PA projection (the most common projection employed in those procedures). The highest dose is registered at the level of the waist, and it decreases moving toward the neck. Because of the distances with the patient and beam, the second operator's doses were lower than the first with the only exception of the dosimeter put on the neck. Here, the values were more similar due to the reduced amount of radiation coming directly from the patient and because the possible increase of the contribution derived from the

multiple scattering. Indeed, as said above, the image device can play a role in reducing the exposure of the first operator upper parts. An analogous exposure condition was recently investigated, even in the presence of a ceiling shielding, by the group of Nowak et al. [28], who published the spectra of the scattered photons in selected positions in an interventional theater. The complexity of the situation of the scatter reaching the operators in IR can be guessed also considering what happens to the LAO 25° (left anterior oblique 25°) projection (Figure 3). In that case, the image device does not offer an additional protection to the first operator, and the doses registered at the neck (these data have not been published previously) depend more directly on the distances from the beam (Figure 4). In that case, the doses to the first operator are higher. As can be seen, indeed, the doses for the LAO projections are higher than those evaluated for the PA projection due to the direction of the X-ray beam impinging on the patient, which increases the backscatter component directed towards the operator, as already demonstrated in a previous work [4].

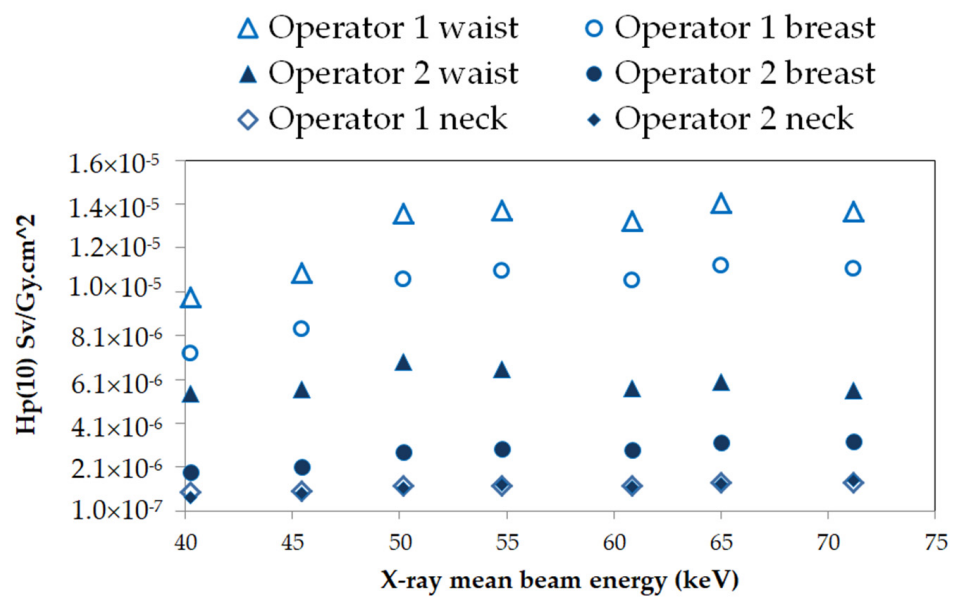

Figure 2. The response of a dosimeter put on the operator's apron at three different heights in interventional radiology procedures (MC simulations for PA projection, data taken from [27]).

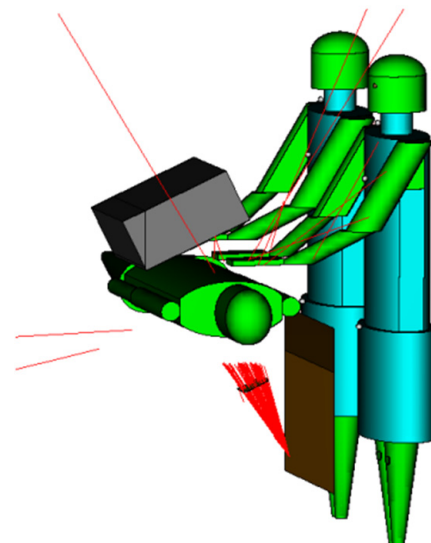

Figure 3. Monte Carlo simulated irradiation in interventional radiology for the LAO 25° projection.

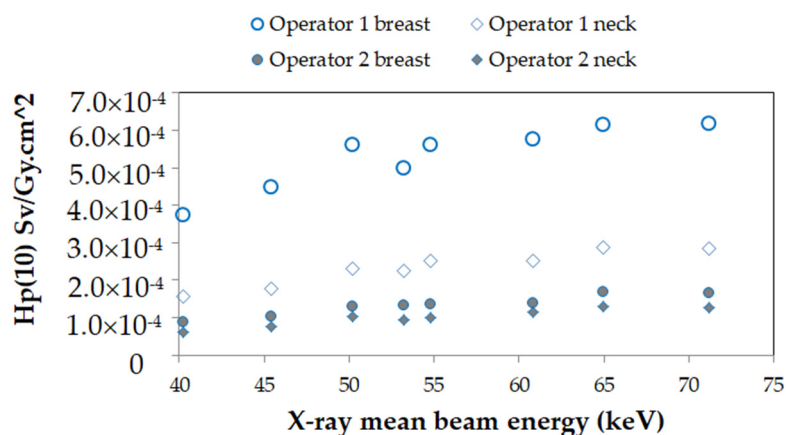

Figure 4. The response of a dosimeter put on the operator’s apron. MC simulations for the LAO 25° projection).

In the case of IR, the exposure of the first operator, registered by a dosimeter put on the breast, on an apron, is of the order of $10 \mu\text{Sv}/\text{Gy}\cdot\text{cm}^2$, a value in agreement with those reported by Leyton et al. [29] and Martin [2], and that can be reduced by about two orders of magnitude when an additional shielding is used, as simulation and measurement demonstrated [27].

Because the anthropomorphic models were based on a MIRD male phantom [23], it was possible only to evaluate a sort of “male effective dose” (the effective dose per se would require the average of the doses evaluated in the female and male models). The calculated “male effective dose” for the first operator ranges from $0.03 \mu\text{Sv}/\text{Gy}\cdot\text{cm}^2$ to $0.4 \mu\text{Sv}/\text{Gy}\cdot\text{cm}^2$, with the X-ray mean energy varying from 40 keV to 70 keV, and from $0.015 \mu\text{Sv}/\text{Gy}\cdot\text{cm}^2$ to $0.1 \mu\text{Sv}/\text{Gy}\cdot\text{cm}^2$ for the second operator [27]. Such estimates are in agreement with the data published by Kim et al. [30].

Some algorithms available in the literature employ $H_p(10)$, evaluated by only one dosimeter put on the protective collar, to estimate the effective dose [11]. In particular, the NCRP report suggests dividing $H_p(10)$ by 21 [31], and McEwan suggests multiplying it by 0.08 [32] (i.e., dividing it by 12.5). These two factors can be compared with those that can be calculated from WG12 studies in IR.

In Figure 5, the ratios between $H_p(10)$, evaluated with the neck (unshielded) dosimeter, and the “male effective dose” versus beam energy are reported (these data have not been published previously). They vary from 3 to 25 for the first operator and from 15 to 45 for the second operator, and their mean values are 10 and 27, respectively. The factors are lower for the first operator because the doses evaluated in the collar are comparable between the two operators, but the effective dose for the first operator is higher; thus the “correction factor” is lower. It is worth recalling that, due to the geometries and distances from the patient, the position of the second operator (near the patient’s right leg) can mimic the position of the first operator during interventional cardiology (IC) procedures (through femoral access; see also Figure 1). Thus, the mean values obtained from the simulations can justify the discrepancy of the correction factors in the two papers cited above, considering that they could have been evaluated in different conditions (cardiology vs. radiology, beam energy, distances, etc.) and that they are plausible, taking into account the variability of the exposure due to the complex scattered field reaching the operators during interventional practices.

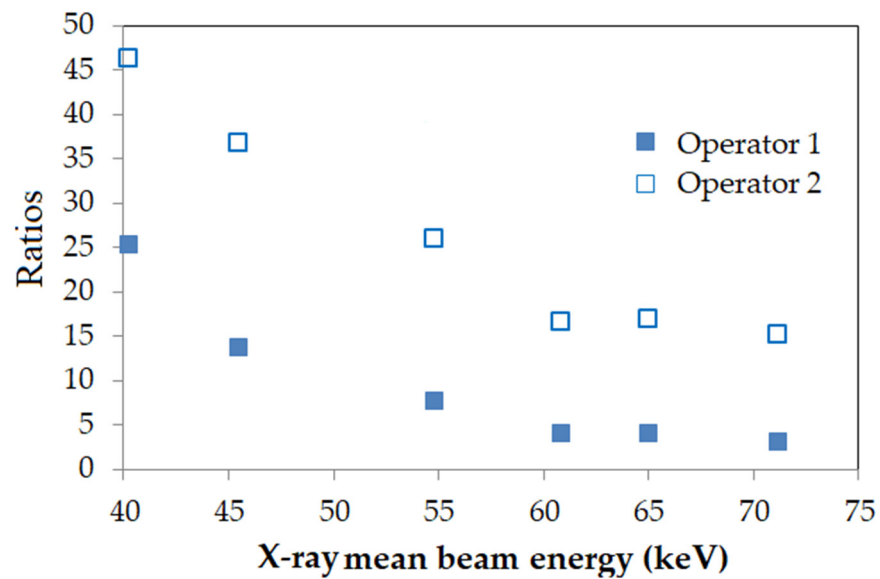

Figure 5. Ratio between $H_p(10)$ evaluated with a neck unshielded dosimeter and calculated “male effective dose” versus X-ray mean energy (MC simulations for PA projection).

In Figure 6, the ratios between $H_p(10)$, evaluated with a dosimeter put on the breast (unshielded), and the “male effective dose” are reported, and they vary from 25 to 125 for the first operator and from 25 to 190 for the second operator. The large variability of those factors for the effective dose evaluation with a single dosimeter is coherent (for X-ray mean beam energies higher than 45 keV) with the range of values reported by Jarvinen et al. [33].

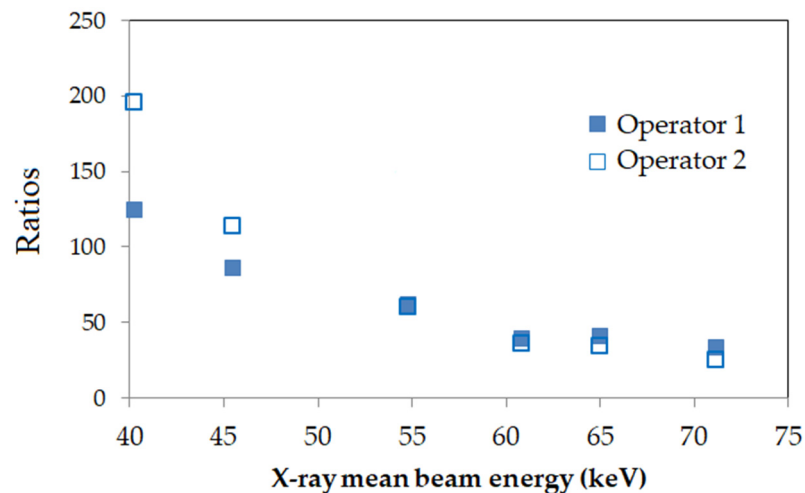

Figure 6. Ratio between $H_p(10)$ evaluated with unshielded dosimeter put on the apron at the breast level and calculated “male effective dose” versus X-ray mean energy (MC simulations for PA projection).

2.3. Exposure of the Operator’s Head and Eye Lens

In studying the scattering radiation impinging on an IR operator in WG12, a particular attention was addressed to the head and eye lens exposure. In an early work [23], considering only one operator and femoral access position in IC procedures, the exposure of the eye lens was investigated, taking into account different X-ray qualities, projections, and protective means (goggles and ceiling shielding). The simulation demonstrated how

the efficacy of the protective goggles was very dependent on their shape and ability to attenuate the radiation coming from below, in agreement with experimental data produced by Domienik and Brodecki [34]. In order to determine the direction of incidence of the scattered radiation towards the eye lens, the geometry was simplified, modelling the eye as a simple sphere of the eye-bulb size, divided in spherical sectors by median axial, sagittal, and coronal planes (more details can be found in the cited paper [23]). It was shown that properly shaped goggles can reduce the absorbed dose up to nearly a factor of 10 (but this is highly dependent on their shape; see also [35]), and that is particularly valid for the left eye lens, which usually receives twice the amount of the radiation reaching the right eye lens. The latter was in fact reached by the radiation scattered inside the head of the operator, an effect suggested by Martin [36] and proven in the cited work [23]. Protection of the eye lens is achievable, in a less straightforward way, through the ceiling shielding, provided that it is correctly positioned with respect to the beam and the scattering source. In the same study, it was shown how in case of a LAO 90° projection, with the X-ray tube on the left side of the first operator, the protective efficiency of the shielding is reduced by a factor of the order of 10 when the shielding is not correctly placed (i.e., shifted in a position that does not protect the operator from the scattered radiation [23]). Similar considerations have been drawn for the other projections tested and for radial access and can be stressed to improve the compliance of operators to radioprotection strategies [37,38].

Analogous remarks on the effectiveness of the shielding can be made for the protection of the head (brain) of the operator involved in interventional practices. Recent studies have put the attention on the possible increase in the malignant late effect of radiation in IR and cardiology personnel due to the left part of the brain exposure [39–42]. In order to study that exposure, the brain of the numerical models was properly segmented to roughly reproduce human brain lobes (frontal, temporal, parietal, and occipital), a cerebellum, and a stem [43]. The absorbed doses in these brain sectors, normalized to the KAP values, were calculated for the two operators of IR, in the absence of a ceiling shielding (a condition not so infrequent in practice) for different X-ray beam qualities and projections (PA, RAO 25°, LAO 25°, CAR 25°).

Even in the approximations introduced by the rigidity of the models (considering the variability of the real scenario), in interventional radiology, because of the position with respect to the X-ray beam, the left and right brain parts of the first operator are affected by nearly the same amount of radiation, with a maximum corresponding to the frontal lobes (as expected from a previous study on the incidence direction of the scattered radiation on the head [23]). On the other hand, for the second operator, placed on the right side of the first operator, in a position that can resemble the position of the first operator in IC, the left part of the brain receives twice the amount of the radiation received by the right part (in agreement with what happens with the eye lens in the same situation). The highest values were obtained for the LAO and PA projections, then for the CRA and RAO projections.

Depending on the beam quality, projection, and operator position, in the absence of a ceiling shielding, the range of the absorbed doses to the brain varies between 0.1 Gy·cm² and 0.7 μGy/Gy·cm² for the first operator in IR and between 0.1 Gy·cm² and 1.1 μGy/Gy·cm² for the second operator. It is worth recalling here that, because of the peculiar exposure condition in IR, the first operator is nearer to the patient but partially shielded by the image device in the PA projection; thus the absorbed dose to the brain of the first operator can be lower than the absorbed dose to the brain of the second operator. Considering a typical KAP value ranging from 20 Gy·cm² to 40 Gy·cm² [9], one gets about 2 μGy to 28 μGy for the first and 4 μGy to 44 μGy for the second operator per procedure, respectively. These values are consistent with the (48 +/− 28) μGy per procedure reported by Watson et al. [44] and with those recently evaluated using plastic phantoms and dosimeters by Hattori et al. [45].

Taking into account 200 to 500 procedures in a year [5], the annual absorbed dose can vary between 0.4 mGy and 22 mGy. The latter value is in agreement with the exposure considered by Reeves in “The Brain Study” [41].

3. Testing Active Personal Dosimeters in Interventional Practices

A reliable evaluation of the IR and IC medical staff exposure is of primary concern, and this can be pursued even taking advantage of new technologies, such as electronic personal devices and online measuring systems [18–20] possibly coupled with fast Monte Carlo codes [17]. For that reason, WG12 performed a series of studies addressed to analyze the behavior of the APDs (active personal dosimeters) in interventional practices.

The study was divided into three lines of investigation: (a) the response of some commercially available APDs was tested in primary standard dosimetry laboratories, employing continuous and pulsed X-ray field (like those used in interventional practices); (b) the responses of both APDs and passive-type dosimeters (thermoluminescence (TLD), radio-photoluminescence (RPL), optically stimulated luminescence (OSL), and film dosimeter) were studied in secondary standard dosimetry laboratories, employing the standard ISO (International Organization for Standardization) water slab phantom [46] covered by a “typical” interventional radiology operator’s protective apron, determining the effect of such protective means on the dosimeter response; (c) a measuring campaign in an interventional theater was performed, with operators wearing a device that housed both an RPL dosimeter and an APD, to guarantee that they were exposed simultaneously in the analogous conditions.

3.1. APD Response in Continuous and Pulsed X-ray Field

Commercially available APDs were tested in a calibration laboratory at KIT (Karlsruhe Institute of Technology), NIOM (Nofer Institute of Occupational Medicine), and PTB (Physikalisch-Technische Bundesanstalt) with ^{60}Co , ^{137}Cs sources, and selected RQR X-ray beams (in continuous and pulsed emission) [47]. All the measurements were performed on an ISO water slab phantom in ISO reference conditions [46]. The behavior of the dosimeters against an increasing dose rate was checked, showing that some of them tended to underestimate doses because they were not able to correct for the electronic pile-up at a certain dose rate [48]. The IEC (International Electrotechnical Commission) is preparing a technical report describing a general procedure for testing the suitability of a dosimeter for pulsed radiation fields, IEC/DTS 63050 [49]. Due to the pulsation of the radiation field, the response will not change by more than $\pm 20\%$. Additionally, the smallest acceptable value for the maximum measurable dose rate of a dosimeter will be at least 1 Sv/h. Both criteria were only fulfilled by 3 of 10 tested APD types (see the cited paper [48] for more details).

3.2. Effect of the Protective Apron on a Dosimeter’s Response

The response of passive (TLD, OSL, RPL, and films) and active dosimeters was tested in secondary standard dosimetry laboratories with ^{137}Cs and selected RQR X-ray beam qualities (continuous emission). The dosimeter was placed on an ISO water slab phantom, and the measurement was repeated, putting an apron or an equivalent thickness of lead on the phantom between the slab and the dosimeter, mimicking the wearing condition of the dosimeter put on the apron in interventional procedures. The measurements were coupled with Monte Carlo simulations. In the presence of a protective apron on the slab, the study showed a reduction of the order of 30% for the dose reading in the case of passive dosimeters. The dose readings were less affected by the apron for electronic dosimeters due to the reduced sensitivity to backscatter of the latter device [50]. This behavior is clearly visible in Figure 7, where the ratios of the responses of the tested dosimeters placed on the calibration phantom, with and without the lead layer, were reported.

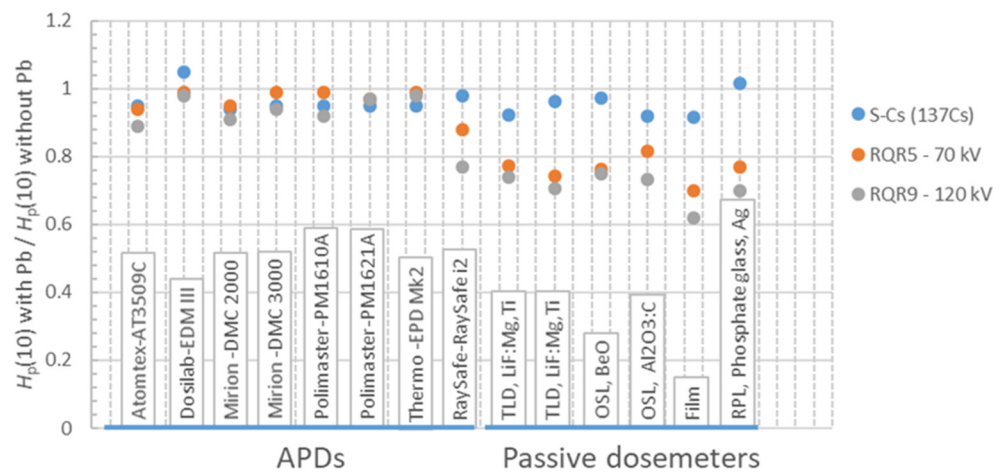

Figure 7. Ratios of $H_p(10)$ with lead apron and $H_p(10)$ without lead apron of different types of active and passive dosimeters placed on ISO calibration phantoms for different beam and radiation qualities (data taken from [50]).

3.3. Comparison of the Responses of Active and Passive Dosimeters in the Hospital

With the aim of testing simultaneously passive (RPL) and active dosimeters in the hospital, a simple device housing the two dosimeters (Figure 8) and to be worn on an apron was distributed among physicians performing interventional procedures. A measurement campaign was performed comparing the doses received by the two types of dosimeters. Because direct reading was possible in the active dosimeter, after a certain level of cumulated dose, that was registered, the passive dosimeter was removed and substituted, and the active dosimeter reset for a new measurement. The comparison of the readings of the passive and active dosimeters showed a certain spread in the results, particularly at lower doses, and, in general, an underestimation of the doses in the case of the active ones. In particular, it was observed that the three tested APD, EPD Mk2.3, DMC-3000, and RaySafe-i2 had, on average, a 30%, 10%, and 10%, respectively, lower response than the reference RPL passive dosimeter. Due to the fact they were worn in a random variety of standard interventional procedures, with a random range of energies, angles, and pulse field characteristics, the standard deviations ranged from 40% to 50%, but the tendency is clear for the three devices (more details can be found in the published paper [51]).



Figure 8. The simple device employed the measurements in the hospital during the interventional procedures. The APD was attached to the upper section of the device, while the lower section hosted the RPL.

The causes of that behavior can be associated with the pulsed field and the slightly different heights of the two dosimeters that can play a role in such discrepancy. A series of recommendations for APD employment in the medical field have been published [52].

4. Conclusions

EURADOS WG12 activities are driven to radiation protection in the medical field. The works reviewed in the present paper aimed at a better knowledge of personnel radiation exposure in interventional practices. These studies were performed through MC simulations and measurements, in calibration laboratories and hospitals, and brought results that can be used to increase the quality of radiation protection of personnel and the awareness of radiation risk.

Two studies of the scattering around the operator's head [23,43] provided information about the exposure of the eye lens and the operator's brain, offering strategies to optimize radiation protection. They stated that the exposure of the eye lens can be reduced by a factor of 2 up to nearly a factor of 10 employing proper goggles (i.e., goggles adherent to the operator face, capable of absorbing the radiation coming from the bottom (see also [34]), but goggles with an unsuited shape offer a lower protection level [35,36]). A reduction of the order of 10 can be obtained also from a ceiling shielding (see also [53]), but it is important to underline that a non-optimal placement of the shielding, with respect the main source of the scatter, can heavily reduce its protection capability. Thus to avoid exposure of the operator's eyes and head, a correct shielding positioning should be stressed [54], particularly when goggles are not used, to improve radiation safety and awareness [37]. The same ceiling shielding can offer a protection also for the operator's brain that during an interventional procedure can receive exposure ranging from $0.1 \mu\text{Gy}/\text{Gy}\cdot\text{cm}^2$ and $1 \mu\text{Gy}/\text{Gy}\cdot\text{cm}^2$ in the absence of a proper shielding, implying absorbed doses that are coherent with those evaluated for long-term effects in medical staff cohorts [40].

A study on operator exposure in interventional radiology [27] allowed a better knowledge of the scattering field in relation to the $H_p(10)$ evaluated with dosimeters put on an apron. During interventional procedures, a dosimeter put on an apron can receive a dose, expressed in terms of $H_p(10)$, of the order of $10 \mu\text{Sv}/\text{Gy}\cdot\text{cm}^2$ per procedure, but the same studies also showed the sensitivity of such kind of evaluation due to the dosimeter's position coupled with the complexity of the scattering scenario.

Indeed, three studies on APDs [48,50,51] considered the opportunity of using these devices. In particular, they showed that during a calibration procedure on a phantom, APDs are insensitive to the backscatter radiation, but some of them could not respond correctly in case of a very intense pulsed X-ray beam. That means that some aspects related to APDs probably deserve supplementary investigations.

Based on the work performed on these devices, a series of recommendations were proposed as a practical guide for hospital users, medical physicists, and radiation protection experts [52].

Future works will be addressed to better assess APDs' response in these pulsed radiation fields and to study the influence of the position of the dosimeter on the operator on the evaluated doses.

A comprehensive document summarizing all the works performed in this field by WG12 is under preparation, and it is expected to be issued soon as a EURADOS technical report.

Author Contributions: Conceptualization and methodology M.G., E.C., O.H., I.C., U.O., M.S.-M., Ž.K., F.V. and P.F., simulations P.F., E.B., F.B., J.J., Z.J., D.K., P.T. and M.Ž., data acquisition and measurements O.H., F.V., L.C., E.C., I.C., D.F., P.F., F.M., M.G., U.O. and Ž.K.; writing—review and editing, P.F., M.G., E.C., E.B., D.F., I.C., J.J., P.T., Ž.K. and F.V. All authors have read and agreed to the published version of the manuscript.

Funding: This research received no external funding.

Data Availability Statement: All the data refer to published study cited throughout the text.

Conflicts of Interest: The authors declare no conflict of interest.

References

1. Covens, P.; Berus, D.; Buls, N.; Clerinx, P.; Vanhavere, F. Personal dose monitoring in hospitals: Global assessment, critical applications and future needs. *Radiat. Prot. Dosim.* **2007**, *124*, 250–259. [CrossRef] [PubMed]
2. Martin, C.J. A review of radiology staff doses and dose monitoring requirements. *Radiat. Prot. Dosim.* **2009**, *136*, 140–157. [CrossRef] [PubMed]
3. Padovani, R.; Rodella, C.A. Staff dosimetry in interventional cardiology. *Rad. Prot. Dosim.* **2001**, *94*, 99–103. [CrossRef]
4. Koukorava, C.; Carinou, E.; Ferrari, P.; Krim, S.; Struelens, L. Study of the parameters affecting operator doses in interventional radiology using Monte Carlo simulations. *Rad. Meas.* **2011**, *46*, 1216–1222. [CrossRef]
5. ESR. European Society of Radiology (ESR) and Cardiovascular and Interventional Radiological Society of Europe (CIRSE). Interventional Radiology in European Radiology Departments: A Joint Survey from the European Society of Radiology (ESR) and the Cardiovascular and Interventional Radiological Society of Europe (CIRSE). Insights into Imaging; 10:16. 2019. Available online: <https://doi.org/10.1186/s13244-019-0698-6> (accessed on 2 February 2022).
6. On behalf of the ICRP; Cousins, C.; Miller, D.L.; Bernardi, G.; Rehani, M.M.; Schofield, P.; Vañó, E.; Einstein, A.J.; Geiger, B.; Heintz, P.; et al. International Commission on Radiological Protection: Radiological protection in cardiology. *Ann. ICRP* **2013**, *42*, 1–125. [CrossRef] [PubMed]
7. Vañó, E.; González, L.; Guibelalde, E.; Fernández, J.M.; Ten, J.I. Radiation exposure to medical staff in interventional and cardiac radiology. *Brit. J. Radiol.* **1998**, *71*, 954–960. [CrossRef] [PubMed]
8. Donadille, L.; Carinou, E.; Brodecki, M.; Domienik, K.; Jankowski, J.; Koukorava, C.; Krim, S.; Nikodemova, D.; Ruiz-Lopez, N.; Sans-Merce, M.; et al. Staff eye lens and extremity exposure in interventional cardiology: Results of the ORAMED project. *Rad. Meas.* **2011**, *46*, 1203–1209. [CrossRef]
9. Nikodemová, D.; Brodecki, M.; Carinou, E.; Domienik, K.; Donadille, L.; Koukorava, C.; Krim, S.; Ruiz-López, N.; Sans-Merce, M.; Struelens, L.; et al. Staff extremity doses in interventional radiology. Results of the ORAMED measurement campaign. *Rad. Meas.* **2011**, *46*, 1210–1215. [CrossRef]
10. Clerinx, P.; Buls, N.; Bosmans, H.; de Mey, J. Double dosimetry algorithm for workers in interventional radiology. *Rad. Prot. Dosim.* **2008**, *129*, 321–327. [CrossRef]
11. Padovani, R.; Foti, C.; Malisan, M.R. Staff dosimetry protocols in interventional radiology. *Rad. Prot. Dosim* **2001**, *94*, 193–196. [CrossRef] [PubMed]
12. International Commission on Radiological Protection. The 2007 recommendations of the International Commission on Radiological Protection. *Ann. ICRP* **2007**, *103*, 2–4.
13. International Commission on Radiological Protection. ICRP Statement on tissue reactions/early and late effects of radiation in normal tissues and organs threshold doses for tissue reactions in a radiation protection context. *Ann. ICRP* **2012**, *41*, 1–322. [CrossRef] [PubMed]
14. Council Directive 2013/59/Euratom of 5 December 2013 Laying down Basic Safety Standards for Protection against the Dangers Arising from Exposure to Ionising Radiation, and Repealing Directives. 89/618/Euratom, 90/641/Euratom, 96/29/Euratom, 97/43/Euratom and 2003/122/Euratom. Available online: <https://eur-lex.europa.eu/eli/dir/2013/59/oj> (accessed on 14 April 2022).
15. Carinou, E.; Ferrari, P.; Ciraj Bjelac, O.; Ginjaume, M.; Sans Merce, M.; O'Connor, U. Eye lens monitoring for interventional radiology personnel: Dosimeters, calibration and practical aspects of Hp(3) monitoring. A 2015 review. *J. Radiol. Prot.* **2015**, *35*, R17–R34. [CrossRef]
16. Ciraj Bjelac, O.; Carinou, E.; Ferrari, P.; Ginjaume, M.; Sans Merce, M.; O'Connor, U. Occupational Exposure of the Eye Lens in Interventional Procedures: How to Assess and Manage Radiation Dose. *J. Am. Coll. Radiol.* **2016**, *3*, 1347–1353. [CrossRef] [PubMed]
17. Abdelrahman, M.; Lombardo, P.; Vanhavere, F.; Seret, A.; Phillips, C.; Covens, P. First steps towards online personal dosimetry using computational methods in interventional radiology: Operator's position tracking and simulation input generation. *Radiat. Phys. Chem.* **2020**, *171*, 108702. [CrossRef]
18. Inaba, Y.; Chida, K.; Kobayashi, R.; Kaga, R.; Zuguchi, M. Fundamental study of a real-time occupational dosimetry system for interventional radiology staff. *J. Radiol. Prot.* **2014**, *34*, N65–N71. [CrossRef] [PubMed]
19. Vañó, E.; Fernandez, J.M.; Sanchez, R. Occupational dosimetry in real time. *Benefits for interventional radiology Rad. Meas.* **2011**, *46*, 1262–1265.
20. Vañó, E.; Sanchez, R.; Fernandez, J.M. Strategies to optimise occupational radiation protection in interventional cardiology using simultaneous registration of patient and staff doses. *J. Radiol. Prot.* **2018**, *38*, 1077–1088. [CrossRef] [PubMed]
21. Pelowitz, D.B. (Ed.) *MCNPX User's Manual*; LA-CP-05-0369; Los Alamos Laboratory: Los Alamos, NM, USA, 2005.
22. Pelowitz, D.B. (Ed.) *MCNP6 User's Manual*; Version 1.0, s LA-CP-13-00634; Los Alamos Laboratory: Los Alamos, NM, USA, 2013.
23. Ferrari, P.; Becker, F.; Carinou, E.; Chumak, V.; Farah, J.; Jovanovic, Z.; Krstic, D.; Morgun, A.; Principi, S.; Teles, P. Monte Carlo study of the scattered radiation field near the eyes of the operator in interventional procedures. *J. Radiol. Prot.* **2016**, *36*, 902–921. [CrossRef]
24. International Commission on Radiation Units and Measurements. *ICRU Report 57 Conversion Coefficients for Use in Radiological Protection against External Radiation*; Oxford University Press: Bethesda, MD, USA, 1996.
25. IPEM. *Catalogue of Diagnostic X ray and Other Spectra*; Scientific Report Series No.78; IPEM: York, UK, 1997.

26. Ginjaume, M.; Vanhavere, F.; Carinou, E.; Gualdrini, G.; Clairand, I.; Sans-Merce, M. (Eds.) International Workshop on Optimization of Radiation Protection of Medical Staff. *ORAMED Rad. Meas.* **2011**, *46*, 11.
27. Ferrari, P.; Becker, F.; Jovanovic, Z.; Khan, S.; Bakhanova, E.; Principi, S.; Krstic, D.; Pierotti, L.; Mariotti, F.; Faj, D. Simulation of $H_p(10)$ and effective dose received by the medical staff in interventional radiology procedures. *J. Radiol. Prot.* **2019**, *39*, 809–824. [[CrossRef](#)] [[PubMed](#)]
28. Nowak, M.; Carbonez., P.; Krauss, M.; Verdun, F.R.; Damet, J. Characterisation and mapping of scattered radiation fields in interventional radiology theatres. *Sci. Rep.* **2020**, *30*, 18754. [[CrossRef](#)] [[PubMed](#)]
29. Leyton, F.; Nogueira, M.S.; Gubolino, L.A.; Pivetta, M.R.; Ubeda, C. Correlation between scatter radiation dose at height of operator's eye and dose to patient for different angiographic projections. *Appl. Radiat. Isot.* **2016**, *117*, 100–105. [[CrossRef](#)] [[PubMed](#)]
30. Kim, K.P.; Miller, D.L.; Berrington de Gonzalez, A.; Balter, S.; Kleinerman, R.A.; Ostroumova, W.; Simon, S.L.; Linet, M.S. Occupational radiation doses to operator performing fluoroscopically-guided procedures. *Health Phys.* **2012**, *103*, 80–99. [[CrossRef](#)]
31. National Council on Radiation Protection and Measurements Use of Personal Monitors to Estimate Effective Dose Equivalent to Workers for External Exposure to Low-LET Radiation. Bethesda, MD: NCRP NCRP Report No. 122. 1995. Available online: <https://ncrponline.org/shop/reports/report-no-122-use-of-personal-monitors-to-estimate-effective-dose-equivalent-and-effective-dose-to-workers-for-external-exposure-to-low-let-radiation-1995/> (accessed on 14 April 2022).
32. McEwan, A.C. Assessment of occupational exposure in New Zealand from personal monitoring records. *Radiat. Prot. Australas.* **2000**, *17*, 60–66.
33. Jarvinen, H.; Buls, N.; Clerinx, P.; Jansen, J.; Miljanic, S.; Nikodemova, D.; Ranogajec-Komor, M.; d'Errico, F. Overview of double dosimetry procedures for the determination of the effective dose to the interventional radiology staff. *Radiat. Prot. Dosim.* **2008**, *129*, 333–339. [[CrossRef](#)]
34. Domienik, J.; Brodecki, M. The effectiveness of lead glasses in reducing the doses to eye lenses during cardiac implantation procedures performed using x-ray tubes above the patient table. *J. Radiol. Prot.* **2016**, *36*, N19–N25. [[CrossRef](#)]
35. Van Rooijen, B.D.; de Haan, M.W.; Das, M.; Arnoldusse, C.W.K.P.; de Graaf, R.; van Zwam, W.H.; Backes, W.H.; Jeuken, C.R.L.P.N. Efficacy of Radiation Safety Glasses in Interventional Radiology Cardio. *Vasc. Interv. Radiol.* **2014**, *37*, 1149–1155.
36. Martin, C.J.; Magee, J.S.; Sandblom, V.; Almén, A.; Lundh, C. Eye dosimetry and protective eyewear for interventional clinicians. *Radiat. Prot. Dosim.* **2015**, *165*, 284–288. [[CrossRef](#)]
37. Dominiek, J.; Brodecki, M.; Carinou, E.; Donadille, L.; Jankowski, J.; Koukorava, C.; Krim, S.; Nikodemova, D.; Ruiz-Lopez, N.; Sans-Merce, M.; et al. Extremity and eye lens doses in interventional radiology and cardiology procedures: First results of the ORAMED project. *Radiat Prot Dosim.* **2011**, *144*, 442–447. [[CrossRef](#)]
38. Sailer, A.M.; Vergoossen, L.; Paulis, L.; van Zwam, W.H.; Das, M.; Wildberger, J.E.; Jeukens, C.R. Personalized Feedback on Staff Dose in Fluoroscopy-Guided Interventions: A New Era in Radiation Dose Monitoring. *Cardiovasc. Intervent. Radiol.* **2017**, *40*, 1756–1762. [[CrossRef](#)]
39. Picano, E.; Vano, E.; Domenici, L.; Bottai, M.; Thierry-Chef, I. Cancer and non-cancer brain and eye effects of chronic low-dose ionizing radiation exposure. *BMC Cancer* **2012**, *12*, 157. [[CrossRef](#)] [[PubMed](#)]
40. Roguin, A.; Goldstein, J.; Bar, O.; Goldstein, J.A. Brain and neck tumours among physicians performing interventional procedures. *Am. J. Cardiol.* **2013**, *111*, 1368–1372. [[CrossRef](#)] [[PubMed](#)]
41. Reeves, R.R.; Ang, L.; Bahadorani, J.; Naghi, J.; Dominguez, A.; Palakodeti, V.; Tsimikas, S.; Patel, M.P.; Mahmud, E. Invasive Cardiologists are exposed to greater left sided cranial radiation: The Brain study. *JACC Cardiovasc. Interv.* **2015**, *8*, 1197–1206. [[CrossRef](#)] [[PubMed](#)]
42. Kithara, C.M.; Linet, M.S.; Balter, S.; Miller, D.L.; Rajaraman, P.; Cahoon, E.K.; Velazquez-Kronen, R.; Simon, S.L.; Little, M.P.; Doody, M.M.; et al. Occupational radiation exposure and deaths from malignant intracranial neoplasms of the brain and CNS in U.S. radiologic technologists, 1983–2012. *Am. J. Roentgenol.* **2017**, *208*, 1278–1284. [[CrossRef](#)]
43. Ferrari, P.; Jovanovic, Z.; Bakhanova, E.; Becker, F.; Krstic, D.; Jansen, J.; Principi, S.; Teles, P.; Clairand, I.; Knezevic, Ž. Absorbed dose in the operator's brain in interventional radiology practices: Evaluation through KAP value conversion factors. *Phys. Med.* **2020**, *76*, 177–181. [[CrossRef](#)]
44. Watson, L.E.; Riggs, M.W.; Bourland, P.D. Radiation exposure during cardiology fellowship training. *Health Phys.* **1997**, *73*, 690–693. [[CrossRef](#)]
45. Hattori, S.; Monzen, H.; Tamura, M.; Kosaka, H.; Nakamura, Y.; Nishimura, Y. Estimating radiation exposure of the brain of a physician with a protective flap in interventional radiology: A phantom study. *J. Appl. Clin. Med. Phys.* **2022**, *23*, e13532. [[CrossRef](#)]
46. *UNE EN ISO 4037-3; 2021 Radiological Protection—X and Gamma Reference Radiation for Calibrating Dosimeters and Doserate Meters and for Determining Their Response as a Function of Photon Energy—Part 3: Calibration of Area and Personal Dosimeters and the Measurement of Their Response as a Function of Energy and Angle of Incidence (ISO 4037-3:2019)*. ISO: Geneva, Switzerland. Available online: <https://www.iso.org/standard/66874.html> (accessed on 14 April 2022).
47. *IEC 61267:2005; Medical Diagnostic X-ray Equipment—Radiation Conditions for use in the Determination of Characteristics*. IEC: Geneva, Switzerland. Available online: <https://webstore.iec.ch/publication/5079> (accessed on 14 April 2022).

48. Hupe, O.; Friedrich, S.; Vanhavere, F.; Marcin, B. Determining the dose rate dependence of different active personal dosimeters in standardized pulsed and continuous radiation fields. *Rad. Prot. Dosim.* **2019**, *187*, 345–352. [[CrossRef](#)]
49. International Electrotechnical Commission. Radiation Protection Instrumentation–Dosimeters for Pulsed Fields of Ionizing Radiation. International Draft Technical Specification IEC/DTS 63050, Community Draft. Available online: https://webstore.iec.ch/preview/info_iects63050%7Bed1.0%7Den.pdf (accessed on 14 April 2022).
50. Ginjaume, M.; Carinou, E.; Marcin, B.; Clairand, I.; Domienik-Andrzejewska, J.; Exner, L.; Ferrari, P.; Jovanović, Z.; Krstic, D.; Principi, S.; et al. Effect of the radiation protective apron on the response of active and passive personal dosimeters used in interventional radiology and cardiology. *J. Radiol. Prot.* **2019**, *39*, 97–112. [[CrossRef](#)]
51. Vanhavere, F.; Carinou, E.; Clairand, I.; Ciraj-Bjela, O.; De Monte, F.; Domienik-Andrzejewska, J.; Ferrari, P.; Ginjaume, M.; Hrsak, H.; Hupe, O.; et al. The use of active personal dosimeters in interventional workplaces in hospitals: Comparison between active and passive dosimeters worn simultaneously by medical staff. *Rad. Prot. Dosim.* **2020**, *188*, 22–29. [[CrossRef](#)] [[PubMed](#)]
52. O'Connor, U.; Carinou, E.; Clairand, I.; Ciraj-Bjelac, O.; De Monte, F.; Domienik-Andrzejewska, J.; Ferrari, P.; Ginjaume, M.; Hršak, H.; Hupe, O.; et al. Recommendations for the use of active personal dosimeters (APDs) in interventional workplaces in hospitals. *Phys. Med.* **2021**, *87*, 131–135. [[CrossRef](#)] [[PubMed](#)]
53. Maeder, M.; Brunner-La Rocca, H.P.; Wolber, T.; Ammann, P.; Roelli, H.; Rohner, F.; Rickli, H. Impact of a Lead Glass Screen on Scatter Radiation to Eyes and Hands in Interventional Cardiologists. *Catheter. Cardiovasc. Interv.* **2006**, *67*, 18–23. [[CrossRef](#)] [[PubMed](#)]
54. Martin, C.J. Eye lens dosimetry for fluoroscopically guided clinical procedures: Practical approaches to protection and dose monitoring. *Radiat. Prot. Dosim.* **2016**, *169*, 286–291. [[CrossRef](#)] [[PubMed](#)]