

Prehospital randomised assessment of a mechanical compression device in out-of-hospital cardiac arrest (PARAMEDIC): a pragmatic, cluster randomised trial and economic evaluation

Simon Gates, Ranjit Lall, Tom Quinn, Charles D Deakin, Matthew W Cooke, Jessica Horton, Sarah E Lamb, Anne-Marie Slowther, Malcolm Woollard, Andy Carson, Mike Smyth, Kate Wilson, Garry Parcell, Andrew Rosser, Richard Whitfield, Amanda Williams, Rebecca Jones, Helen Pocock, Nicola Brock, John JM Black, John Wright, Kyee Han, Gary Shaw, Laura Blair, Joachim Marti, Claire Hulme, Christopher McCabe, Silviya Nikolova, Zenia Ferreira and Gavin D Perkins



**National Institute for
Health Research**

Prehospital randomised assessment of a mechanical compression device in out-of-hospital cardiac arrest (PARAMEDIC): a pragmatic, cluster randomised trial and economic evaluation

Simon Gates,^{1*} Ranjit Lall,¹ Tom Quinn,²
Charles D Deakin,³ Matthew W Cooke,^{1,4}
Jessica Horton,¹ Sarah E Lamb,^{1,5}
Anne-Marie Slowther,¹ Malcolm Woollard,²
Andy Carson,⁶ Mike Smyth,^{1,6} Kate Wilson,⁶
Garry Parcell,⁶ Andrew Rosser,⁶ Richard Whitfield,⁷
Amanda Williams,⁷ Rebecca Jones,⁷ Helen Pocock,³
Nicola Brock,³ John JM Black,³ John Wright,^{8,9}
Kye Han,⁸ Gary Shaw,⁸ Laura Blair,⁸ Joachim Marti,¹⁰
Claire Hulme,¹⁰ Christopher McCabe,¹¹
Silviya Nikolova,¹⁰ Zenia Ferreira¹⁰ and
Gavin D Perkins^{1,4}

¹Warwick Clinical Trials Unit, University of Warwick, Coventry, UK

²Surrey Peri-operative Anaesthesia Critical Care Collaborative Research Group, Faculty of Health and Medical Sciences, University of Surrey, Guildford, UK (current address: Faculty of Health, Social Care and Education, Kingston University London and St George's, University of London, London, UK)

³South Central Ambulance Service NHS Foundation Trust, Otterbourne, UK

⁴Heart of England NHS Foundation Trust, Birmingham, UK

⁵Oxford Clinical Trials Research Unit, University of Oxford, Oxford, UK

⁶West Midlands Ambulance Service NHS Foundation Trust, Brierley Hill, UK

⁷Welsh Ambulance Services NHS Trust, St Asaph, UK

⁸North East Ambulance Service NHS Foundation Trust, Newcastle upon Tyne, UK

⁹Royal Victoria Infirmary, Newcastle upon Tyne, UK

¹⁰Academic Unit of Health Economics, Leeds Institute of Health Sciences, University of Leeds, Leeds, UK

¹¹Department of Emergency Medicine Research, University of Alberta, Edmonton, AB, Canada

*Corresponding author

Declared competing interests of authors: Simon Gates was a member of the National Institute for Health Research (NIHR) Efficacy and Mechanism Evaluation Board until February 2015 and the NIHR Standing Advisory Committee on Clinical Trials Units until December 2014 and is a member of the Medical Research Council Methodology Research Programme Panel. Sarah E Lamb is chairperson of the NIHR Health Technology Assessment Clinical Evaluation and Trials Board and member and chairperson of the NIHR Clinical Trials Unit Standing Advisory Committee. Gavin D Perkins is a member of the NIHR Health Services and Delivery Research Researcher-led Panel and is a NIHR Senior Investigator. Claire Hulme is a member of the HTA Commissioning Board.

Published March 2017

DOI: 10.3310/hta21110

This report should be referenced as follows:

Gates S, Lall R, Quinn T, Deakin CD, Cooke MW, Horton J, *et al.* Prehospital randomised assessment of a mechanical compression device in out-of-hospital cardiac arrest (PARAMEDIC): a pragmatic, cluster randomised trial and economic evaluation. *Health Technol Assess* 2017;**21**(11).

Health Technology Assessment is indexed and abstracted in *Index Medicus/MEDLINE*, *Excerpta Medica/EMBASE*, *Science Citation Index Expanded (SciSearch®)* and *Current Contents®/Clinical Medicine*.

ISSN 1366-5278 (Print)

ISSN 2046-4924 (Online)

Impact factor: 4.058

Health Technology Assessment is indexed in MEDLINE, CINAHL, EMBASE, The Cochrane Library and the ISI Science Citation Index.

This journal is a member of and subscribes to the principles of the Committee on Publication Ethics (COPE) (www.publicationethics.org/).

Editorial contact: journals.library@nhr.ac.uk

The full HTA archive is freely available to view online at www.journalslibrary.nhr.ac.uk/hta. Print-on-demand copies can be purchased from the report pages of the NIHR Journals Library website: www.journalslibrary.nhr.ac.uk

Criteria for inclusion in the *Health Technology Assessment* journal

Reports are published in *Health Technology Assessment* (HTA) if (1) they have resulted from work for the HTA programme, and (2) they are of a sufficiently high scientific quality as assessed by the reviewers and editors.

Reviews in *Health Technology Assessment* are termed 'systematic' when the account of the search appraisal and synthesis methods (to minimise biases and random errors) would, in theory, permit the replication of the review by others.

HTA programme

The HTA programme, part of the National Institute for Health Research (NIHR), was set up in 1993. It produces high-quality research information on the effectiveness, costs and broader impact of health technologies for those who use, manage and provide care in the NHS. 'Health technologies' are broadly defined as all interventions used to promote health, prevent and treat disease, and improve rehabilitation and long-term care.

The journal is indexed in NHS Evidence via its abstracts included in MEDLINE and its Technology Assessment Reports inform National Institute for Health and Care Excellence (NICE) guidance. HTA research is also an important source of evidence for National Screening Committee (NSC) policy decisions.

For more information about the HTA programme please visit the website: <http://www.nets.nhr.ac.uk/programmes/hta>

This report

The research reported in this issue of the journal was funded by the HTA programme as project number 07/37/69. The contractual start date was in June 2009. The draft report began editorial review in July 2015 and was accepted for publication in May 2016. The authors have been wholly responsible for all data collection, analysis and interpretation, and for writing up their work. The HTA editors and publisher have tried to ensure the accuracy of the authors' report and would like to thank the reviewers for their constructive comments on the draft document. However, they do not accept liability for damages or losses arising from material published in this report.

This report presents independent research funded by the National Institute for Health Research (NIHR). The views and opinions expressed by authors in this publication are those of the authors and do not necessarily reflect those of the NHS, the NIHR, NETSCC, the HTA programme or the Department of Health. If there are verbatim quotations included in this publication the views and opinions expressed by the interviewees are those of the interviewees and do not necessarily reflect those of the authors, those of the NHS, the NIHR, NETSCC, the HTA programme or the Department of Health.

© Queen's Printer and Controller of HMSO 2017. This work was produced by Gates *et al.* under the terms of a commissioning contract issued by the Secretary of State for Health. This issue may be freely reproduced for the purposes of private research and study and extracts (or indeed, the full report) may be included in professional journals provided that suitable acknowledgement is made and the reproduction is not associated with any form of advertising. Applications for commercial reproduction should be addressed to: NIHR Journals Library, National Institute for Health Research, Evaluation, Trials and Studies Coordinating Centre, Alpha House, University of Southampton Science Park, Southampton SO16 7NS, UK.

Published by the NIHR Journals Library (www.journalslibrary.nhr.ac.uk), produced by Prepress Projects Ltd, Perth, Scotland (www.prepress-projects.co.uk).

Health Technology Assessment Editor-in-Chief

Professor Hywel Williams Director, HTA Programme, UK and Foundation Professor and Co-Director of the Centre of Evidence-Based Dermatology, University of Nottingham, UK

NIHR Journals Library Editor-in-Chief

Professor Tom Walley Director, NIHR Evaluation, Trials and Studies and Director of the EME Programme, UK

NIHR Journals Library Editors

Professor Ken Stein Chair of HTA Editorial Board and Professor of Public Health, University of Exeter Medical School, UK

Professor Andree Le May Chair of NIHR Journals Library Editorial Group (EME, HS&DR, PGfAR, PHR journals)

Dr Martin Ashton-Key Consultant in Public Health Medicine/Consultant Advisor, NETSCC, UK

Professor Matthias Beck Chair in Public Sector Management and Subject Leader (Management Group), Queen's University Management School, Queen's University Belfast, UK

Dr Tessa Crilly Director, Crystal Blue Consulting Ltd, UK

Dr Eugenia Cronin Senior Scientific Advisor, Wessex Institute, UK

Ms Tara Lamont Scientific Advisor, NETSCC, UK

Dr Catriona McDaid Senior Research Fellow, York Trials Unit, Department of Health Sciences, University of York, UK

Professor William McGuire Professor of Child Health, Hull York Medical School, University of York, UK

Professor Geoffrey Meads Professor of Health Sciences Research, Health and Wellbeing Research Group, University of Winchester, UK

Professor John Norrie Chair in Medical Statistics, University of Edinburgh, UK

Professor John Powell Consultant Clinical Adviser, National Institute for Health and Care Excellence (NICE), UK

Professor James Raftery Professor of Health Technology Assessment, Wessex Institute, Faculty of Medicine, University of Southampton, UK

Dr Rob Riemsma Reviews Manager, Kleijnen Systematic Reviews Ltd, UK

Professor Helen Roberts Professor of Child Health Research, UCL Institute of Child Health, UK

Professor Jonathan Ross Professor of Sexual Health and HIV, University Hospital Birmingham, UK

Professor Helen Snooks Professor of Health Services Research, Institute of Life Science, College of Medicine, Swansea University, UK

Professor Jim Thornton Professor of Obstetrics and Gynaecology, Faculty of Medicine and Health Sciences, University of Nottingham, UK

Professor Martin Underwood Director, Warwick Clinical Trials Unit, Warwick Medical School, University of Warwick, UK

Please visit the website for a list of members of the NIHR Journals Library Board:
www.journalslibrary.nihr.ac.uk/about/editors

Editorial contact: journals.library@nihr.ac.uk

Abstract

Prehospital randomised assessment of a mechanical compression device in out-of-hospital cardiac arrest (PARAMEDIC): a pragmatic, cluster randomised trial and economic evaluation

Simon Gates,^{1*} Ranjit Lall,¹ Tom Quinn,² Charles D Deakin,³ Matthew W Cooke,^{1,4} Jessica Horton,¹ Sarah E Lamb,^{1,5} Anne-Marie Slowther,¹ Malcolm Woollard,² Andy Carson,⁶ Mike Smyth,^{1,6} Kate Wilson,⁶ Garry Parcell,⁶ Andrew Rosser,⁶ Richard Whitfield,⁷ Amanda Williams,⁷ Rebecca Jones,⁷ Helen Pocock,³ Nicola Brock,³ John JM Black,³ John Wright,^{8,9} Kyee Han,⁸ Gary Shaw,⁸ Laura Blair,⁸ Joachim Marti,¹⁰ Claire Hulme,¹⁰ Christopher McCabe,¹¹ Silviya Nikolova,¹⁰ Zenia Ferreira¹⁰ and Gavin D Perkins^{1,4}

¹Warwick Clinical Trials Unit, University of Warwick, Coventry, UK

²Surrey Peri-operative Anaesthesia Critical Care Collaborative Research Group, Faculty of Health and Medical Sciences, University of Surrey, Guildford, UK (current address: Faculty of Health, Social Care and Education, Kingston University London and St George's, University of London, London, UK)

³South Central Ambulance Service NHS Foundation Trust, Otterbourne, UK

⁴Heart of England NHS Foundation Trust, Birmingham, UK

⁵Oxford Clinical Trials Research Unit, University of Oxford, Oxford, UK

⁶West Midlands Ambulance Service NHS Foundation Trust, Brierley Hill, UK

⁷Welsh Ambulance Services NHS Trust, St Asaph, UK

⁸North East Ambulance Service NHS Foundation Trust, Newcastle upon Tyne, UK

⁹Royal Victoria Infirmary, Newcastle upon Tyne, UK

¹⁰Academic Unit of Health Economics, Leeds Institute of Health Sciences, University of Leeds, Leeds, UK

¹¹Department of Emergency Medicine Research, University of Alberta, Edmonton, AB, Canada

*Corresponding author s.gates@warwick.ac.uk

Background: Mechanical chest compression devices may help to maintain high-quality cardiopulmonary resuscitation (CPR), but little evidence exists for their effectiveness. We evaluated whether or not the introduction of Lund University Cardiopulmonary Assistance System-2 (LUCAS-2; Jolife AB, Lund, Sweden) mechanical CPR into front-line emergency response vehicles would improve survival from out-of-hospital cardiac arrest (OHCA).

Objective: Evaluation of the LUCAS-2 device as a routine ambulance service treatment for OHCA.

Design: Pragmatic, cluster randomised trial including adults with non-traumatic OHCA. Ambulance dispatch staff and those collecting the primary outcome were blind to treatment allocation. Blinding of the ambulance

staff who delivered the interventions and reported initial response to treatment was not possible. We also conducted a health economic evaluation and a systematic review of all trials of out-of-hospital mechanical chest compression.

Setting: Four UK ambulance services (West Midlands, North East England, Wales and South Central), comprising 91 urban and semiurban ambulance stations. Clusters were ambulance service vehicles, which were randomly assigned (approximately 1 : 2) to the LUCAS-2 device or manual CPR.

Participants: Patients were included if they were in cardiac arrest in the out-of-hospital environment. Exclusions were patients with cardiac arrest as a result of trauma, with known or clinically apparent pregnancy, or aged < 18 years.

Interventions: Patients received LUCAS-2 mechanical chest compression or manual chest compressions according to the first trial vehicle to arrive on scene.

Main outcome measures: Survival at 30 days following cardiac arrest; survival without significant neurological impairment [Cerebral Performance Category (CPC) score of 1 or 2].

Results: We enrolled 4471 eligible patients (1652 assigned to the LUCAS-2 device and 2819 assigned to control) between 15 April 2010 and 10 June 2013. A total of 985 (60%) patients in the LUCAS-2 group received mechanical chest compression and 11 (< 1%) patients in the control group received LUCAS-2. In the intention-to-treat analysis, 30-day survival was similar in the LUCAS-2 (104/1652, 6.3%) and manual CPR groups [193/2819, 6.8%; adjusted odds ratio (OR) 0.86, 95% confidence interval (CI) 0.64 to 1.15]. Survival with a CPC score of 1 or 2 may have been worse in the LUCAS-2 group (adjusted OR 0.72, 95% CI 0.52 to 0.99). No serious adverse events were noted. The systematic review found no evidence of a survival advantage if mechanical chest compression was used. The health economic analysis showed that LUCAS-2 was dominated by manual chest compression.

Limitations: There was substantial non-compliance in the LUCAS-2 arm. For 272 out of 1652 patients (16.5%), mechanical chest compression was not used for reasons that would not occur in clinical practice. We addressed this issue by using complier average causal effect analyses. We attempted to measure CPR quality during the resuscitation attempts of trial participants, but were unable to do so.

Conclusions: There was no evidence of improvement in 30-day survival with LUCAS-2 compared with manual compressions. Our systematic review of recent randomised trials did not suggest that survival or survival without significant disability may be improved by the use of mechanical chest compression.

Future work: The use of mechanical chest compression for in-hospital cardiac arrest, and in specific circumstances (e.g. transport), has not yet been evaluated.

Trial registration: Current Controlled Trials ISRCTN08233942.

Funding: This project was funded by the National Institute for Health Research (NIHR) Health Technology Assessment programme and will be published in full in *Health Technology Assessment*; Vol. 21, No. 11. See the NIHR Journals Library website for further project information.

Contents

List of tables	xiii
List of figures	xv
List of boxes	xvii
List of abbreviations	xix
Plain English summary	xxi
Scientific summary	xxiii
Chapter 1 Introduction	1
Description of condition	1
<i>Definition</i>	1
<i>Chain of Survival</i>	1
<i>Early access</i>	1
<i>High-quality cardiopulmonary resuscitation</i>	1
<i>Early defibrillation</i>	2
<i>Post-resuscitation care</i>	2
<i>Incidence and burden of disease</i>	3
<i>Existing evidence</i>	3
<i>Rationale for intervention</i>	4
Chapter 2 Trial design and methods	5
Trial design	5
Objectives	5
<i>Primary objective</i>	5
<i>Secondary objectives</i>	5
<i>Selection of trial sites</i>	5
Outcome measures	5
<i>Primary outcome</i>	5
<i>Secondary outcomes</i>	5
Inclusion/exclusion criteria	6
<i>Eligibility for clusters</i>	6
<i>Eligibility for individual patients</i>	7
Randomisation	7
Treatment allocation	9
Consent	10
<i>Ethical considerations</i>	10
<i>Approaching survivors</i>	10
Protection against bias	11
<i>Cluster design</i>	11
<i>Threshold for resuscitation</i>	11
Monitoring device usage	12
Monitoring quality of cardiopulmonary resuscitation	12
Blinding	13
Training	13

Clinical management of patients in the trial	13
<i>Intervention arm</i>	14
<i>Manual chest compression arm</i>	14
Serious adverse event reporting	14
<i>Definitions</i>	14
<i>Additional terms for device trials</i>	15
<i>Events that should be reported</i>	15
<i>Reporting serious adverse events</i>	15
Data collection	16
<i>Identification of cardiac arrests</i>	16
<i>Deaths</i>	16
<i>Data management</i>	17
Statistical methods	17
<i>Power and sample size</i>	17
<i>Statistical analysis</i>	19
Approvals, registration and governance	20
Staffing	20
Protocol amendments	20
Chapter 3 Trial results	25
Overview of recruitment	25
<i>Recruitment of clusters</i>	25
<i>Recruitment of patients</i>	26
<i>Treatment</i>	29
<i>Follow-up</i>	31
<i>Outcomes: intention-to-treat analysis</i>	33
<i>Complier average causal effect analyses</i>	34
<i>Subgroup analyses</i>	34
<i>Serious adverse events</i>	36
<i>Follow-up at 3 months and 12 months</i>	36
Chapter 4 Mechanical chest compression for out-of-hospital cardiac arrest: systematic review and meta-analysis	39
Introduction	39
Methods	39
Results	42
Discussion	46
Chapter 5 Economic evaluation	47
Introduction	47
Methods	47
<i>Within-trial analysis</i>	47
<i>Quality-adjusted life-years</i>	47
<i>Resource use and costs</i>	47
<i>Missing data</i>	48
<i>Cost-effectiveness analysis</i>	48
<i>Uncertainty and sensitivity analysis</i>	50
<i>Long-term decision-analytic model</i>	51
<i>Cost-effectiveness analysis</i>	52
<i>Uncertainty and sensitivity analysis</i>	53
Results	53
<i>One-year costs</i>	53
<i>Quality of life</i>	53

<i>Cost-effectiveness at 1 year</i>	55
<i>Net monetary benefits</i>	56
<i>Long-term cost-effectiveness (Markov model)</i>	56
Chapter 6 Discussion	59
Summary of main results	59
Strengths and limitations	59
Other evidence	60
Chapter 7 Conclusions	63
Recommendations for research	63
Acknowledgements	65
References	69
Appendix 1 In-hospital data fields	77
Appendix 2 Training documents	83
Appendix 3 Event reporting	87
Appendix 4 Case report forms	89
Appendix 5 Three-month follow-up questionnaires	91
Appendix 6 Twelve-month follow-up questionnaires	107
Appendix 7 Data management plan	125
Appendix 8 Statistical analysis plan	141
Appendix 9 Systematic review search strategy	171
Appendix 10 End-of-study information sheet	173

List of tables

TABLE 1 Number of clusters required for 80% power to detect an increase in the incidence of survival to 30 days in the manual compression and LUCAS-2 groups	18
TABLE 2 Protocol amendments	22
TABLE 3 Number of vehicles randomised, by trial arm, in each locality	25
TABLE 4 Number of recruits by region and type of vehicle	28
TABLE 5 Baseline characteristics	29
TABLE 6 Treatment of cardiac arrest	31
TABLE 7 Number of patients included and not included in 3- and 12-month follow-up	32
TABLE 8 Baseline characteristics for all those patients with 3-month data ($N = 146$)	32
TABLE 9 Outcomes: adjusted ORs are adjusted for age, sex, response time, bystander CPR and initial rhythm	34
TABLE 10 Results of CACE analysis	35
TABLE 11 Subgroup analyses for primary outcome (30-day survival)	35
TABLE 12 Outcome at 3 months for SF-12 and EQ-5D: higher scores indicate better outcomes	36
TABLE 13 Outcomes at 12 months. For SF-12, EQ-5D and MMSE higher scores indicate better outcomes. For PCL-C and HADS, lower scores indicate better outcomes	37
TABLE 14 Results of quality of CPR manikin study	38
TABLE 15 Characteristics of studies and risk-of-bias assessments	40
TABLE 16 Summary table of ICU length-of-stay data	48
TABLE 17 Unit costs used in the analysis	49
TABLE 18 Cost of the LUCAS-2 device	50
TABLE 19 Model parameters	52
TABLE 20 Completion rate of HRQL and resource questionnaires	53
TABLE 21 One-year costs	54

TABLE 22 Health-related quality of life by treatment arm	55
TABLE 23 Incremental cost-effectiveness ratios	55
TABLE 24 Incremental cost-effectiveness ratios from lifetime analysis	57

List of figures

FIGURE 1 The Chain of Survival	1
FIGURE 2 Forest plot from Gates <i>et al.</i> 's systematic review of studies examining the LUCAS-2 device	4
FIGURE 3 Staff organogram	21
FIGURE 4 The Consolidated Standards of Reporting Trials (CONSORT) diagram for vehicles	26
FIGURE 5 Number of vehicles attending different numbers of cardiac arrests	27
FIGURE 6 Patient flow chart	28
FIGURE 7 Cumulative recruitment: April 2010 to June 2013	30
FIGURE 8 Flow chart of studies	42
FIGURE 9 Return of spontaneous circulation	44
FIGURE 10 Survived event (i.e. sustained ROSC to handover to hospital emergency department)	44
FIGURE 11 Survival to discharge from hospital or 30 days	45
FIGURE 12 Survival with CPC score of 1–2 or mRS score of 0–3	45
FIGURE 13 Structure of the decision-analytic model	51
FIGURE 14 Cost-effectiveness plane for the LUCAS-2 device compared with manual chest compression	56
FIGURE 15 Cost-effectiveness plane for the LUCAS-2 device compared with manual chest compression	57
FIGURE 16 Cost-effectiveness acceptability curves for the LUCAS-2 device compared with manual CPR	58

List of boxes

BOX 1 The ROLE criteria

8

List of abbreviations

A&E	accident and emergency	LUCAS-2	Lund University Cardiopulmonary Assistance System-2
ADE	adverse device effect/event	MHRA	Medicines and Healthcare products Regulatory Agency
AE	adverse event	MI	multiple imputation
ALS	advanced life support	MMSE	Mini Mental State Examination
ASPIRE	AutoPulse Assisted Prehospital International Resuscitation	MRIS	Medical Research Information Service
AUC	area under the curve	mRS	modified Rankin Scale
CACE	complier average causal effect	NICE	National Institute for Health and Care Excellence
CE	Conformité Européenne	NIHR	National Institute for Health Research
CEAC	cost-effectiveness acceptability curve	NMB	net monetary benefit
CI	confidence interval	OHCA	out-of-hospital cardiac arrest
CIRC	Circulation Improving Resuscitation Care	ONS	Office for National Statistics
CPC	Cerebral Performance Category	OR	odds ratio
CPR	cardiopulmonary resuscitation	PARAMEDIC	prehospital randomised assessment of a mechanical compression device in out-of-hospital cardiac arrest
CRF	case report form	PCL-C	Post-Traumatic Stress Disorder Civilian Checklist
DMC	Data Monitoring Committee	PEA	pulseless electrical activity
ECG	electrocardiography	PRF	patient report form
EMS	emergency medical services	PSS	Personal Social Services
EQ-5D	EuroQol-5 Dimensions	PTSD	post-traumatic stress disorder
GP	general practitioner	QALY	quality-adjusted life-year
HADS	Hospital Anxiety and Depression Scale	RCT	randomised controlled trial
HES	Hospital Episode Statistics	REC	Research Ethics Committee
HRQL	health-related quality of life	ROLE	Recognition of Life Extinction
ICC	intracluster correlation coefficient	ROSC	return of spontaneous circulation
ICER	incremental cost-effectiveness ratio	RR	risk ratio
ICNARC	Intensive Care National Audit and Research Centre	RRV	rapid response vehicle
ICU	intensive care unit	SADE	serious adverse device effect/event
ITT	intention to treat		
JRCALC	Joint Royal College Ambulance Liaison Committee		

LIST OF ABBREVIATIONS

SAE	serious adverse event	VF	ventricular fibrillation
SD	standard deviation	VT	ventricular tachycardia
SF-12	Short Form questionnaire-12 items	WCTU	Warwick Clinical Trials Unit
TSC	Trial Steering Committee		

Plain English summary

The main treatment for people who suffer a cardiac arrest out of hospital is cardiopulmonary resuscitation (CPR), whereby blood circulation is maintained by repeatedly compressing the chest. Maintaining high-quality CPR is very difficult, as people performing it tire and become less effective. Mechanical devices may be more effective than people at providing chest compression, as they do not tire, ensure that every compression is of the required depth and frequency and can operate in difficult conditions, such as in a moving ambulance.

In this study, we evaluated a mechanical chest compression device called LUCAS-2 (Lund University Cardiopulmonary Assistance System-2; Jolife AB, Lund, Sweden); this was introduced into ambulance services in the UK several years ago, but it is not yet known whether or not it improves survival. Four UK ambulance services took part in the study.

Vehicles were randomly allocated to carry a LUCAS-2 device or no LUCAS-2 device. If the vehicle carried a LUCAS-2 device it was used to provide chest compressions for all cardiac arrests for which resuscitation was attempted. If there was no LUCAS-2 device, manual chest compression was used. A total of 418 vehicles were included in the study and 4471 cardiac arrest patients were recruited. We recorded how many patients survived to 30 days after their cardiac arrest and how many survived without significant disability.

We found that there was no clear advantage of using the LUCAS-2 device. Survival was not improved and slightly more survivors who were treated with the LUCAS-2 device had significant disability. An economic analysis of the costs and benefits found that using the LUCAS-2 device was not as cost-effective as standard cardiac arrest treatment.

Scientific summary

Background

Chest compression is one of the crucial components of cardiopulmonary resuscitation (CPR). However, it is known that it is difficult to maintain adequate depth and frequency of compressions, reducing the patient's chances of survival. Mechanical chest compression devices have been proposed as a potential solution, as they can provide compressions of standard depth and frequency indefinitely, do not tire and can be used in situations in which manual chest compression is difficult. In this trial we evaluated use of the LUCAS-2 device (Lund University Cardiopulmonary Assistance System-2; Jolife AB, Lund, Sweden), which was introduced into UK ambulance services several years ago without any evidence of effectiveness.

Objectives

1. To conduct a pragmatic, cluster randomised trial of the LUCAS-2 device compared with standard manual chest compression for patients experiencing an out-of-hospital cardiac arrest.
2. To conduct an economic evaluation to estimate the cost-effectiveness of the LUCAS-2 device.
3. To perform a systematic review to combine the results of the current trial with those of other recent trials of mechanical chest compression.

Methods

Study design

The design was a cluster randomised controlled trial (RCT), with ambulance service vehicles [ambulances and rapid response vehicles (RRVs)] as the units of randomisation. Four UK ambulance services took part. An economic evaluation was also conducted and we performed a systematic review to synthesise the results of this and other recent randomised trials of mechanical chest compression.

Outcomes

Primary

1. Survival to 30 days post cardiac arrest.

Secondary

1. Survived event (survival to hospital).
2. Survival to hospital discharge.
3. Survival to 3 and 12 months.
4. Health-related quality of life at 3 and 12 months [Short Form questionnaire-12 items (SF-12)].
5. Neurological outcome at discharge from hospital [as measured via the Cerebral Performance Category (CPC) scale with a score of 1 or 2 vs. 3–5].
6. Neurological outcome at 12 months (as measured via the Mini Mental State Examination).
7. Anxiety and depression at 12 months (as measured via the Hospital Anxiety and Depression Scale).
8. Post-traumatic stress at 12 months (as measured via the Post-Traumatic Stress Disorder Civilian Checklist).
9. Hospital length of stay.
10. Intensive care length of stay.

Inclusion criteria

Patients were included if they were in cardiac arrest, if they were out of hospital, if resuscitation was attempted and if they were attended by a trial vehicle. Exclusions were cardiac arrest due to trauma, patients with a known or clinically apparent pregnancy and patients known to be or apparently aged < 18 years.

Randomisation and treatment

Cardiac arrests were identified from routine ambulance service records. Patients were automatically included in the trial if they met the inclusion criteria.

Data collection

Data were collected by research paramedics from ambulance service records. Deaths were identified from ambulance services and routine UK NHS data via the Health and Social Care Information Centre. Surviving patients were contacted for consent for follow-up and, if consent was given, they were visited at 3 and 12 months post cardiac arrest.

Analysis

We performed an intention-to-treat (ITT) analysis and, because of lower-than-expected compliance in the LUCAS-2 arm, complier average causal effect (CACE) analyses. For the CACE analyses, we classified cases of non-compliance into those that would happen in normal clinical practice (e.g. device malfunction, location too restricted to use the LUCAS-2 device) and those that were specific to the context of the trial.

Economic evaluation

The economic evaluation assessed the cost-effectiveness of use of the LUCAS-2 device. It consisted of two complementary sets of analyses: a within-trial analysis over the 12-month trial period and a decision-analytic model that was constructed to extrapolate the results over the expected lifetime of the trial participants. The cost-effectiveness analyses were conducted from the NHS and Personal Social Services perspective. The analyses report cost per incremental quality-adjusted life-year of LUCAS-2 compared with usual care (manual chest compression). Data from various sources were combined to estimate costs and treatment benefits, including trial case report forms, large data sets (i.e. Hospital Episode Statistics, Intensive Care National Audit and Research Centre data), self-completed patient questionnaires and data extracted from the literature.

Systematic review

We searched for randomised trials evaluating mechanical chest compression (using any device) published since 1990 (search date February 2015). Data were extracted by two authors and meta-analyses conducted using Review Manager software version 5.3 (RevMan, The Cochrane Collaboration, The Nordic Cochrane Centre, Copenhagen, Denmark). Outcomes were return of spontaneous circulation, survival of event, survival to discharge from hospital or 30 days and survival with good neurological outcome (measured by CPC or modified Rankin Scale).

Results

We enrolled 4471 eligible patients (1652 assigned to the LUCAS-2 group and 2819 assigned to the control group) between 15 April 2010 and 10 June 2013. Nine hundred and eighty-five (60%) patients in the LUCAS-2 group received mechanical chest compression and 11 (< 1%) patients in the control group received LUCAS-2 treatment. In the ITT analysis, 30-day survival was similar in the LUCAS-2 [104 (6.3%) of 1652 patients] and manual CPR groups [193 (6.8%) of 2819 patients; adjusted odds ratio (OR) 0.86, 95% confidence interval (CI) 0.64 to 1.15]. Survival with a CPC score of 1 or 2 was worse in the LUCAS-2 group (adjusted OR 0.72, 95% CI 0.52 to 0.99). No serious adverse events were noted. The systematic review found no evidence that mechanical chest compression was superior to manual. The economic analysis consistently showed that treatment with the LUCAS-2 device was more costly and less effective than manual CPR, although differences in mean costs and outcomes between both treatment arms were fairly small.

These results were obtained both in the within-trial analysis and in the analysis that modelled lifetime costs and outcomes. When missing data were handled by multiple imputation, estimated costs were higher in both arms, but the incremental cost-effectiveness ratios also indicated that manual CPR dominates LUCAS-2.

Conclusions

The trial, systematic review and economic evaluation all found that there was no evidence that mechanical chest compression using LUCAS-2 was superior to standard manual chest compression.

Trial registration

This trial is registered as ISRCTN08233942.

Funding

Funding for this study was provided by the Health Technology Assessment programme of the National Institute for Health Research.

Chapter 1 Introduction

Description of condition

Definition

Cardiac arrest is defined as the cessation of cardiac mechanical activity, as confirmed by the absence of signs of circulation.¹ The majority of cardiac arrests outside a hospital occur as a result of cardiac causes (e.g. ischaemic heart disease, myocardial infarction, arrhythmia). Other causes of cardiac arrest include trauma, submersion, drug overdose, asphyxia, exsanguination or other medical causes (e.g. stroke, pulmonary embolus).^{1,2}

There are three different mechanisms through which cardiac arrest occurs – the development of an arrhythmia that leads to loss of cardiac output [ventricular fibrillation (VF) or ventricular tachycardia (VT)], insufficient cardiac contraction to generate a cardiac output, pulseless electrical activity (PEA) and a failure of the electrical conduction system of the heart (asystole).³

The manifestations of cardiac arrest are dramatic: within seconds of it occurring the blood supply to the brain and vital organs ceases. The victim loses consciousness and the process of cell death commences. There is a narrow window of opportunity (minutes) during which, if the heart can be restarted, the victim may be successfully resuscitated. The longer the victim remains in cardiac arrest, the worse the outcome and if attempts at restarting the heart are either delayed or unsuccessful then death will occur.

Chain of Survival

The Chain of Survival (Figure 1) describes a series of steps that need to be in place to optimise the chances of survival from out-of-hospital cardiac arrest (OHCA).⁴

Early access

The first link in the chain is early access, which highlights the importance of identifying a patient at risk of cardiac arrest (e.g. someone suffering from an acute myocardial infarction) or someone who has sustained a cardiac arrest (identified by the loss of consciousness and absence of normal breathing) and getting a trained advanced life support (ALS) team to them as rapidly as possible.

High-quality cardiopulmonary resuscitation

The second link in the Chain of Survival is early cardiopulmonary resuscitation (CPR). CPR is the combination of chest compressions and ventilations and is optimally started by those who are initially at the scene of the



FIGURE 1 The Chain of Survival. Reprinted from Jerry Nolan, Jasmeet Soar, Harald Eikeland. *The Chain of Survival. Resuscitation* (2006), 71;270–1 with permission from the Resuscitation Council (UK) and Laerdal Medical.

collapse. This is known as bystander CPR. Bystander CPR increases the odds of survival by 1.23 [95% confidence interval (CI) 0.71 to 2.11] in the studies with the highest baseline survival rates and by 5.01 (95% CI 2.57 to 9.78) in the studies with the lowest baseline rates.⁵ When the emergency services arrive on scene they will take over CPR. Current resuscitation guidelines highlight the importance of high-quality CPR for ensuring optimal outcomes from cardiac arrest.⁶ High-quality CPR is defined as CPR that ensures that an adequate chest compression depth is achieved (5–6 cm), the compression rate is 100–120 per minute, interruptions are minimised and the chest is allowed to recoil between chest compressions.

Evidence supporting the importance of high-quality CPR is observational: there are no randomised trials evaluating different compression parameters. Nevertheless, high-quality CPR appears to be important to outcomes.⁷ Experimental studies show a linear increase in cardiac output and coronary perfusion pressure with increasing compression depths.^{8,9} Observational studies in humans found improved shock success¹⁰ and better return of spontaneous circulation (ROSC) rates and long-term survival with deeper chest compressions.^{11,12} Faster chest compression rates (> 100 minutes) are associated with improved survival^{13–15} and ensuring that the chest is allowed to recoil between sequential chest compressions also appears to be important.¹⁶

Interruptions in CPR are harmful.¹⁷ A particularly critical time to minimise interruptions to CPR is around the time of attempted defibrillation. Prolonged pre-shock and peri-shock interruptions in CPR reduce the chances of shock success¹⁰ and survival.¹⁸

Early defibrillation

Approximately one-quarter of OHCA in the UK occurs as a result of an arrhythmia: either VF or VT. These rhythms are referred to as shockable rhythms, as the arrhythmias may be terminated and cardiac function restored by the successful delivery of defibrillator shocks. The time from the onset of VF/VT to the delivery of a shock is critical to shock success and chances of survival. For every 60–90 seconds that a shock is delayed, the chance of survival falls by approximately 10%.¹⁹

If a defibrillator is immediately available at the scene of a cardiac arrest, defibrillation should be attempted without delay. Where there is a delay in initiating CPR, there is a theoretical rationale that providing CPR before a shock improves coronary perfusion and thereby the chances of achieving sustained ROSC.²⁰ This concept was evaluated by the Resuscitation Outcomes Consortium in a cluster randomised trial that compared early analysis [30–60 seconds of emergency medical services (EMS)-administered CPR before initial rhythm analysis] with later analysis (180 seconds of CPR, before the initial electrocardiographic analysis).²¹ The primary outcome was survival to hospital discharge with satisfactory functional status [a modified Rankin Scale (mRS) score of ≤ 3 , on a scale of 0–6, with higher scores indicating greater disability]. The study²¹ enrolled 9933 patients (5290 to early analysis and 4643 to late analysis), but found no difference in outcomes (cluster-adjusted difference of -0.2% , 95% CI -1.1% to 0.7%).

Post hoc analyses found that for ambulance services with baseline VF survival of $< 20\%$, 'analyse late' compared with 'analyse early' was associated with a lower chance of favourable functional survival (3.8% vs. 5.5%; OR 0.67, 95% CI 0.50 to 0.90). Conversely, in ambulance services with VF survival of $> 20\%$, 'analyse late' was associated with a higher likelihood of favourable functional survival than 'analyse early' (7.5% vs. 6.1%; OR 1.22, 95% CI 0.98 to 1.52).²²

In the UK, the Joint Royal College Ambulance Liaison Committee (JRCALC) recommended that defibrillation should not be delayed to allow for a set period of predefibrillation CPR. In practical terms, this means that when an ambulance crew arrive at the scene of a cardiac arrest they will start CPR while the defibrillator/monitor is attached. Once attached, rhythm analysis and, if indicated, defibrillation should take place without further delay.

Post-resuscitation care

The return of a spontaneous circulation marks the start of the post-resuscitation care phase of treatment.²³ Unless the arrest has been relatively brief, most patients who achieve a ROSC will have an obtunded

consciousness level, necessitating admission to intensive care. The focus of the post-resuscitation care phase of treatment is upon stabilising cardiac function to prevent a further arrest and minimising the consequences of the cardiac arrest on neurological outcome. This involves the use of targeted temperature management, avoidance of hyperglycaemia and cardiac reperfusion treatments. Most post-resuscitation care treatments are initiated following arrival in the emergency department and in the intensive care unit (ICU).

Incidence and burden of disease

Data from NHS England indicate that UK NHS ambulance services attend approximately 60,000 cardiac arrests each year; of those arrests attended, resuscitation is attempted in just less than half (28,000 cases).²⁴ Approximately 25% achieve an initial ROSC. However, only approximately one-third of those who achieve a ROSC survive to go home from hospital; thus, the overall survival to discharge rate is approximately 8%. The burden of disease is high, with an estimated 460,000 potential years of life lost, 270,000 of which are working years of life lost.

Functional survival after cardiac arrest is generally good, with the majority of those surviving doing so with a favourable neurological outcome.²⁵ Survivors may experience post-arrest problems, including anxiety, depression, post-traumatic stress and difficulties with cognitive function.²⁶

Despite the annual death toll exceeding that of dementia, stroke or lung cancer, there has been relatively little investment in research into this lethal condition. This has created a relatively weak evidence base compared with other diseases (e.g. there are 50-fold more trials per 10,000 deaths from myocardial infarction than deaths from cardiac arrest). A review of the National Institute for Health Research (NIHR) cardiovascular portfolio identified only 4 of 624 studies related to cardiac arrest. Until recently, the pattern was similar in the USA.²⁷

Existing evidence

At the time of initiating the PARAMEDIC (prehospital randomised assessment of a mechanical compression device in OHCA) trial, there were no large published randomised controlled trials (RCTs) evaluating the LUCAS-2 (Lund University Cardiopulmonary Assistance System-2; Jolife AB, Lund, Sweden) device. A systematic review of the literature in 2012²⁸ identified 16 studies investigating the LUCAS-2 device. Four of the studies were animal studies and 12 were human studies. Of the 12 human studies, one was a RCT and 11 were observational studies using either a cohort or before-or-after design (*Figure 2*).

The main finding of this review was that the existing evidence about the use of the LUCAS device is inconclusive. The animal studies tended to provide evidence that the LUCAS-2 device improved physiological end points, although the results were not consistent across studies.

Studies involving humans similarly lack consistency in the direction of benefit compared with harm. We chose not to perform any meta-analyses because of observed heterogeneity, varying study design and the high risk of bias in most of the included studies.

We concluded that the evidence base is insufficient for making any recommendations about the routine use of the LUCAS-2 device in clinical practice.

This conclusion is similar to the International Liaison Committee for Resuscitation Consensus on Science and Treatment's recommendation,²⁰ which advised that:

... there are insufficient data to support or refute the use of LUCAS-2 CPR instead of manual CPR. It may be reasonable to consider LUCAS-2 CPR to maintain continuous chest compression while undergoing computed tomography (CT) scan or similar diagnostic studies, when provision of manual CPR would be difficult.

Deakin et al.²⁰

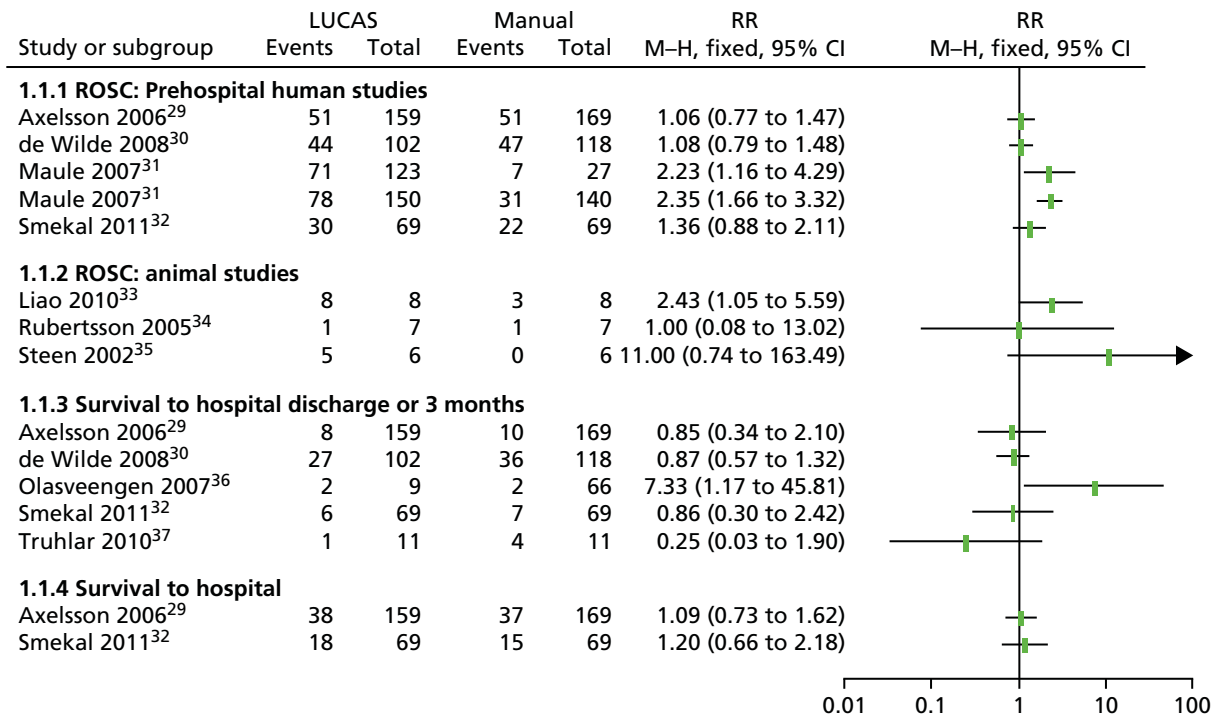

FIGURE 2 Forest plot from Gates *et al.*'s²⁸ systematic review of studies examining the LUCAS-2 device. M-H, Mantel-Haenszel; RR, risk ratio. Reproduced from *Heart*, Gates S, Smith JL, Ong GJ, Brace SJ, Perkins GD, 98, 908–13, 2012 with permission from *BMJ* Publishing Group Ltd.

Rationale for intervention

Because of the problems with manual chest compression, several mechanical devices have been proposed. These have potential advantages: they are able to provide compressions of a standard depth and frequency for long periods without interruption or fatigue and they free emergency medical personnel to attend to other tasks.

The LUCAS-2 is a mechanical device that provides automatic chest compressions. It delivers sternal compression at a constant rate, to a fixed depth, by a piston with the added feature of a suction cup that helps the chest return back to the normal position. It compresses 100 times per minute to a depth of 4–5 cm. It is easy to apply, stable in use, relatively light in weight (7.8 kg) and well adapted to use during patient movement on a stretcher and during ambulance transportation. The device is Conformité Européenne (CE) marked and has been on the market in Europe since 2002.

Detailed descriptions of the device and experimental data from animal studies showing increased cardiac output and cortical cerebral flow compared with manual standardised CPR have been published.^{35,38}

The LUCAS-2 device was introduced into a small number of ambulance services in the UK several years ago, despite the absence of evidence of its effectiveness from randomised trials.³⁹ It was subsequently withdrawn from routine use by several of the services because of lack of evidence about safety and efficacy and is now used only under restricted conditions. In the absence of evidence of clinical effectiveness or cost-effectiveness and the presence of some concerns regarding safety, the JRCALC, in discussion with the Department of Health, identified the need for large-scale clinical trials to evaluate the device.⁴⁰ Until such studies are completed, no further new purchases of the device are recommended by the JRCALC. A briefing note commissioned by the National Institute for Health and Care Excellence (NICE) concluded that 'there is therefore an urgent need to evaluate this technology to discover whether it is effective and cost-effective in improving survival after cardiac arrest'. The need for a definitive trial is reinforced in the International Liaison Committee for Resuscitation's analysis of knowledge gaps in resuscitation.⁴¹

Chapter 2 Trial design and methods

Trial design

The PARAMEDIC trial was a pragmatic, cluster randomised trial, with ambulance service vehicles as the unit of randomisation, comparing mechanical chest compression using the LUCAS-2 device with standard manual chest compression, for patients in OHCA. The trial protocol has been published elsewhere.⁴²

The trial was undertaken in partnership with four NHS ambulance services (West Midlands, North East England, Welsh Ambulance Service and South Central). These organisations serve a total population of 13 million, spread over 62,160 km². Vehicles were randomly allocated before the start of recruitment to carry the LUCAS-2 device (LUCAS-2 arm) or not (manual compression arm).

We chose to use a cluster randomised design because of costs and concerns that an individually randomised design would have a substantial risk of contamination among the manual compression arm. With individual randomisation, all vehicles taking part in the trial would have to carry a LUCAS-2 device and there would be a strong possibility that it would be used for patients who were allocated to manual compression, especially if the perception of paramedics was that the LUCAS-2 device made chest compression easier and allowed them to carry out other tasks more effectively.

Objectives

Primary objective

To evaluate the effect on mortality of using the LUCAS-2 device rather than manual chest compression during resuscitation by ambulance clinicians (paramedics, technicians, emergency care assistants, etc.) after OHCA at 30 days after the event.

Secondary objectives

To evaluate the effects of LUCAS-2 treatment on survival to 12 months, the cognitive and neurological outcomes of survivors and the cost-effectiveness of the LUCAS-2 device.

Selection of trial sites

The NHS organisations that delivered the trial were ambulance trusts. Initially (at the time of the funding application), we anticipated that three trusts would participate covering the West Midlands, Wales and Scotland. However, the Scottish Ambulance Service withdrew from the trial before the start of recruitment because its legal team was not happy with the research contract. The North East Ambulance Service and South Central Ambulance Service subsequently joined the trial.

Outcome measures

Primary outcome

Survival to 30 days post cardiac arrest.

Secondary outcomes

- Survived event (sustained ROSC, with spontaneous circulation until admission and transfer of care to medical staff at the receiving hospital).

- Survival to hospital discharge (the point at which the patient is discharged from the hospital acute care unit regardless of neurological status, outcome or destination).
- Survival to 3 and 12 months.
- Health-related quality of life (HRQL) at 3 and 12 months [Short Form questionnaire-12 items (SF-12)⁴³ and EuroQol-5 Dimensions (EQ-5D)].⁴⁴
- Neurologically intact survival to 3 months [survival with a Cerebral Performance Category (CPC)⁴⁵ score of 1 or 2].
- Cognitive outcome at 12 months [as measured via the Mini Mental State Examination (MMSE)].⁴⁶
- Anxiety and depression at 12 months [as measured via the Hospital Anxiety and Depression Scale (HADS)].⁴⁷
- Post-traumatic stress at 12 months [as measured via the post-traumatic stress disorder (PTSD) Civilian Checklist (PCL-C)].⁴⁸
- Hospital length of stay.
- Intensive care length of stay (see *Appendix 1*).

The outcomes defined by the Utstein convention¹ for reporting outcomes from cardiac arrest are reported, as well as long-term follow-up at 12 months. We did not measure the incidence of injuries resulting from CPR, for three reasons: first, they are of little importance unless they result in differences in more substantive outcomes such as survival or duration of hospitalisation; second, they are difficult to measure and classify and may not be detected reliably; and, third, organising injury data collection from a large number of hospitals was felt to add significant organisational complexity to the trial, for little benefit.

The CPC score is a 5-point scale for describing the neurological outcome after cardiac arrest and is recommended by the Utstein guidelines.¹ There is a generally accepted split into good neurological outcome (CPC score of 1 or 2) and poor outcome (CPC score of 3–5). The definitions of the categories are:

- *CPC 1* Good cerebral performance: conscious, alert, able to work.
- *CPC 2* Moderate cerebral disability: conscious, sufficient cerebral function for independent activities of daily life. Able to work in sheltered environment.
- *CPC 3* Severe cerebral disability: conscious, dependent on others for daily support because of impaired brain function. Ranges from ambulatory state to severe dementia or paralysis.
- *CPC 4* Coma or vegetative state: any degree of coma without the presence of all of the brain death criteria.
- *CPC 5* Brain death.

However, recent studies have demonstrated that this score may be insensitive to some of the more subtle, but nevertheless important, longer-term neurocognitive and functional impairments that are experienced by survivors of cardiac arrest.^{49,50} The spectrum of impairment of HRQL following cardiac arrest includes memory and cognitive dysfunction, affective disorders and PTSD.⁴⁸ The number of patients who are expected to survive to hospital discharge was anticipated to be in the region of 200–300, which allowed more intensive follow-up. We used four clinical outcome measures: the SF-12 is a standard quality-of-life measure that is short and easy to complete. The PTSD PCL-C⁴⁸ is a 17-item questionnaire measuring the risk of developing PTSD and has been used in previous studies as a good surrogate for the clinical diagnosis of PTSD, which would require a face-to-face interview by a suitably trained professional. The HADS⁴⁷ is a 14-item self-administered questionnaire, which has been previously used successfully to measure affective disorders in those surviving cardiac arrest.⁵¹ The MMSE measures cognitive impairment.⁵² In addition, the EQ-5D⁴⁴ was used as a health utility measure for the health economic analysis.

Inclusion/exclusion criteria

Eligibility for clusters

All vehicles that were in service at each participating ambulance station, eligible to attend patients and could carry the device were included in the trial and randomised to one of the trial arms before the start of recruitment.

To maximise the efficiency of the trial, recruitment was concentrated predominantly in urban areas, where each vehicle would attend a higher number of cardiac arrests per year. This avoided the costs of supporting clusters in rural areas that were able to recruit very few patients, increased the size of clusters and increased the survival rate for the trial population by omitting patients who could not be reached quickly and had a very low chance of survival. These considerations should all have helped to improve power to detect a difference between the LUCAS-2 device and manual compression arms in the trial.

Eligibility for individual patients

Patients were eligible if they met all four of the criteria below:

1. Cardiac arrest in the out-of-hospital environment.
2. First ambulance resource was a trial vehicle.
3. Resuscitation attempt was initiated by the attending ambulance clinicians, in accordance with JRCALC guidelines.⁵³
4. The patient was known, or believed to be, aged ≥ 18 years.

The exclusion criteria were:

- cardiac arrest caused by trauma
- known or clinically apparent pregnancy.

All patients who fulfilled the eligibility criteria were included in the trial. The JRCALC Recognition of Life Extinction (ROLE) guidelines⁵³ were applied to determine patients for whom a resuscitation attempt was inappropriate. This is the case when there is no chance of survival; when the resuscitation attempt would be futile and distressing for relatives, friends and health-care personnel; and when time and resources would be wasted undertaking such measures. If there was clear evidence that life was extinct (*Box 1*) or if the patient had a 'do not attempt resuscitation' order, ambulance staff were authorised to recognise death and withhold CPR.

The LUCAS-2 device cannot be used if patients are too large or too small: the device fits patients with a sternum height of 17.0–30.3 cm and a chest width of < 45 cm. However, patient size was not an exclusion criterion because it would be impossible to apply correctly to the manual compression group, hence potentially introducing bias. Moreover, it was appropriate to include the small proportion of patients who were too large or too small for the LUCAS-2 device in the trial, in accordance with intention-to-treat (ITT) principles. The trial estimated the impact of the LUCAS-2 device on the survival rate among the whole cardiac arrest population. In one Swedish study,²⁹ only 3 out of 159 patients (1.9%) were found to be too small or too large for the LUCAS device. We therefore anticipated that there would be only a small number of patients for whom the LUCAS-2 device could not be used, especially as the LUCAS-2 device accommodates larger patients than the LUCAS version 1 device that was used in the Swedish study.

Randomisation

Randomisation of trial vehicles to the LUCAS-2 and control arms was performed by the study statisticians before the devices were supplied to participating stations. As the number of LUCAS-2 devices was limited, it was inefficient to randomise vehicles in a 1 : 1 ratio. This would have entailed some vehicles at each station not contributing to the trial and, hence, non-inclusion of potentially eligible cardiac arrest patients. It would also be operationally more difficult for ambulance service staff, as procedures would be different between trial and non-trial vehicles. Because there was little cost associated with including additional standard care clusters, we included all eligible vehicles at each station in the trial, with the majority allocated to the control arm and a random selection (stratified by type of vehicle) allocated to the LUCAS-2 arm. This ensured that all

BOX 1 The ROLE criteria

Massive cranial and cerebral destruction.

Hemicorpectomy.

Massive truncal injury incompatible with life (including decapitation).

Decomposition/putrefaction.

Incineration.

Hypostasis.

Rigor mortis.

A valid 'do not attempt resuscitation' order or an advanced directive (living will) that states the wish of the patient not to undergo attempted resuscitation.

When the patient's death is expected as a result of terminal illness.

Efforts would be futile, as defined by the combination of all three of the following being present:

1. more than 15 minutes since the onset of collapse.
2. no bystander CPR prior to arrival of the ambulance.
3. asystole (flat line) for > 30 seconds on the ECG monitor screen.

Exceptions are:

1. drowning
2. drug overdose/poisoning
3. trauma
4. submersion of adults for longer than 1 hour.

ECG, electrocardiography.

eligible cardiac arrests were included in the trial. The number of LUCAS-2 devices allocated to each station was determined by the number of vehicles. In all of the stations, at least one device was allocated to a rapid response vehicle (RRV) and one to an ambulance (unless there were no vehicles of a type at a station). The number of vehicles available varied and it was not possible to ensure that allocation was in any precise ratio, but we aimed for the ratio of LUCAS-2 to standard care vehicles to be approximately 1 : 2. If new vehicles were brought into service at participating stations during the recruitment period, these were also randomised.

The randomisation sequence was computer generated, with stratification by station and type of vehicle. Once randomised, a vehicle's allocation could not be changed and it remained in that group throughout the trial. Clusters were terminated if a vehicle left the trial permanently (e.g. was scrapped or withdrawn from front-line service).

Early in the trial it became apparent that ambulances and RRVs frequently moved between stations, and it was not possible to identify a set of vehicles that would be consistently present at a participating station. Hence, many of the vehicles initially randomised at a station moved elsewhere and were replaced by vehicles that had not been randomised. This resulted in a low proportion of potentially eligible cardiac arrests being attended by trial vehicles. We therefore tried as far as possible to randomise stations that were geographically close, so that most transfers of vehicles between stations would be to another station that was participating in the trial. This reduced the proportion of cardiac arrests that were attended by non-trial vehicles.

A slightly different method of randomisation was used by the North East Ambulance Service. This region used a different system of allocation of vehicles, in which vehicles did not have a base station, but were based at two main depots. From here, vehicles were allocated to stations as needed. This meant that there was a major problem with vehicle rotations; vehicles rarely stayed at the same station for a prolonged period, and there were no geographically close sets of stations around which vehicles tended to rotate. Because it was possible (for logistical reasons) to include only a limited number of stations in this region in the trial, the investigators and Trial Steering Committee (TSC) felt that it was appropriate to use a different system of randomisation for this region. This was intended to be equivalent to the usual system of randomisation by vehicle. The North East Ambulance Service randomisation system used 'virtual vehicles'; at each station, each vehicle place was randomised to the LUCAS-2 or control arm, with stratification by type of vehicle. So, for example, if there were three ambulances at a station, number two might be randomised to the LUCAS-2 arm, so whichever ambulance filled that position on a particular day would carry the LUCAS-2 device and recruit patients to the LUCAS-2 arm. The disadvantage of this system was that the LUCAS-2 devices did not stay with the same vehicle, but had to be loaded on to the correct vehicle at the beginning of each shift and removed afterwards. However, the crews had done this for a previous trial, so were used to the process, and no problems of missing LUCAS-2 devices were encountered. This system ensured that cardiac arrests attended by ambulances from participating stations would be recruited to the trial. If we had used the same system in the North East Ambulance Service as elsewhere, then the recruitment rate would have been much lower.

Treatment allocation

A dispatch centre in each region co-ordinated the emergency response. The nearest available RRV or ambulance was dispatched to cases of suspected cardiac arrest. Back-up was provided by a second vehicle as soon as possible.

Treatment allocation of each individual participant was determined by the first trial vehicle to arrive on scene. If this was a LUCAS-2 device-containing vehicle, the patient was assigned to the LUCAS-2 arm, and if it was a non-LUCAS-2 device-containing vehicle (control), the patient was allocated to the manual compression arm. If the trial vehicle was not the first ambulance service vehicle to arrive on scene – that is, a double-manned ambulance or a single-manned RRV that was not part of the trial had already arrived and commenced resuscitation – the patient was not included in the trial. If the first response on scene was a community responder (volunteer members of the public trained in basic life support and defibrillation, despatched by ambulance control) or other responses (such as motorbike, helicopter or unmarked car) then the patient was included and their allocation was determined by the first trial vehicle to arrive, providing that continued resuscitation was indicated.

We aimed to include all eligible patients who were attended by a participating vehicle during the trial recruitment period. The attending ambulance clinicians determined whether or not a resuscitation attempt was appropriate, according to the JRCALC guidelines.⁵³ Patients were regarded as participating in the trial when a resuscitation attempt was initiated by the attending ambulance service personnel.

Consent

Ethical considerations

The occurrence of a cardiac arrest out of hospital is unpredictable. Within seconds of cardiac arrest, a person becomes unconscious and thus incapacitated. It was not therefore possible to obtain prospective consent directly from the research participant.

Treatment (in the form of CPR) must be started immediately in an attempt to save the person's life. In this setting it was not practical to consult a carer or independent registered medical practitioner without placing the potential participant at risk of harm from delaying treatment.

Conducting research in emergency situations in which a patient lacks capacity is regulated by the Mental Capacity Act (2005)⁵⁴ for England and Wales. The PARAMEDIC trial was approved in accordance with these requirements by the Coventry Research Ethics Committee (REC) (reference number 09/H1210/69). Ethics approval was also gained from the Scotland A REC, but the Scottish Ambulance Service subsequently withdrew from the study.

Approaching survivors

The nature of the condition meant that the majority (85–90%) of people in the study would not survive. Of those patients admitted to hospital alive, the majority (approximately 80%) would be comatose and admitted to an ICU (and thus remain incapacitated). Following admission to intensive care, approximately half of the people who initially survive die without regaining capacity (on average within 48 hours). The average duration of hospital stay for survivors is 18 days.⁵⁵

To avoid unnecessary distress to the relatives of the deceased, the timing of the approach was important and had to balance the need to inform at an early opportunity while determining – as accurately as possible – which patients had died. Pilot work for this trial established that it is not possible for ambulance services to determine with sufficient accuracy which patients have died, so the procedure was revised, based on the procedures of the ICON (Intensive Care Outcome Network) study.⁵⁶

The participating ambulance services conducted their own checks on patients' survival using existing data systems, which differed between services. Where possible, ambulance services consulted the NHS Patient Demographics Service. Other checks carried out by either the ambulance service and/or the Warwick Clinical Trials Unit (WCTU), included contacts with hospitals, general practitioners (GPs), the Intensive Care National Audit and Research Centre (ICNARC) and local registrars of births and deaths (see *Identification of cardiac arrests*).

If a patient was transported to hospital, his/her clinical and contact details were sent to the study co-ordinating centre at the WCTU. Staff at the co-ordinating centre checked the status of each potential survivor with the Medical Research Information Service (MRIS) approximately 6 weeks after the patient's cardiac arrest. This timing of the approach was selected to ensure that the majority of deaths had been included in the MRIS database. All of the survivors were flagged on the MRIS database and the trial co-ordinating centre was informed of any subsequent deaths.

After these checks, if someone was still believed to be alive then the co-ordinating centre contacted the person at his/her home address by letter to provide information about the study and the follow-up. If there was no response after 2 weeks, then the co-ordinating centre tried to contact the patient by telephone (if the telephone number was known) or by letter. If the patient wished to take part in the follow-up, then they could contact the WCTU by using the reply slip, telephone or e-mail. This gave the participants an opportunity to discuss the study and, if they were happy to proceed, a 3-month follow-up appointment was made. The consent form was either returned by post or signed at the 3-month follow-up visit. Patients who did not respond were approached again at 10 months post cardiac arrest in an attempt to invite them to participate in a 12-month visit.

In the event that the co-ordinating centre was notified (or had reason to believe) that a patient lacked capacity, an approach was made to his/her GP in order to establish if the patient had capacity to consent. In the event that a patient lacked capacity to consent, we sought the views of a personal consultee in order to establish the patient's wishes. If a personal consultee could not be identified, a carer (unconnected with the study) determined if the patient would be likely to consent to follow-up.

Protection against bias

Cluster design

One of the major potential sources of bias in cluster randomised trials is selection bias, which can arise if different patients are selected for inclusion in the two trial arms. This can arise when clinicians or people selecting patients are aware of the allocation of the cluster and they may consciously or unconsciously apply inclusion criteria differently depending on the randomised intervention. There is greater scope for selection bias if a large proportion of potentially eligible patients are not included in the trial. In this trial, paramedics assessing patients for inclusion were aware of the allocations; however, we aimed to identify and include close to 100% of the eligible patients, using a combination of methods for identifying eligible patients (see *Eligibility for individual patients*). This should avoid most selection bias.

Threshold for resuscitation

As the ambulance clinicians who were delivering the interventions were not blinded, there was a possibility that bias could be introduced by different thresholds for resuscitation between the LUCAS-2 and standard care arms: if they believed strongly that the LUCAS-2 device was effective, some of them might have attempted resuscitation in the LUCAS-2 arm on patients who had no chance of survival, and for whom a resuscitation attempt was therefore inappropriate. This would have resulted in a group of patients with a very low probability of survival being recruited to the LUCAS-2 arm but not to the standard care arm, potentially masking any beneficial effect of the LUCAS-2 device. We used several strategies to prevent this bias from occurring, to detect if it was to happen and to correct it if necessary.

First, the criteria that were used to determine whether or not a resuscitation attempt was appropriate, and hence whether or not the patient was eligible, were as objective as possible. The JRCALC ROLE criteria⁵³ were used by all of the participating ambulance services to determine when a resuscitation attempt is inappropriate, and this continued in the trial (see *Eligibility for individual patients*). Ambulance clinicians were therefore familiar with the application of these criteria and no change of practice was needed during the trial. However, there remained scope for differential application of the criteria to the two trial arms, so further strategies were devised.

Second, all ambulance clinicians in the trial were trained in the trial procedures⁵⁷ to ensure that they understood the rationale for the trial and the importance of following the trial procedures. The training included a review of existing evidence so that participating ambulance clinicians understood the current position of equipoise regarding the effectiveness of the LUCAS-2 device and discussion of potential sources of bias in the trial and the importance of applying the inclusion/exclusion criteria rigorously to both arms. Training continued throughout the recruitment period to ensure that any new staff were trained before recruiting and that important messages were continually and correctly reinforced (see *Appendix 2*).

Third, we instituted a programme of regular monitoring of the characteristics of patients who were recruited to the two trial arms, the number of cardiac arrests in each arm when no resuscitation attempt was made and the proportion of cardiac arrests included in the trial in order to detect any imbalances that may be caused by different thresholds for resuscitation. We also monitored the presenting rhythm, proportion of witnessed and unwitnessed arrests, presence of bystander CPR and time from '999' call to crew arrival (using ambulance computer log data). If a lower threshold for attempting resuscitation in the LUCAS-2 arm existed, then we would find a greater number of recruits and a greater proportion of cardiac arrests with resuscitation attempts, a greater proportion with unfavourable presenting rhythms, a lower

proportion of witnessed arrests and with bystander CPR and longer times from '999' call to start of resuscitation in the LUCAS-2 group.

Finally, if necessary, we corrected for any inclusion bias in the statistical analysis of the trial, by adjustment of the analysis to take account of imbalance in factors such as presenting rhythm, time since '999' call and presence of bystander CPR. We expected any potential inclusion bias to affect only the group of patients who were least likely to survive and that it would not affect patients in whom a resuscitation attempt would always be made (e.g. those with presenting rhythms with the highest probability of survival) and therefore a comparison between the LUCAS-2 device and manual compression in the subgroups of patients in whom resuscitation was known to be appropriate would be unaffected.

Monitoring device usage

The LUCAS-2 devices continuously record data when switched on. Data on the date, time and duration of use are stored in the device's internal memory and can be downloaded when the device is serviced. We intended to use these data to verify whether or not the LUCAS-2 device was used for all cardiac arrests in the LUCAS-2 group or any in the control group. However, in practice, obtaining access to the data was difficult, as they can be accessed only by the manufacturers at the time of device servicing and special software is required to interpret the data. Data were extracted from the devices during recruitment, and supplied to the trial team, but, through efforts to match up LUCAS-2 device usage with dates and times of resuscitations of recruited patients, it became apparent that it was possible to verify LUCAS-2 device use during resuscitation for only a small number of patients. The main reasons for this were, first, the lack of LUCAS-2 device clock synchronisation with the Universal Time clock; second, the difficulty of identifying the dates and times of LUCAS-2 device use for a resuscitation attempt, as opposed to device testing, demonstration or training; and, third, the lack of correspondence between the times of use recorded by the devices and those of recruitments recorded by ambulance services. Efforts to verify LUCAS-2 device use for resuscitation attempts based on the data recorded by the devices were discontinued.

Compliance was monitored by the direct report of ambulance service personnel on the patient report form (PRF). For each cardiac arrest, ambulance clinicians were asked to report whether or not the LUCAS-2 device had been used, and instances of non-compliance were followed up with the crews involved by the paramedic research fellows.

Monitoring quality of cardiopulmonary resuscitation

For interpretation of the trial's results, it is helpful to understand the quality of CPR provided as standard care during the trial, as this may help to explain the observed differences. For example, if the CPR quality in the control group was extremely high, it would make it less likely that a treatment benefit would be seen in the LUCAS-2 group.

We originally planned to monitor CPR quality using data recorded by defibrillators during resuscitation attempts, from which we would calculate the compression fraction, that is, the percentage of time in which chest compressions are carried out (to ascertain pauses in the chest compressions). This would provide a measure of CPR quality in the control group and would allow verification of LUCAS-2 device use in the LUCAS-2 group. However, direct measurement of the quality of CPR in trial patients proved unachievable, for several reasons. First, different defibrillators were in use in the four ambulance services, which required different approaches to extract data. In two services, memory cards were required. These needed to be inserted before use, then removed and data extracted before the next use. This was operationally impractical. In the remaining two ambulance services, data were stored in the defibrillators, but extraction and analysis of them were challenging, and it proved to be extremely difficult to download the data reliably after resuscitation attempts. We were therefore forced to abandon attempts to collect data on CPR quality from trial patients.

Instead, we performed a study to estimate the 'background' CPR quality in each ambulance service. Approximately 20% of staff working in the trial areas were invited to take part in an evaluation of the quality of simulated CPR (using a manikin). Between February 2013 and June 2013 each staff member was asked to demonstrate ALS of an adult patient in VF, as they would do normally in the field. Data were recorded for around 5 minutes. The staff were able to work solo or as a double-person crew, whichever was their usual practice. We recorded compression depth, compression rate and compression fraction. Data were recorded anonymously and were not related back to staff performance.

Blinding

Because of the nature of the interventions, ambulance clinicians could not be blinded and were aware of treatment allocations. Control room personnel were blinded to the allocation of the ambulance service vehicles, to ensure that there was no bias in whether a LUCAS-2 device-containing or control vehicle was sent to an incident that was likely to be a cardiac arrest. Normally, the closest vehicle would be sent, which would not favour either LUCAS-2 or control arms of the trial. Ambulance service clinical staff were not blinded; vehicles randomly assigned to the LUCAS-2 arm were identified to them at the start of the shift during vehicle checks and through stickers in the cab and outside the vehicle.

Patients themselves were unconscious and therefore unaware of their treatment allocation at the time of the intervention, although 19 patients may have been subsequently unblinded by relatives or friends who were aware that the LUCAS-2 device was used. We sought to ensure blinding of outcome assessment as far as possible. Research nurses/paramedics assessing outcomes at 3 and 12 months' follow-up were blinded to treatment group and endeavoured to maintain their blinding during the follow-up assessments. Mortality is an objective outcome, and its assessment was very unlikely to be influenced by knowledge of the treatment allocation.

Training

Paramedics seconded to work on the trial, along with clinical educator staff, trained all of the operational ambulance staff to use the LUCAS-2 device. Because of vehicle movements and staff rotations, staff-serviced vehicles were randomly assigned to both LUCAS-2 and manual groups; hence, all staff would potentially treat patients in the intervention arm. Training was carefully designed by the ambulance services on the basis of the manufacturer's guidance. Because of the pragmatic design of this trial, training was developed in accordance with the process by which new technology would be introduced in routine practice into NHS ambulance services. This preparation included access to online training resources⁵⁶ and included 1–2 hours of face-to-face training, updated annually. Training covered the study protocol and procedures, how to operate the LUCAS-2 device and the importance of high-quality CPR. Training included hands-on device deployment practice with a resuscitation manikin and emphasised the importance of rapid deployment with minimum interruptions in CPR. A competency checklist was completed before authorising staff to deploy the LUCAS-2 device correctly (see *Appendix 2*). Research paramedics reviewed all cases and provided feedback to individual staff as required. The rate of device use and reasons for non-use were fed back to participating services on a quarterly basis.

Clinical management of patients in the trial

The clinical management of patients in the trial was undertaken in accordance with the details given in the trial protocol.

The CPR that was delivered to all of the patients followed the International Liaison Committee for Resuscitation, European Resuscitation Council and Resuscitation Council (UK) guidelines that were in force

during the study period. These guidelines are adopted for ambulance use by the JRCALC and the JRCALC's guidelines for clinical practice form the basis for all of the resuscitation attempts that are delivered by ambulance crews.⁵³ At the commencement of the trial, the 2005 resuscitation guidelines were in place, but new resuscitation guidelines were published on 18 October 2010⁵⁸ and incorporated by all ambulance trusts that were involved in the trial during the following 12 months. All standard ALS interventions were provided, including drug administration, defibrillation and advanced airway management as required.

In both arms, if the patient did not respond despite full ALS intervention and remained asystolic for > 20 minutes, the resuscitation attempt could be discontinued. Unless these criteria were met, resuscitation was continued and the patient was transported to the nearest emergency department with ongoing CPR.

Intervention arm

The LUCAS-2 device used in the trial was the latest version of the LUCAS-2 device, manufactured by Jolife AB and distributed by Physio-Control UK, Watford, UK.

Patients who were allocated to the intervention arm (LUCAS-2 device) received mechanical chest compressions in place of standard manual chest compressions.

On arrival, after confirming cardiac arrest, manual CPR was commenced while the LUCAS-2 device was prepared and applied. Following this, the initial cardiac rhythm was assessed. If the patient was in VF or VT then a countershock was administered in accordance with JRCALC/ALS guidelines. Operational experience showed that the LUCAS-2 device could be deployed within 20–30 seconds of arrival at the patient's location. Prior to intubation, compressions were provided using the 30 compressions/two ventilations mode. If the patient was intubated, asynchronous compressions and ventilations were provided, with a ventilation rate of 10 per minute.

Defibrillation was performed using the following sequence: pause LUCAS-2 device, analyse heart rhythm; if shock indicated, restart LUCAS-2 device, charge, deliver shock and continue CPR for 2 minutes. This minimised deleterious pre- and post-shock pauses in compressions. The LUCAS-2 device was used in place of standard chest compressions as long as continued resuscitation was indicated, including resuscitation in the field and during transport to hospital.

The trial intervention ceased after care was handed over to the medical team in the hospital or the patient was declared deceased according to the ROLE criteria.⁵³

Manual chest compression arm

On arrival, after confirming cardiac arrest, manual CPR was commenced and the initial cardiac rhythm was assessed. If the patient was in VF or pulseless VT, then a countershock was applied. Prior to intubation, compressions were provided using the 30 compressions/two ventilations mode. If the patient was intubated, asynchronous compressions and ventilations were provided, with a ventilation rate of 10 per minute.

Minimising interruptions in chest compressions is critical for optimising the chances that a shock is successful. However, it is currently considered unsafe to perform defibrillation during manual chest compression. Defibrillation was therefore performed using current UK recommendations, which are as follows: stop CPR; analyse heart rhythm, charge defibrillator, deliver shock, restart chest compressions and continue CPR for 2 minutes.

Serious adverse event reporting

Definitions

Adverse events

An adverse event (AE) is 'Any untoward medical occurrence in a patient or clinical investigation participant taking part in health-care research, which does not necessarily have a causal relationship with the research'.⁵⁹

Serious adverse events

The definition of a serious adverse event (SAE) is an untoward and unexpected occurrence that:

- results in death
- is immediately life-threatening
- requires hospitalisation or prolongation of existing hospitalisation
- results in persistent or significant disability, or incapacity
- consists of a congenital anomaly or birth defect (not relevant to this trial population).⁵⁹

Additional terms for device trials

For trials of devices, additional terms are used and are defined as follows.

Adverse device effect/event

Any unfavourable or unintended response to a medical device.

Serious adverse device effect/event

A serious adverse device effect/event (SADE) is an adverse device effect/event (ADE) that has resulted in any of the consequences of a SAE or might have led to those consequences if suitable action/intervention had not been taken.

Incident

Any malfunction or deterioration in the characteristics and/or performance of a device, as well as any inadequacy in the labelling or instructions for use, which, directly or indirectly, might lead or might have led, to the death of a patient or user, or other persons or to the serious deterioration in their state of health.⁵⁹

Events that should be reported

All AEs and SADEs and incidents were reported to the trial co-ordinating centre on the appropriate forms (see *Appendix 3*).

All of the patients in this trial were in an immediately life-threatening situation; many would not survive and all of those who did were hospitalised. These situations were, therefore, expected, and events leading to any of them were reported as SAE/SADEs only if their cause was clearly separate from the cardiac arrest. Events that were related to cardiac arrest and would be expected in patients undergoing attempted resuscitation (including death and hospitalisation) were not reported.

Therefore, events were reported as SAE/SADEs if they were:

- serious
- *and* were potentially related to trial participation (i.e. they may have resulted from study treatment such as use of the LUCAS-2 device)
- *and* were unexpected (i.e. that the event was not an expected occurrence for patients who have had a cardiac arrest).

Examples of events that may be SAE/SADEs were the use of the LUCAS-2 device causing a new injury that endangered the patient, malfunction of the device causing injury to ambulance clinicians and malfunction of the device leading to inadequate chest compression.

Reporting serious adverse events

Events satisfying the criteria given above were reported to the study co-ordinating centre, using the event report form, as soon as they became apparent (see *Appendix 3*).

The SAE/SADE reports that were received by the co-ordinating centre were reviewed on receipt by the chief investigators, and those that were considered to satisfy the criteria for being related to the device and unexpected were notified to the main REC, the Medicines and Healthcare products Regulation Agency (MHRA) and manufacturer within 15 days of receipt.

The SAE reports were also reviewed by the Data Monitoring Committee (DMC) at its regular meetings. AEs that were not considered to be serious were logged and included in annual progress reports.

Data collection

Identification of cardiac arrests

Data were recorded on all of the cardiac arrests within the trial areas. This allowed assessment of the proportion of cardiac arrests that were enrolled into the trial and helped to ensure that no eligible cardiac arrests were missed. Data were collected by the attending ambulance clinicians, using the routinely completed PRF. Data from the PRFs were then transcribed on to the trial case report forms (CRFs) by the trial research fellows (see *Appendix 4*). The data collection was retrospective and each ambulance service had its own system, which meant that identifying cardiac arrest cases was challenging. The ambulance services, generally, had more than one system for identifying cardiac arrest cases to ensure that none was missed. One ambulance service had to go through all daily paper PRFs on station; others had electronic PRFs and were able to perform searches through a database. Other methods included linking in with national reporting of cardiac arrests to the Department of Health.

Data forms were collected in a central place at participating ambulance stations and collected by research paramedics on a weekly basis. For ineligible cardiac arrests (no resuscitation attempt, aged < 18 years, pregnant, traumatic aetiology, non-trial vehicle was first on scene), the ambulance service also sent the trial co-ordinating centre details of the arrests for monitoring purposes.

Hospitals did not undertake prospective data collection for trial participants because of the logistical difficulties that this would present. Hospitals were contacted, as necessary, to seek information about whether patients had been discharged or had died in hospital before contacting them for follow-up. Further details about length of stay in the ICU and hospital were also sought from hospitals, ICNARC and Hospital Episode Statistics (HES). Authority was granted by the Confidentiality Advisory Group to collect these data without seeking consent from the next of kin.

Deaths

Before admission

Deaths before admission to hospital were recorded by ambulance services and data for these patients were supplied to the trial database in anonymised form, as no personal identifiers were needed for follow-up. If a patient was transported to hospital, before transfer of identifiable data to the study co-ordinating centre, ambulance services conducted their own checks for survival. When access was granted locally, research fellows were able to search NHS Summary Care Records. They would also check with hospitals, where relevant.

To identify later deaths, all of the potential survivors had their status checked with MRIS approximately 6 weeks after their cardiac arrest. Therefore, the majority of deaths should have been included in the MRIS database. Deaths are normally included within 4 weeks of issue of a death certificate and we anticipated that the majority of certificates would be issued within a few days. All survivors were flagged on the MRIS database to ensure that the study was notified immediately if their death was registered. Issue of a death certificate may be delayed in some cases by referral to a coroner, but, in most cases, the coroner's investigation will be concluded quickly and the delay to inclusion of the death on the MRIS database will be small. In addition, before writing to patients we also contacted their GP (if known) to check on survival.

At follow-up

Survivors were followed up approximately 90 days after their cardiac arrest, by a home visit or telephone contact from a study research nurse/paramedic. At this visit quality-of-life tools (SF-12⁴³ and EQ-5D⁴⁴) and an assessment of CPC score were completed.

If a patient was believed to be alive but had not responded to the invitation to take part in the follow-up or did not want to take part, we approached his/her GP, hospital or ambulance service for any repeat visits for information on the patient's CPC score.

The second follow-up visit at 12 months included measurement of quality of life (SF-12⁴¹ and EQ-5D⁴²), anxiety and depression (HADS⁴⁷), post-traumatic stress (PCL-C⁴⁸) and cognitive outcome (MMSE⁴⁶). The NHS Demographics Batch Service was used to identify participants who had changed address since the last contact. Health service and social care resource use was reported in a patient self-completed questionnaire that was provided to participants at the 3- and 12-month follow-up visits (see *Appendix 5*).

Data management

All of the data collected during the trial were handled and stored in accordance with the Data Protection Act 1998.⁶⁰ Data were, as far as possible, anonymised, but this trial involved the use of identifiable personal data for follow-up. All transfer of data between ambulance services and the study co-ordinating centre used secure methods, such as encrypted e-mail. All of the study data were entered into a study-specific database, which was set up by the programming team at the WCTU at the start of the study. All specifications (i.e. database variables, validation checks, screens) were agreed between the programmer, statistician, chief investigators and trial co-ordinator. All trial documentation and data were archived after completion of the trial and are stored in accordance with the WCTU standard operating procedures⁶¹ (see *Appendix 7*).

Statistical methods

Power and sample size

Incidence of primary outcome

At the time of initiation of this trial, there were few data on the incidence of survival after cardiac arrest, and most of these referred to survival to hospital discharge rather than survival to 30 days. However, as most mortality will occur in the first days after cardiac arrest, we expected survival to hospital discharge and to 30 days to be similar. A systematic review, published in 2005,⁶² has summarised all European data. The overall incidence of survival to hospital discharge was 10.7%, with 21.2% survival to discharge for patients with an initial rhythm of VF. This review⁶² included eight studies from the UK, in which the mean survival to hospital discharge was 8.1% overall and 17.7% for patients with initial VF rhythm. Data on survival to discharge from audits of UK ambulance services were limited, because at the time of the study few ambulance services collected outcome data for patients beyond admission to hospital. Figures from the London Ambulance Service (2006–7) indicated a survival rate to discharge of 5.2% (95% CI 4.4% to 6.0%).⁶³ National audit data for England (2006) indicate that the proportion of patients for whom resuscitation is attempted (and who have ROSC at admission to hospital) varied between 10% and 26% for different ambulance services.⁶⁴ The overall national figure (2004–6) was 14–16%. Estimates of mortality in hospital vary from 50% to 70%; hence, the incidence of survival to discharge is expected to be between 4.5% and 8%.⁶⁵ A reasonable conservative estimate of survival to 30 days is 5% and we have used this value in the sample size calculations.

Intracluster correlation coefficient

No data currently exist from which a relevant intracluster correlation coefficient (ICC) for this trial can be calculated. We have therefore assumed a conservative value of 0.01 for the sample size calculation. We expected that, because the LUCAS-2 device and manual compression clusters recruited from the same geographical areas and hence the same populations, the ICC would be low. The value of the ICC was monitored at the interim analyses by the DMC.

Cluster size

Predicting the expected cluster size during the trial was difficult because of expected changes in the vehicles in service and the proportion of eligible cardiac arrests that they were likely to attend. Moreover, there was likely to be considerable variation in the number of cardiac arrests attended by each vehicle (i.e. variation in cluster size). Data from the West Midlands Ambulance Service suggested that each vehicle

would attend around 10–20 cardiac arrests per year; allowing for non-resuscitations and periods off the road, a reasonable estimate of the cluster size over a 2-year recruitment period was 15.

The sample size was revised during recruitment in response to information that some of the parameters differed from the assumptions that were made at the start of the trial. The original sample size calculation is given, followed by the revised version.

Original sample size

The required sample size is sensitive to variation in several parameters that were not precisely known at the start of the trial, including the incidence of the primary outcome in the manual compression group and the ICC. We aimed to be able to detect, with 80% power, an increase in the incidence of survival to 30 days from 5% in the manual compression group to 7.5% in the LUCAS-2 group [a risk ratio (RR) of 1.5]. An increase in survival from 5% to 7.5% corresponds with a number needed to treat of 40 – or one extra life saved per 40 resuscitation attempts. This would translate into around 625 lives saved per year in the UK. In an individually randomised trial this would require 2942 participants. Allowing for clustering, assuming an ICC of 0.01 and a cluster size of 15, this would require 224 clusters if using a 1 : 1 randomisation ratio (112 LUCAS-2 group, 112 manual group; 3360 participants in total).

Because the number of LUCAS-2 devices that were available to the trial was limited, it was more efficient not to use a fixed 1 : 1 randomisation ratio (see *Randomisations*), but to randomise a number of LUCAS-2 devices among all of the vehicles at each ambulance station. This allowed inclusion in the trial of all cardiac arrests attended by vehicles from that station. The numbers of clusters required for 80% power to detect the difference specified above, with different randomisation ratios and cluster sizes, is shown in *Table 1*.

Our target was to randomise 82 LUCAS-2 clusters and 163 standard care clusters and a total sample size of 3675 participants. We expected to determine the primary outcome for close to 100% of trial participants, so no inflation of the sample size to allow for losses to follow-up of individual participants was proposed. With this sample size, the 95% CI around an estimated treatment effect of a RR of 1.50 would be 1.14 to 1.94, including adjustment for clustering.

Within this sample size we expected around 25% of patients to have an initial rhythm of VF (approximately 920 patients). This subgroup was expected to have significantly higher survival than the rest of the

TABLE 1 Number of clusters required for 80% power to detect an increase in the incidence of survival to 30 days in the manual compression and LUCAS-2 groups

Cluster size	Control	Clusters required			Total number of participants
		Total	LUCAS-2	Control	
14	1 : 1	238	119	119	3332
	1 : 2	260	87	173	3640
15	1 : 1	224	112	112	3360
	1 : 2	245	82	163	3675
16	1 : 1	212	106	106	3392
	1 : 2	231	77	154	3696
18	1 : 1	192	96	96	3456
	1 : 2	210	70	140	3780
20	1 : 1	176	88	88	3520
	1 : 2	192	64	128	3840

population, of around 15%. The number in this subgroup was sufficient to show an increase from 15% to 22.8% (RR 1.52) with 80% power, allowing for clustering.

The DMC monitored the values of all of the parameters of the sample size calculation at interim analyses and advised on any necessary modifications to the sample size.

Revision to sample size

The target sample size was reviewed in September 2012, after recruitment of 2469 patients, in response to an observed high level of non-compliance in the LUCAS-2 arm and to incorporate updated figures for the expected cluster size, ICC and ratio of control to LUCAS-2 clusters. The sample size re-estimation did not use any information from comparisons between the trial groups.

Because non-compliance would reduce the difference between the groups and potentially obscure a treatment effect due to the LUCAS-2 device, we used complier average causal effect (CACE) analysis^{66,67} as well as ITT analysis. This approach estimates the unadjusted odds ratio (OR) for the treatment effect among compliers, without introducing bias by ignoring the random assignment to groups. For re-estimating the sample size, we defined compliance in the LUCAS-2 group as use of the device, or non-use for legitimate reasons that would preclude its use in normal clinical practice (such as patients in whom the LUCAS-2 device was contraindicated or if space restriction meant that the LUCAS-2 device could not be deployed). Using this definition, we estimated that compliance would be around 70% at the end of the trial.

The expected average cluster size was calculated to be approximately nine and the control-to-LUCAS-2 ratio was 1.5 : 1. It was not possible to calculate an ICC from the interim trial data, but it was expected to be low and a lower value than was assumed in the original calculation (0.001 rather than 0.01) was used.

Using these figures, a sample size of 4344 would maintain the original power of the trial to detect an increase in survival from 5% to 7.5%, using CACE analysis rather than ITT analysis. The change to the sample size was approved by the DMC and TSC and the revised target of 4344 was adopted in December 2012.

Statistical analysis

We performed ITT analyses to estimate the treatment effect of the LUCAS-2 device and presented results as a point estimate (RR or mean difference), with uncertainty estimated by the 95% CI.

We also used CACE analyses to estimate the effect in cardiac arrests when the protocol was followed.⁶⁶ CACE estimates the treatment effect in people who were randomly assigned to the intervention and who actually received it, by comparing compliers in the intervention group with those participants in the control group who would have been compliers if they had been allocated to the intervention group. This analysis retains the advantages of randomisation and avoids introducing bias, hence CACE is preferred to per-protocol analysis.⁶⁷ CACE assumes that the probability of non-compliance with the LUCAS-2 device would be the same for people who were actually randomised to the control as for those who were randomised to the LUCAS-2 arm. If allocation is random, this assumption will hold. A second assumption is that outcomes are not affected just by being randomised to the LUCAS-2 or control groups; in other words, there is no systematic difference in outcomes between patients attended by LUCAS-2 device-containing vehicles and those attended by control vehicles, except that caused by the different treatments provided. CACE analysis enables us to estimate the unobserved proportion of the control group who would have been non-compliers if randomised to the LUCAS-2 group. We did two CACE analyses, defining compliers in different ways. In CACE 1, we treated as non-compliant those cases in which the LUCAS-2 device was not used for unknown or trial-related reasons that would not occur in real-life clinical practice (e.g. crew was not trained in trial procedures, crew misunderstood the trial protocol, the device was missing from the vehicle). This analysis omits trial-related non-use and should be a better estimate of the treatment effect in real-world clinical practice than an ITT analysis. In the CACE 2 analysis, we treated as compliant only those cases in which the LUCAS-2 device was actually used and this analysis therefore estimates efficacy, that is, the treatment effect in patients who received LUCAS-2 device treatment.

For ITT analyses, we used logistic regression models to obtain unadjusted and adjusted ORs and 95% CIs. The prespecified covariates used in the adjusted models were age, sex, response time, bystander CPR and initial rhythm. We attempted adjusting for the clustering design using multilevel logistic models using the Statistical Analysis Software (SAS) GLIMMIX procedure with logit link function based on the binomial distribution. Because of the extremely low survival rates in each cluster (vehicle), the multilevel models could not be fitted with the vehicle random effect, as this effect was not estimable. As a result, ordinary logistic regressions were fitted. We also undertook prespecified subgroup analyses by (1) initial rhythm (shockable vs. non-shockable); (2) cardiac arrest witnessed versus not witnessed; (3) type of vehicle (RRV vs. ambulance); (4) bystander CPR versus no bystander CPR; (5) region; (6) aetiology (presumed cardiac or non-cardiac); (7) age; and (8) response time. The analyses by region and type of vehicle were added during recruitment on the recommendation of the TSC. We fitted logistic regression models for the primary outcome measure with the inclusion of an interaction term to examine whether or not the treatment effect differed between the subgroups. Age and response times are continuous variables and we assessed these using multivariate fractional polynomials⁶⁸ (see *Appendix 8*).

We did all analyses using SAS version 9.3 (SAS Institute, Marlow, UK). Interim analyses were conducted at least once per year during recruitment and supplied confidentially to the DMC. The DMC considered the results of the interim analysis and made recommendations to the TSC about continuation of recruitment or any modification to the trial that may have been necessary.

Approvals, registration and governance

The study was approved by the Coventry REC (reference number 09/H1210/69) and sponsored by the University of Warwick. It was conducted in accordance with the principles of good clinical practice and the Mental Capacity Act (2005).^{54,69} The trial was registered on the International Standard Randomised Controlled Trial Number Register (ISRCTN08233942). Approval was given by the National Information Governance Board for Health and Social Care Ethics and Confidentiality Committee for access to personal data without consent (reference number ECC 2–02 (c)/2011). The manufacturers (Jolife AB) and distributors (Physio-Control UK) of the LUCAS-2 device had no role in the design, conduct, analysis or reporting of the trial. Their role was limited to supply and servicing of the LUCAS-2 devices and training of study co-ordinating centre personnel.

Several changes to the protocol and procedures were made during the trial (see *Table 2*). When these fulfilled the definition of 'substantial amendments' according to the UK Clinical Trials regulations, they were reviewed and approved by the ethics committee.

Staffing

The trial was co-ordinated by a team based at the WCTU. The exact personnel varied during the course of the trial but included a trial co-ordinator (who had overall management responsibility for the team), trial administrator, data manager and research nurse (who was responsible for co-ordinating follow-up) (*Figure 3*). The statistician, senior project manager and programmer were also based at the WCTU. Each ambulance service employed a number of research paramedics, who were seconded to the trial for its duration and had primary responsibility for delivering the trial in their area. They were based with the ambulance services, but worked closely with the central co-ordinating team. Their role was to deliver training, manage the devices and organise data collection. Some of the research paramedics additionally performed follow-up visits. These personnel were key to the successful delivery of the trial. As active paramedics, they had detailed knowledge of the procedures and challenges of their own ambulance service, and were able to design systems and procedures that would be successful in their area.

Protocol amendments

There have been 11 substantial and non-substantial amendments to the trial documentation (*Table 2*).

(a)

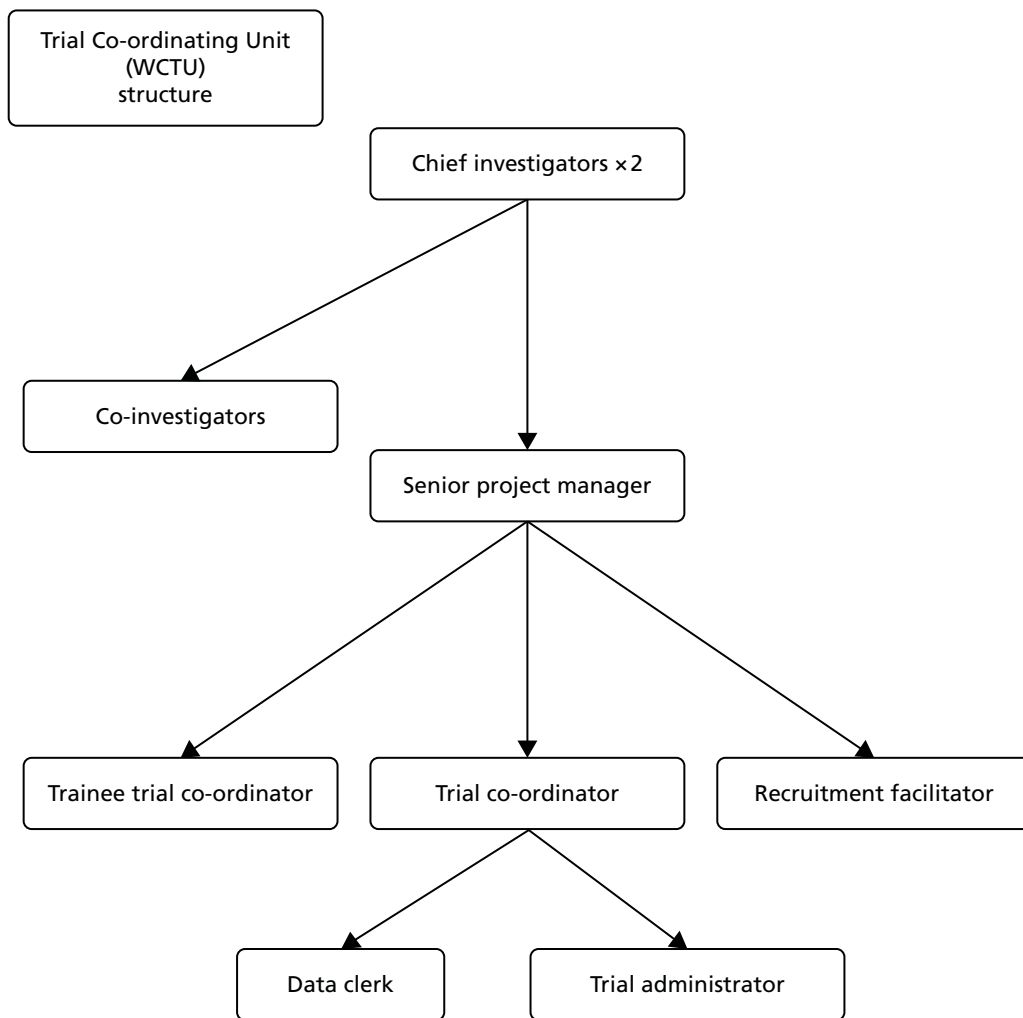

(b)

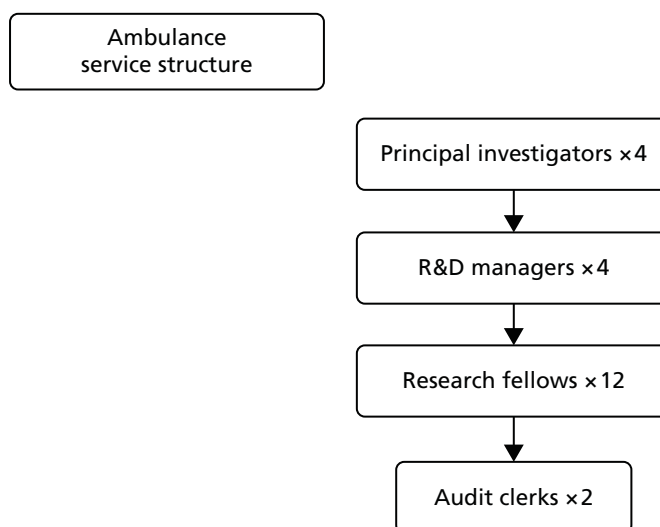

FIGURE 3 Staff organogram. R&D, research and development.

TABLE 2 Protocol amendments

Date of amendment	Amendment no.	Document(s) affected	Changes	New version number, date	Date approved by REC – Coventry	Date approved by lead R&D
23 April 2015	11	N/A	MSc project: contact survivors enrolled in the PARAMEDIC trial to explore patient views and experiences of being	N/A	5 May 2015	
17 February 2015	10	N/A	Enrolled in an emergency care trial with a waiver of consent			
1 May 2013	9	Protocol, PIS	Extension to end date of trial to end of June 2015 Clarifications to protocol, revised patient letters	N/A Version 4.3, 1 April 2013	5 March 2015 6 June 2013	N/A 8 July 2013
4 March 2013	8	Protocol	Revised sample size of 4344	Version 5.1, 1 April 2013 Version 4.2, 4 March 2013	25 March 2013	3 April 2013
8 November 2012	7	N/A	MSc dissertation to go a full amendment	N/A	21 November 2012	24 June 2013
12 June 2012	6	PIS, ICF	Revise patient letter and add in another contact at 12 months	Version 5.0, 12 June 2012	3 July 2012	9 July 2012
5 April 2012	5	N/A	Letter to inform REC of reward scheme (pilot) in Coventry area	N/A	11 May 2012	9 July 2012
29 March 2012	N/A	N/A	Letter to inform REC of Ian Jones' dissertation	N/A	13 July 2012	
22 December 2011	4 (minor amendment 2)	Information sheets	Minor changes to the invite letter and information sheets so that if we are doing only a 12-month visit the documents make more sense	Version 4.1, 15 December 2011	22 December 2011	6 January 2012
14 June 2011	3 (minor amendment 1)	N/A	Clarification that we will seek information from hospitals with regard to secondary outcomes	N/A	20 June 2011	13 July 2011

Date of amendment	Amendment no.	Document(s) affected	Changes	New version number, date	Date approved by REC – Coventry	Date approved by lead R&D
21 March 2011	2	Protocol	Sample size change Approaching survivors now we have NIGB approval Change from 'paramedics' to 'ambulance clinicians' throughout	Version 4.1, 21 March 2011	4 May 2011	5 May 2011
21 March 2011	2	Information sheets	Changes now we have NIGB approval Reply slip for patient representative to reply on behalf of patient	Version 4.0, 16 December 2010	4 May 2011	5 May 2011
21 March 2011	2	Consent form	Changes to consultee form – title changed from 'Consent' to 'Agreement'. [Patient name] added instead of friend/relative, etc.	Version 4.0, 16 December 2010	4 May 2011	5 May 2011
12 August 2010	1	Protocol	Several minor changes to text throughout, highlighted in yellow Change to primary outcome sections 2.2.1 and 2.3 Changes to sample size in section 2.4.4 Clarification of process if the first resource on scene is not a trial vehicle (section 2.5.2) Changes to section 2.10: Protection against bias: addition of subheadings Sections '7.3 Relationship with manufacturer' and '8.4 Training' added in Clarification that data will be collected for all of the cardiac arrest patients attended by trial vehicles, non-trial vehicles and those for which resuscitation attempts were not made for monitoring purposes. Only eligible cardiac arrests will be followed up and included in the analysis	Version 3.0, 12 August 2010	16 September 2010	11 October 2010 (WMAAS only)
			Addition of device related event capture to section 4			

continued

TABLE 2 Protocol amendments (continued)

Date of amendment	Amendment no.	Document(s) affected	Changes	New version number, date	Date approved by REC – Coventry	Date approved by lead R&D
12 August 2010	1	Information sheets 1 and 2	Addition of trial ID to information sheet 1 Change of version and date to information sheets 1 and 2	Version 3.0 , 12 August 2010	16 September 2010	11 October 2010 (WMAS only)
12 August 2010	1	N/A	Use of £5 vouchers for training paramedics Change to PIs: Scotland, B. Mason to G. Egan; and, West Midlands, R Cooke to G Bennett		16 September 2010	11 October 2010 (WMAS only)

ICF, informed consent form; ID, identification; N/A, not applicable; MSc, Master of Science; NIIGB, National Information Governance Board for Health and Social Care; PI, principal investigator; PIS, patient information sheet; R&D, research and development; WMAS, West Midlands Ambulance Service.

Chapter 3 Trial results

Overview of recruitment

Recruitment of clusters

Four hundred and eighteen emergency vehicles (287 double-manned ambulances and 131 single-manned RRVs), at 86 ambulance stations, were included in the trial. One hundred and forty-seven vehicles (100 ambulances and 47 RRVs) were assigned to the LUCAS-2 group and 271 clusters (187 ambulances and 84 RRVs) were randomised to the control group (*Table 3* and *Figure 4*). The overall LUCAS-2-to-control ratio was 1 : 1.8 (1 : 1.87 for ambulances and 1 : 1.79 for RRVs). Seventy-two clusters were terminated early during the recruitment period, for a variety of reasons, including the vehicle being taken out of front-line service, scrapped or transferred to a station that was out of the trial area.

TABLE 3 Number of vehicles randomised, by trial arm, in each locality

Locality	Number of stations	Number of vehicles			
		Ambulance		RRV	
		LUCAS-2	Control	LUCAS-2	Control
West Midlands					
Birmingham	24	27	49	12	24
Black Country	14	12	25	4	9
Coventry & Warwickshire	8	14	27	10	16
South Central					
SCAS North	3	9	13	3	8
SCAS South	2	6	18	2	3
North East					
Durham	2	1	2	1	1
North Tyne	6	1	5	1	0
South Tyne	7	3	6	2	4
Teesside	1	3	4	1	4
Wales					
ABM East	3	4	9	3	3
ABM West	4	5	7	1	4
Cardiff	2	5	8	1	3
Llanelli	1	2	2	2	2
Newport	2	4	6	2	2
Vale of Glamorgan	2	4	6	2	1
Total		100	187	47	84

ABM, Abertawe Bro Morgannwg; SCAS, South Central Ambulance Service.

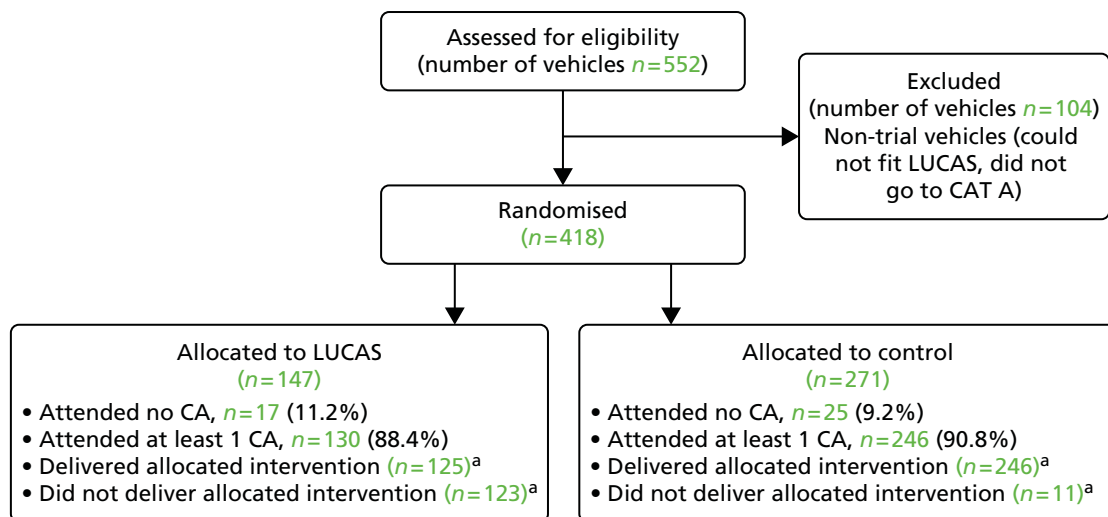

FIGURE 4 The Consolidated Standards of Reporting Trials (CONSORT) diagram for vehicles. a, A vehicle can be counted twice, as it can deliver/not deliver intervention on different occasions. Seventy-two (17%) of vehicles changed status. CA, cardiac arrest; CAT A, category A call.

Stations were opened for recruitment and vehicles were randomised between April 2010 and February 2013, so the duration of recruitment for each cluster varied between 4 and 38 months. The number of patients recruited by each vehicle was also very variable, ranging from 0 to 41 patients (*Figure 5*), with a mean cluster size of 13 patients in the LUCAS-2 arm and 11 in the control arm. Some of the zeros are accounted for by five stations with 17 vehicles that never commenced active recruitment. Individual ambulance staff attended on average 4.1 eligible cardiac arrests [standard deviation (SD) 3.6 eligible cardiac arrests] in the control group and 3.0 eligible cardiac arrests (SD 2.3 eligible cardiac arrests) in the LUCAS-2 group over the study period.

Recruitment of patients

Patients were recruited between 15 April 2010 and 10 June 2013. Recruitment began first in the West Midlands (start date 15 April 2010) and, subsequently, in the other regions (start dates: Wales, September 2011; South Central, October 2011; North East, May 2012). During the recruitment period there were 16,019 cardiac arrests attended by vehicles from participating stations and trial vehicles attended 11,171 emergency incidents. Cardiac arrest was confirmed and resuscitation was attempted in 4689 cases, of which 218 cases were ineligible and excluded. In total, 4471 patients were therefore enrolled in the study (*Figure 6*).

In the LUCAS-2 arm, 638 cases received manual chest compression and in the control arm 11 cases received LUCAS-2 chest compression (see footnote a to *Figure 6*).

The majority of patients were recruited in the West Midlands (2723/4471, 60.9%), with smaller proportions in the other three regions. RRVs were the first vehicle in attendance for 1635 out of 4471 (36.6%) recruits, whereas ambulances were the first vehicle on scene for 2836 out of 4471 (63.4%) recruits (*Table 4*).

Differences in baseline characteristics between the groups were small (*Table 5*). Slightly more patients in the manual CPR group had cardiac arrest at home [2336/2819 (82.9%) vs. 1336/1652 (80.9%)] and witnessed arrest [1749/2819 (62.0%) vs. 1001/1652 (60.6%)].

Cumulative recruitment through time is shown in *Figure 7*.

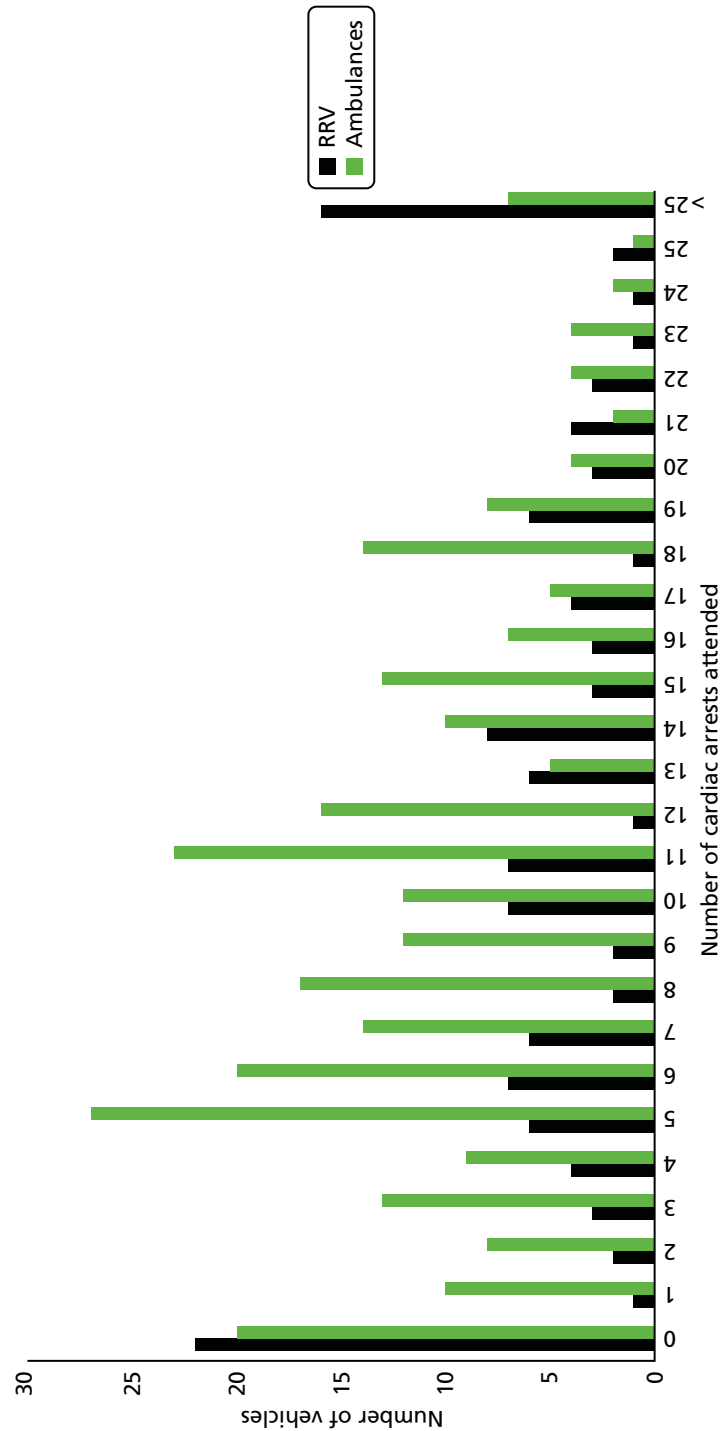

FIGURE 5 Number of vehicles attending different numbers of cardiac arrests.

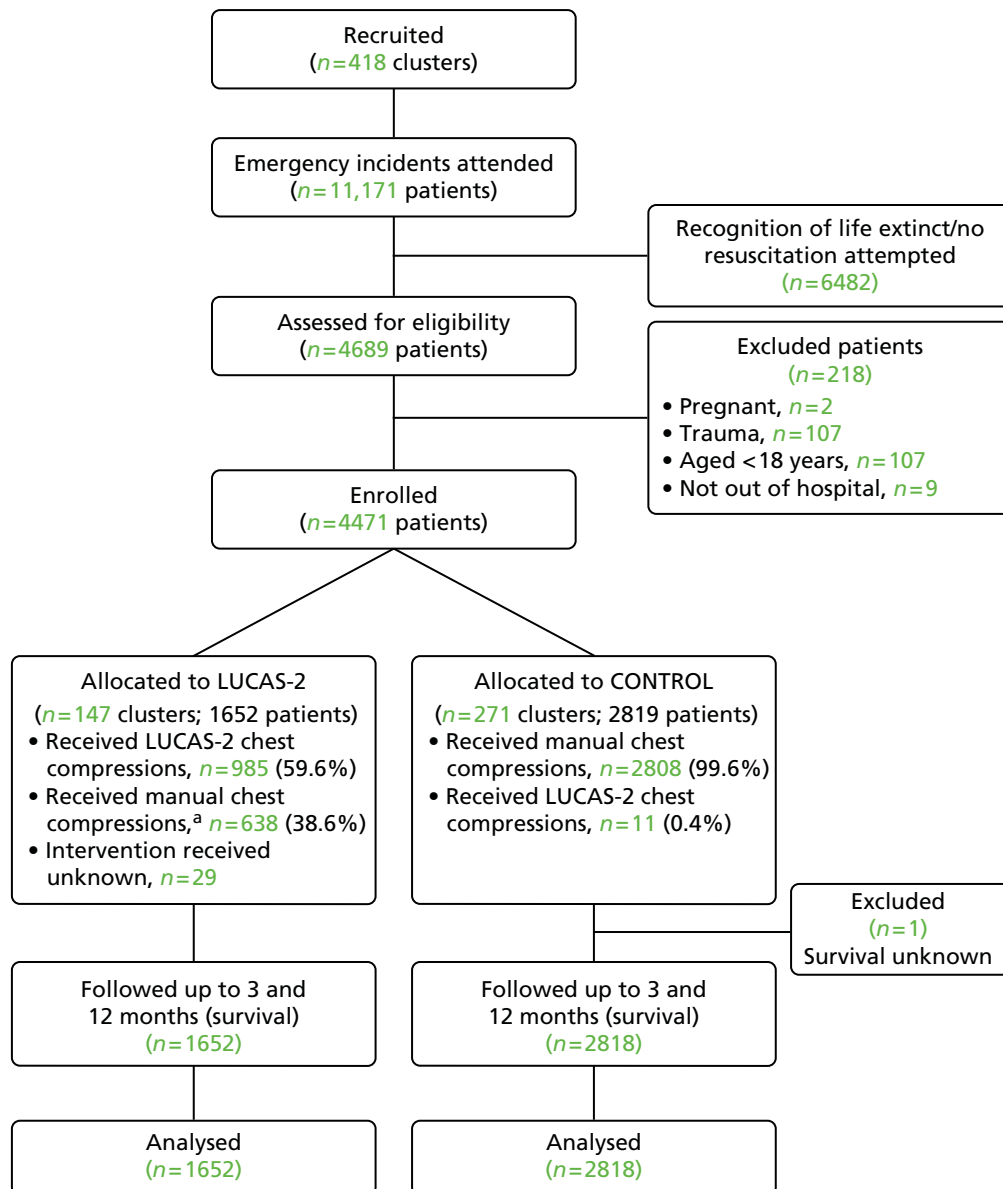

FIGURE 6 Patient flow chart. a, Reasons that the LUCAS-2 device was not used: crew not trained, 78; crew error, 168; no device in vehicle, 26; unsuitable patient, 102 [patient too large, 58; patient too small, 22; other reasons (e.g. chest deformity), 22]; device issues, 14; not possible to use device, 140; and reason unknown, 110. Reasons for the LUCAS-2 device use in control arm were crew error.

TABLE 4 Number of recruits by region and type of vehicle

Region	Treatment arm						Total number of patients (percentage of total)
	LUCAS-2			Control			
	Ambulance	RRV	Total	Ambulance	RRV	Total	
North East	80	106	186	226	131	357	543 (12.1%)
South Central	105	43	148	238	121	359	507 (11.3%)
Wales	230	116	346	231	121	352	698 (15.6%)
West Midlands	648	324	972	1078	673	1751	2723 (60.9%)
Total (percentage of total)	1063 (64.3%)	589 (35.7%)	1652	1773 (62.9%)	1046 (37.1%)	2819	4471

TABLE 5 Baseline characteristics

Characteristic	Treatment arm	
	LUCAS-2 (N = 1652)	Manual CPR (N = 2819)
Age (years)		
Mean (SD)	71.0 (16.3)	71.6 (16.1)
Sex, n (%)		
Male	1039 (63.0)	1774 (62.9)
Aetiology of cardiac arrest, n (%)		
Presumed cardiac	1417 (85.8)	2445 (86.7)
Respiration	125 (7.6)	191 (6.8)
Submersion	5 (0.3)	7 (0.3)
Unknown	48 (2.9)	74 (2.6)
Other (non-cardiac)	57 (3.5)	102 (3.6)
Location, n (%)		
Home	1336 (80.9)	2336 (82.9)
Public place	225 (13.6)	362 (12.8)
Other	91 (5.5)	121 (4.3)
Witnessed cardiac arrest, n (%)	1001 (60.6)	1749 (62.0)
Bystander	704 (42.6)	1223 (43.4)
EMS	250 (15.1)	449 (15.9)
Non-EMS health care	47 (2.8)	75 (2.6)
Not known	0	2 (0.1)
Bystander CPR before EMS arrival, n (%)	716 (43.3)	1238 (43.9)
Not known	90 (5.5)	168 (6.0)
Time (minutes) from emergency call to vehicle arrival, median (IQR)	6.5 (4.8–9.1)	6.3 (4.6–9.2)
Initial rhythm, n (%)		
VF	364 (22.0)	597 (21.2)
VT	12 (0.7)	18 (0.6)
PEA	398 (24.0)	707 (25.0)
Asystole	824 (49.9)	1384 (49.1)
Not known	54 (3.3)	113 (4.0)
Defibrillation before EMS arrival, n (%)	19 (1.2)	40 (1.9)

IQR, interquartile range.

Treatment

A substantial proportion of the patients who were randomised to the LUCAS-2 group (638/1652, 38%) did not receive mechanical chest compressions. This was expected because in clinical practice there would be occasions in which the LUCAS-2 device would not be used and it is appropriate to include these cardiac arrests in a pragmatic trial. The LUCAS-2 device was used for 985 out of 1652 patients (60%) in the LUCAS-2 arm; in 29 out of 1652 (1.8%) cases the intervention used was unknown. The LUCAS-2 device was not used for trial-related reasons in 272 cases and 256 cases of non-use were classified as being for

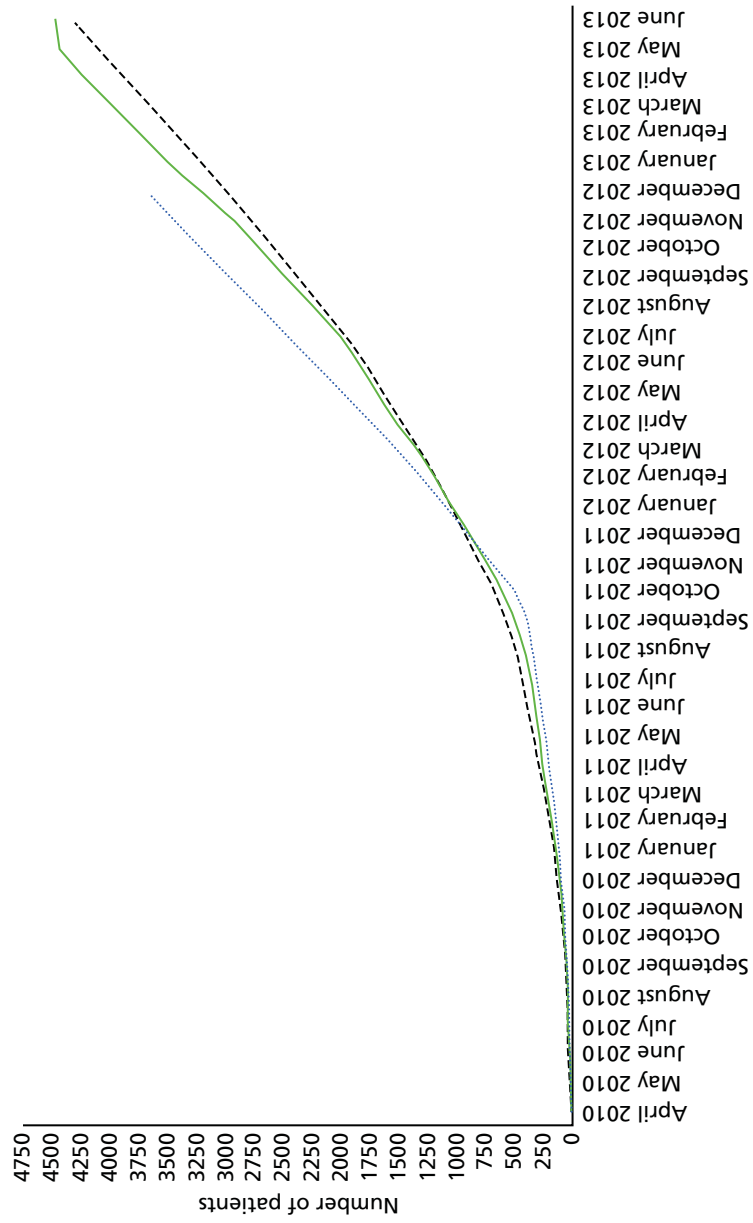

FIGURE 7 Cumulative recruitment: April 2010 to June 2013. Dotted line represents the original target recruitment; dashed line represents the revised target recruitment; and the green solid line represents actual recruitment.

reasons that would occur in normal clinical practice. The reason for non-use was not known for 110 cases. In the control arm, the LUCAS-2 device was used in 11 out of 2819 cases (0.4%) as a result of crew error.

Treatments used were similar between the trial arms, although the proportion of patients receiving intravenous drugs was slightly higher in the LUCAS-2 group (1366/1652, 82.7%) than in the control group (2255/2819, 80.0%) (Table 6).

Follow-up

The number of patients followed up with visits at 3 and 12 months was limited by lack of response to the initial contact and patients declining participation in the follow-up (Table 7): 146 out of 278 survivors (52.5%) were followed up at 3 months and 143 out of 264 survivors (54.2%) at 12 months. The proportion of patients visited was slightly lower in the LUCAS-2 group than in the control group (49.0% vs. 54.1%), raising the possibility that there may have been differential losses between the trial arms (Table 8).

TABLE 6 Treatment of cardiac arrest

Treatment	Treatment arm, n (% of total)	
	LUCAS-2 (N = 1652)	Manual CPR (N = 2819)
Intravenous drugs given	1366 (82.7)	2255 (80.0)
Not known	8 (0.5)	14 (0.5)
Intubated	749 (45.3)	1297 (46.0)
Not known	33 (2.0)	48 (1.7)
LMA/supraglottic airway device used	435 (26.3)	736 (26.1)
Not known	29 (1.9)	47 (1.7)
Transported to hospital	1099 (66.5)	1868 (66.2)
Status at handover		
ROSC	377 (22.8)	658 (23.3)
CPR in progress	640 (38.7)	1081 (38.4)
Unknown	82 (5.0)	129 (4.6)
Received allocated intervention	985 (59.6)	2808 (99.6)
Did not receive allocated intervention	638 (38.6)	11 (0.4)
Not known whether or not allocated intervention delivered	29 (1.8)	0 (0.0)
Reasons for non-use of LUCAS-2 device		
Reason unknown	110	
Not trained	78	
Crew error	168	
Not possible to use the LUCAS-2 device	140	
No device in vehicle	26	
Unsuitable patient	102	
Device issues	14	

LMA, laryngeal mask airway.

TABLE 7 Number of patients included and not included in 3- and 12-month follow-up

Follow-up	Treatment arm, n (% of total)		Total, n (% of total) (N = 4471)
	LUCAS-2 (N = 1652)	Control (N = 2819)	
From hospital discharge to 3-month follow-up			
Deceased prior to 3-month follow-up	1556 (94.2)	2636 (93.5)	4192 (93.8)
Death/alive status unknown	0 (0.0)	1 (0.0)	1 (0.0)
3-month follow-up			
Alive at 3-month follow-up	96 (5.8)	182 (6.5)	278 (6.2)
Follow-up complete (3-month visit done)	47 (2.8)	99 (3.5)	146 (3.3)
Patient declined (when contacted)	19 (1.2)	36 (1.3)	55 (1.2)
Lost to follow-up	28 (1.7)	47 (1.7)	75 (1.7)
Patient died (before visit could be done)	2 (0.1)	0 (0.0)	2 (0.0)
From hospital discharge to 12-month follow-up			
Deceased prior to 12-month follow-up	1563 (94.6)	2643 (93.8)	4206 (94.1)
Death/alive status unknown	0 (0.0)	1 (0.0)	1 (0.0)
12-month follow-up			
Alive at 12-month follow-up	89 (5.4)	175 (6.2)	264 (5.9)
Follow-up complete (12-month visit done)	48 (2.9)	95 (3.4)	143 (3.2)
Patient declined (when contacted)	17 (1.0)	33 (1.2)	50 (1.1)
Lost to follow-up	23 (1.3)	43 (1.5)	66 (1.5)
Withdrew	1 (0.1)	4 (0.1)	5 (0.1)
Patient died (before visit could be done)	0 (0.0)	0 (0.0)	0 (0.0)

TABLE 8 Baseline characteristics for all those patients with 3-month data (N = 146)

Characteristic	Treatment arm	
	LUCAS-2 (N = 47)	Control (N = 99)
Age (years)		
Mean (SD)	60.6 (14.7)	63.1 (14.1)
Sex		
Male, n (%)	35 (75)	73 (74)
Aetiology of cardiac arrest, n (%)		
Presumed cardiac	42 (89.4)	94 (95.0)
Traumatic	0 (0.0)	0 (0.0)
Respiration	5 (10.6)	3 (3.0)
Submersion	0 (0.0)	0 (0.0)
Unknown	0 (0.0)	0 (0.0)
Other (non-cardiac)	0 (0.0)	2 (2.0)

TABLE 8 Baseline characteristics for all those patients with 3-month data (*N* = 146) (*continued*)

Characteristic	Treatment arm	
	LUCAS-2 (<i>N</i> = 47)	Control (<i>N</i> = 99)
Location, <i>n</i> (%)		
Home	26 (55.3)	57 (57.6)
Public place	16 (34.0)	34 (34.8)
Other	5 (10.6)	8 (8.1)
Not known	0 (0.0)	0 (0.0)
Witnessed cardiac arrest, <i>n</i> (%)	40 (85.1)	90 (90.9)
Bystander	24 (60.0)	52 (57.8)
EMS	15 (37.5)	34 (37.8)
Non-EMS health care	1 (2.5)	4 (4.4)
Not known	2 (4.2)	3 (3.0)
Bystander CPR before EMS arrival, <i>n</i> (%)	18 (38.8)	36 (36.4)
Not known	0 (0.0)	5 (5.1)
Time (minutes) from emergency call to vehicle arrival		
Median	5.9	5.9
IQR	4.2–7.0	4.3–8.2
Range	2.5–56.8	2.1–30.4
Initial rhythm, <i>n</i> (%)		
VF	37 (78.7)	79 (79.8)
VT	3 (6.4)	3 (3.0)
PEA	4 (8.5)	10 (10.1)
Asystole	2 (4.3)	2 (2.0)
Not known	1 (2.1)	5 (5.1)
Defibrillation before EMS arrival, <i>n</i> (%)	1 (2.1)	2 (2.0)
Not known	0 (0.0)	1 (1.0)

IQR, interquartile range.

Outcomes: intention-to-treat analysis

Survival status could not be ascertained for one patient, who was from overseas and returned home < 30 days after the cardiac arrest, but it was known up to 12 months for all of the other participants. In the ITT analysis, 30-day survival was similar in the LUCAS-2 and control groups [LUCAS-2, 104/1652 (6.3%); control, 193/2818 (6.8%); adjusted OR 0.86, 95% CI 0.64 to 1.15].

The analyses did not show a clear advantage to the LUCAS-2 group for any outcome; there was very little effect of the LUCAS-2 device on ROSC (OR 0.99, 95% CI 0.86 to 1.14) and survived event (OR 0.97, 95% CI 0.82 to 1.14), but for survival at 30 days, 3 months and 12 months the point estimates favoured manual chest compression, although the 95% CIs included 1. The number of patients surviving with a favourable neurological outcome (i.e. a CPC score of 1 or 2) was lower in the LUCAS-2 group than in the control group (adjusted OR 0.72, 95% CI 0.52 to 0.99; *Table 9*).

TABLE 9 Outcomes: adjusted ORs are adjusted for age, sex, response time, bystander CPR and initial rhythm

Outcome	Treatment arm, n (% of total)		OR (95% CI)	
	LUCAS-2 (N = 1652)	Control (N = 2819)	Unadjusted	Adjusted
Survival to 30 days	104 (6.3)	193 (6.9)	0.91 (0.71 to 1.17)	0.86 (0.64 to 1.15)
Not known	0 (0.0)	1 (0.04)		
ROSC	522 (31.6)	885 (31.4)	1.02 (0.89 to 1.16)	0.99 (0.86 to 1.14)
Not known	58 (3.5)	82 (2.9)		
Survived event	377 (22.8)	658 (23.3)	0.97 (0.83 to 1.14)	0.97 (0.82 to 1.14)
Not known	82 (5.0)	129 (4.6)		
Survival to 3 months	96 (5.8)	182 (6.5)	0.89 (0.69 to 1.15)	0.83 (0.61 to 1.12)
Not known	0 (0.0)	1 (0.04)		
Survival to 12 months	89 (5.4)	175 (6.2)	0.86 (0.60 to 1.12)	0.83 (0.62 to 1.11)
Survival with favourable neurological outcome (CPC score of 1 or 2)	77 (4.7)	168 (6.0)	0.77 (0.59 to 1.02)	0.72 (0.52 to 0.99)
CPC (%)				
1	67 (4.1)	153 (5.4)		
2	10 (0.6)	15 (0.5)		
3	14 (0.9)	10 (0.4)		
4	2 (0.1)	1 (0.0)		
5	1556 (94.2)	2636 (93.5)		
Not known	3 (0.2)	4 (0.1)		

Complier average causal effect analyses

The CACE 1 analysis included cases for which the LUCAS-2 device was not used in situations when it would not be used in normal clinical practice. Its results were similar to the ITT analysis, which suggests that there is no advantage to the LUCAS-2 device when used as it would be in routine clinical practice. In the CACE 2 analysis, which included only cases for which the LUCAS-2 device was actually used in the intervention group, the effects of the LUCAS-2 device, again, were similar to the ITT analysis, although the estimate for survival with a CPC score of 1 or 2 was slightly more extreme. Therefore, there was not a substantial difference in the treatment effect of the LUCAS-2 device when it was actually used. A concern with the ITT analysis is that because it includes a large number of non-compliant cases, any benefit among patients for whom the device was actually used would be diluted by a lack of effect among cases that were non-compliant, leading to underestimation of the treatment effect. The CACE analyses demonstrate that the lack of advantage to the LUCAS-2 device in the ITT analysis is not due to dilution of the treatment effect (Table 10).

Subgroup analyses

In the subgroup analyses there was no evidence of different treatment effects between the subgroups for 30-day survival according to whether or not the cardiac arrest was witnessed; the type of vehicle

TABLE 10 Results of CACE analysis

Survival	CACE analysis					
	CACE 1			CACE 2		
	Treatment arm, n/N (% of total)		OR (95% CI)	Treatment arm, n/N (% of total)		OR (95% CI)
LUCAS-2	Control	LUCAS-2		Control		
To 30 days	81/1241 (6.5)	153/2155 (7.1)	0.92 (0.69 to 1.21)	50/985 (5.1)	99/1710 (5.8)	0.87 (0.61 to 1.23)
With a CPC score of 1 or 2	62/1238 (5.0)	142/2151 (6.6)	0.76 (0.56 to 1.03)	38/983 (3.9)	101/1701 (5.9)	0.65 (0.45 to 0.96)
Survived event	297/779 (38.1)	527/1378 (38.2)	0.97 (0.84 to 1.18)	232/632 (36.7)	413/1077 (38.4)	0.96 (0.79 to 1.16)

(ambulance or RRV); whether or not the patient received bystander CPR; aetiology; and region (*Table 11*). In the subgroup analysis by initial rhythm, there was a difference in treatment effect between patients with a shockable initial rhythm and those with PEA or asystole. Survival was lower in the LUCAS-2 group than in those with shockable initial rhythms (OR 0.71, 95% CI 0.52 to 0.98), but higher in the PEA/asystole group (OR 1.38, 95% CI 0.80 to 2.36).

TABLE 11 Subgroup analyses for primary outcome (30-day survival)

Comparison	Subgroup	Treatment arm, n/N (% of total)			Test of interaction (p-value)
		LUCAS-2	Control	OR (95% CI)	
Initial rhythm	VF/VT	69/376 (18.4)	148/615 (24.1)	0.71 (0.52 to 0.98)	0.0390
	PEA/asystole	24/1222 (2.0)	30/2091 (1.4)	1.38 (0.80 to 2.36)	
	Rhythm not known	11/54 (20.4)	15/113 (13.3)	–	
Witnessed status	Witnessed	89/1001 (8.9)	163/1749 (9.3)	0.96 (0.73 to 1.25)	0.6105
	Not witnessed	10/528 (1.9)	21/864 (2.4)	0.78 (0.36 to 1.66)	
	Witnessed status not known	123 (7.4)	206 (7.3)	–	
Bystander CPR	Given	42/716 (5.9)	68/1238 (5.5)	1.07 (0.72 to 1.59)	0.3656
	Not given	59/846 (7.0)	115/1413 (8.1)	0.86 (0.61 to 1.17)	
	Not known	90	168	–	
Type of vehicle	Ambulance	60/1063 (5.6)	127/1773 (7.7)	0.78 (0.56 to 1.06)	0.0928
	Rapid response car	44/589 (7.5)	66/1045 (6.3)	1.20 (0.81 to 1.78)	
Region	A	16/186 (8.6)	23/357 (6.4)	1.37 (0.70 to 2.66)	0.5217
	B	9/149 (6.1)	33/359 (9.2)	0.64 (0.30 to 1.37)	
	C	19/346 (5.5)	22/352 (6.3)	0.87 (0.46 to 1.64)	
	D	60/972 (6.2)	115/1750 (6.6)	0.94 (0.68 to 1.29)	
Aetiology	Presumed cardiac	91/1417 (6.4)	173/2445 (7.1)	0.90 (0.69 to 1.17)	0.1287
	Other	9/130 (6.9)	7/198 (3.5)	2.03 (0.74 to 5.59)	

The analyses of age and response time using fractional polynomial models did not show any interaction effects of these variables with the treatment effect of the LUCAS-2 device. Therefore, we did not find any evidence that the treatment effect of the LUCAS-2 device differs depending on the age of the patient or ambulance service response time.

Serious adverse events

Seven clinical AEs were reported in the LUCAS-2 group (three events of chest bruising, two of chest laceration and two of blood in mouth). No SAEs were reported. Fifteen device incidents occurred during operational use (four incidents in which alarms sounded, seven in which the device stopped working and four other device incidents). No adverse or SAEs were reported in the control group.

Follow-up at 3 months and 12 months

We considered using multiple imputation (MI) to attempt to correct for the effects of missing data, but we felt that the assumptions of any imputation procedure were unlikely to hold, given the large number of missing data and the high probability that missingness was related to outcome. Analyses therefore used available cases only, with no imputation.

At the 3-month follow-up (Table 12), SF-12 mental and physical scores and EQ-5D quality-of-life scores were slightly lower in the LUCAS-2 group than in the control group.

In the 12-month follow-up (Table 13), all of the results were in the same direction, indicating worse outcomes in the LUCAS-2 group. For some of the outcomes, the 95% CIs excluded zero, whereas for others the data were compatible with a zero or small positive effect.

All of the follow-up results should be interpreted cautiously because of the low percentage of patients known to be alive who were included in the follow-up. This was caused by refusal of consent and non-response to the invitation to participate in the follow-up and led to high numbers of missing data, with a consequent risk of bias. It is possible that those who declined to take part and those who did not

TABLE 12 Outcome at 3 months for SF-12 and EQ-5D: higher scores indicate better outcomes

Outcome	Treatment arm		Difference (95% CI)	
	LUCAS-2 (N = 47)	Control (N = 99)	Unadjusted	Adjusted
SF-12 physical				
Mean score (SD)	38.9 (11.5)	41.7 (10.9)	-2.8 (-6.7 to 1.1)	-3.0 (-7.0 to 1.1)
Median score (IQR)	40.8 (32.1–48.0)	42.6 (34.7–49.4)		
Missing scores, n	2	2		
SF-12 mental				
Mean score (SD)	47.3 (13.4)	48.9 (10.5)	-1.6 (-5.6 to 2.5)	-1.5 (-5.5 to 2.6)
Median score (IQR)	51.7 (38.2–57.3)	50.2 (42.1–57.2)		
Missing scores, n	2	2		
EQ-5D				
Mean score (SD)	63.8 (23.5)	72.0 (18.0)	-8.2 (-15.1 to -1.3)	-6.8 (-13.7 to 0.1)
Median score (IQR)	65.0 (50.0–80.0)	75.0 (64.0–85.0)		
Missing scores, n	0	0		

Mean difference are adjusted for age, sex, rhythm, bystander CPR and response time.
IQR, interquartile range.

TABLE 13 Outcomes at 12 months. For SF-12, EQ-5D and MMSE higher scores indicate better outcomes. For PCL-C and HADS, lower scores indicate better outcomes

Outcome	Treatment arm		Difference (95% CI)	
	LUCAS-2 (N = 48)	Control (N = 95)	Unadjusted	Adjusted
SF-12 physical				
Mean score (SD)	40.1 (12.7)	43.8 (10.7)	-3.8 (-7.8 to 0.2)	-3.5 (-7.4 to 0.4)
Median score (IQR)	40.7 (30.8–51.0)	44.9 (36.1–52.5)		
Missing scores, n	1	2		
SF-12 mental				
Mean score (SD)	47.5 (11.5)	49.4 (11.8)	-1.8 (-5.9 to 2.3)	-1.5 (-5.5 to 2.5)
Median score (IQR)	48.9 (42.9–55.3)	50.8 (42.7–59.1)		
Missing scores, n	1	2		
EQ-5D				
Mean score (SD)	68.3 (22.0)	75.0 (17.4)	-6.7 (-13.3 to -0.1)	-6.4 (-13.1 to 0.3)
Median score (IQR)	72.0 (54.5–87.5)	80.0 (64.0–90.0)		
Missing scores, n	0	0		
MMSE				
Mean score (SD)	26.9 (3.7)	28.0 (2.3)	-1.1 (-2.2 to -0.1)	-1.5 (-2.6 to -0.4)
Median score (IQR)	28.0 (27.0–29.0)	29.0 (27.0–30.0)		
Missing scores, n	1	1		
HADS anxiety				
Mean score (SD)	6.7 (4.8)	5.7 (4.2)	0.9 (-0.6 to 2.5)	0.6 (-0.9 to 2.1)
Median score (IQR)	6.0 (3.0–10.0)	6.0 (2.0–8.0)		
Missing scores, n	0	0		
HADS depression				
Mean score (SD)	5.8 (4.4)	4.4 (3.5)	1.4 (0.1 to 2.8)	1.1 (-0.2 to 2.5)
Median score (IQR)	5.0 (2.0–9.0)	4.0 (1.0–7.0)		
Missing scores, n	0	0		
PCL-C				
Mean score (SD)	32.0 (12.9)	30.2 (11.0)	1.8 (-2.4 to 5.9)	1.6 (-2.6 to 5.7)
Median score (IQR)	28.0 (22.0–36.0)	28.0 (20.0–38.0)		
Missing scores, n	3	2		

IQR, interquartile range.

respond may have had worse outcomes than those who responded. Slightly fewer people were followed up in the LUCAS-2 group, which could have been as a result of worse outcomes in that group.

The results of the 'quality of CPR study' are shown in *Table 14*. Data recording problems in one ambulance service meant that only compression depth was analysable from this service, so data for both compression rate and compression fraction were available from only three services.

TABLE 14 Results of quality of CPR manikin study

Ambulance service	Number of personnel	Depth (mm), mean (SD)	Rate (compressions/minute), mean (SD)	Compression fraction, mean (SD)
A	155	49.4 (8.0)	131.8 (15.1)	65.5 (9.0)
B	157	45.0 (6.8)	119.4 (10.4)	65.4 (11.4)
C	73	41.0 (4.8)	117.6 (13.5)	65.9 (9.1)
D	103	48.6 (8.4)	^a	^a

^a Not estimable because of data errors.

Compression depth was fairly consistent across services, with the mean varying between 41 and 49.4 mm. Mean compression rate was substantially faster in one service than the other two that had data, and exceeded the guideline recommended rate of 120 compressions per minute. Compression fraction was very consistent across the three services that had data, at between 65% and 66%.

Chapter 4 Mechanical chest compression for out-of-hospital cardiac arrest: systematic review and meta-analysis

Introduction

At the time that the PARAMEDIC trial was initiated, we were aware of two other planned or ongoing trials of mechanical chest compression devices^{70,71} and two that had been published.^{32,72} These trials used either the LUCAS device (original version of the battery-powered LUCAS-2) or the AutoPulse (ZOLL Medical Corporation, Chelmsford, MA, USA), which uses a load-distributing band system. A wide band fits around the chest, and its circumference is alternately shortened and lengthened, providing rhythmic chest compressions.

The two other large RCTs have recently been reported.^{71,73} It is therefore useful to summarise the overall evidence for mechanical chest compression devices in OHCA in a systematic review and, where appropriate, meta-analysis.

Methods

Studies were eligible for inclusion if they were individually randomised or cluster randomised trials that compared the use of a mechanical chest compression device with standard manual chest compression in adult patients following OHCA. There was no restriction of eligibility based on language of publication. Quasi-randomised trials, for example those whose participants were randomised by birth date or days of the week, were excluded. Studies were not included in analyses if they reported insufficient information to allow assessment of their risk of bias. Screening, decisions about inclusion and data extraction were performed by one author and checked by a second author. The review protocol was not preregistered or published.

We searched electronic resources (MEDLINE, EMBASE and the Cochrane Central Register of Controlled Trials from 1990 to February 2015) and the reference lists of studies and review articles (last search February 2015). We based our search strategies on that published by the Cochrane review of mechanical chest compression devices,⁷⁴ which used a combination of search terms to describe the condition (cardiac arrest), the intervention (mechanical compression devices) and the study design (RCTs) (see *Appendix 9*).

For each eligible study, we extracted information about the study's population and methodology, and the following outcomes: ROSC; survived event (sustained ROSC until handover to a hospital emergency department); survival to hospital discharge or 30 days; and survival with good neurological outcome. Good neurological outcome was defined as either a CPC score of 1 or 2 or a mRS score of between 0 and 3.⁷⁵ When studies presented a treatment effect estimate that was adjusted for important covariates (e.g. clustering, initial rhythm, bystander CPR, EMS response time, age), we used this estimate in meta-analyses in preference to unadjusted results.

We used the Cochrane risk-of-bias tool to assess studies' risk of bias. This assesses seven domains: (1) generation of random allocation sequence; (2) allocation concealment; (3) blinding of participants and study personnel; (4) blinding of outcome assessment; (5) incomplete outcome data; (6) selective reporting; and (7) other sources of bias. For each study, we assessed the methods that were used to address each potential source of bias and summarised them in tabular form. We did not produce an overall bias risk judgement or score, but assessed each domain separately (*Table 15*).

TABLE 15 Characteristics of studies and risk-of-bias assessments

Study (trial acronym or first author) and year of study	Unit of randomisation	Study setting	Recruitment period	Intervention	Number of participants	Sequence generation	Allocation concealment	Blinding; patients and clinicians	Blinding; outcome assessment	Percentage of participants with missing data for each outcome	Selective reporting	Other sources of bias
ASPIRE, 2006 ⁷²	Cluster – crossover at predetermined intervals	USA/Canada	2004–5	AutoPulse	767; 51 clusters (EMS stations or groups of stations)	No information	Not concealed; ambulance staff aware of intervention	Not blinded	Unclear	Survival: 0% Survival with a CPC score of 1 or 2: 0.7%	No evidence	Participants with missing CPC scores were 8.3% of survivors
Smekal, 2011 ⁷²	Patient	Sweden	2005–7	LUCAS	148	No information	Sealed randomisation letter carried with device, opened at time of randomisation	Not blinded	Unclear	Survival: 0.7% ROSC: 1.4%	No evidence	<ul style="list-style-type: none"> Primary analysis included 767 primary cases, 304 non-primary cases and 306 with exclusion criteria excluded
LINC, 2014 ⁷⁰	Patient	Sweden, UK and the Netherlands	2008–12	LUCAS/ LUCAS-2	2589	No information	Sealed, opaque envelopes carried in ambulance and opened at the time of randomisation	Not blinded	Unclear	Survival: 1.1% ROSC: 0.1% Survived event: 0%	No evidence	Survival with a CPC score of 1 or 2: 1.1%

Study (trial acronym or first author) and year of study	Unit of randomisation	Study setting	Recruitment period	Intervention	Number of participants	Sequence generation	Allocation concealment	Blinding; patients and clinicians	Blinding; outcome assessment	Percentage of participants with missing data for each outcome	Selective reporting	Other sources of bias
CIRC, 2014 ⁷¹	Patient	Austria, the Netherlands and the USA	2009–11	AutoPulse	4231	No information	Sealed randomisation cards opened when indication for CPR was found	Not blinded	'Not always blinded'	Survival: 0.3% ROSC: 0% Survival with a mRS score of 0–3: 2.8%	No evidence	Participants with missing mRS scores were 27.7% of survivors
										<ul style="list-style-type: none"> 522 participants satisfying exclusion criteria excluded post randomisation Primary analysis excluded participants in 'run-in' phase and those recruited in early part of trial when battery issues led to poor compliance 		
PARAMEDIC, 2015 ⁷³	Cluster	UK	2010–13	LUCAS-2	4471; 418 clusters (vehicles)	Computer generated	Not concealed; ambulance staff aware of intervention	Not blinded	Survival from routine data Neurological status assessment blinded	Survival: 0% ROSC: 3.1% Survived event: 4.7% Survival with a CPC score of 1 or 2: 0.2%	No evidence	Participants with missing CPC score were 2.5% of survivors

LINC, LUCAS in Cardiac Arrest.

We combined studies using Review Manager software version 5.3 (RevMan, The Cochrane Collaboration, The Nordic Cochrane Centre, Copenhagen, Denmark). As there may be differences in treatment effect between trials, especially those using different devices, we used a random-effects model. We used the generic inverse variance method in RevMan to estimate the average treatment effect (OR) for each outcome, and the uncertainty around it, measured by the 95% CI. We also calculated 95% prediction intervals⁷⁶ to estimate the range of plausible treatment effects. We quantified heterogeneity in each analysis by the τ^2 -statistic and I^2 -statistic. Studies were subgrouped by the type of mechanical compression device that was used, as different devices operate in different ways and hence could have different treatment effects. Our primary analysis compared mechanical compression with manual compression, and we performed a subgroup analysis by type of device to explore whether or not there was any evidence that treatment effects differed between devices.

Some of the included trials presented several results using different adjustments for covariates and design elements. We performed sensitivity analyses to explore the effects of using differently adjusted results for these trials. In addition, the PARAMEDIC trial⁷¹ presented CACE estimates, to estimate the treatment effect in the presence of non-compliance.^{75,76} We performed additional sensitivity analyses to explore the effects of using these estimates.

Results

The search located five eligible studies^{55,67,69-71} (Figure 8).

Two trials^{55,69} evaluated the AutoPulse device and three trials^{67,70,71} evaluated the LUCAS device. Two of the studies^{55,71} used a cluster randomised design: one study (PARAMEDIC)⁷¹ randomising by ambulance service vehicles and the other study [AutoPulse Assisted Prehospital International Resuscitation (ASPIRE)]⁵⁵ using ambulance stations or groups of stations as the clusters; this study⁵⁵ also incorporated crossovers at prespecified points between the intervention and control groups. The other three studies^{67,69,70} utilised individual randomisation, using sealed envelopes or cards carried with the device, which were accessed by the paramedic at the time of the resuscitation attempt.

There were a number of differences between the studies in addition to the chest compression device used, which may have caused differences in treatment effects and hence introduced heterogeneity into the meta-analyses. In two studies,^{67,70} the LUCAS-2 device was used as part of a modified treatment algorithm, whereas in the third LUCAS-2 study,⁷¹ mechanical chest compression was simply used to replace manual compression in the standard algorithm. One of the trials of AutoPulse conducted extensive training to optimise the quality of manual CPR that was provided to the control group;⁷⁷ in contrast, other trials did

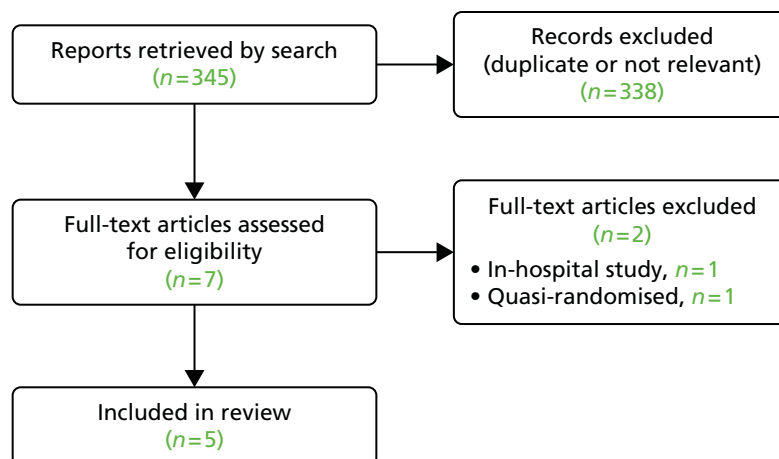

FIGURE 8 Flow chart of studies.

not provide extra training, but the control group received CPR as it would be provided in standard clinical practice.

The randomisation methods of the studies appeared to be adequate, although four studies did not provide any information on the generation of the random allocation sequence.^{55,67,69,70} One concern with individual randomisation was that it would be possible for ambulance staff to open randomisation envelopes early and subvert the randomisation scheme. No studies reported any problems with individual randomisation procedures, such as missing randomisation cards that could not be accounted for (which might indicate that crews had selected the intervention) or large numbers of eligible patients who were not recruited (which might suggest that the crew felt that the randomised allocation would not be good for the patient).

Blinding of clinicians providing care was clearly not possible and participants who survived may also have been aware of which allocation they had received. For example, use of the LUCAS-2 device may leave characteristic marks on the patient's chest. The assessment of survival outcomes was unlikely to have been affected by whether or not the people assessing the outcome were blinded. One study⁷¹ stated that personnel assessing neurological status (via the CPC or mRS) were blinded; in other studies, this was unclear. It is conceivable that knowledge of treatment allocations could influence assessments of neurological status; if assessors had strong views on the effectiveness of the intervention being tested, they may have adjusted their threshold for allocating a patient to a mRS or CPC category. We cannot exclude this potential bias in studies for which outcome assessment was not blinded.

In all of the trials, the proportion of missing outcome data was low, when measured as a percentage of all of the study participants. However, in some trials, there was potentially bias because of missing data in the assessment of neurologically intact survival. This was because the missing data were concentrated among survivors; for example, in the Circulation Improving Resuscitation Care (CIRC) trial,⁷¹ although only 2.8% of participants had missing mRS data, they represented 27.7% of survivors. The populations included varied between trials. In the ASPIRE study,⁵⁵ results were presented for a prespecified 'primary' population (patients who were in cardiac arrest at the time of EMS arrival and whose cardiac arrest was considered to be of cardiac origin). Patients who fulfilled exclusion criteria were treated according to trial allocation, but subsequently excluded (in order not to introduce delays to treatment); however, 304 'non-primary' cases were also excluded from the main results. In the CIRC trial,⁷¹ there were also 522 post-randomisation exclusions of patients fulfilling exclusion criteria. However, this trial⁶⁹ also excluded patients recruited in a prespecified run-in phase, an unspecified number of patients recruited early in the trial (after the run-in period) when compliance with AutoPulse was found to be poor as a result of battery issues and data from one site for a 3-month period when that site was non-compliant with the study protocol (number not stated).

The CIRC⁶⁹ trial used a group sequential design, with predefined stopping boundaries for superiority, inferiority and equivalence (double triangular test).^{77,78} The trial report presented treatment effect estimates that were adjusted for clinical covariates for all outcomes, but additionally adjusted the primary outcome (survival to hospital discharge) for the sequence of interim analyses. In this review we have used the results adjusted for covariates, but not for the interim analyses, because these are consistent and based on the data rather than the decision-making process. We explored the effect of the adjustment of the primary outcome for interim analyses with a sensitivity analysis.

The meta-analyses (see *Figures 9–12*) do not suggest an advantage to mechanical chest compression, using either device, for any of the outcomes. CIs and prediction intervals were wide, reflecting the low incidence of favourable outcomes after OHCA and consequent imprecision of treatment effect estimates.

For ROSC (*Figure 9*), although there was no evidence of an overall difference between mechanical and manual chest compression (average OR 0.96, 95% CI 0.85 to 1.10, 95% prediction interval 0.66 to 1.41), there was some evidence that the effects of the LUCAS-2 and AutoPulse devices were different ($I^2 = 78.5\%$ for subgroup differences). There were data from only one AutoPulse trial,⁶⁹ but that suggested a lower proportion achieving ROSC in the mechanical chest compression group.

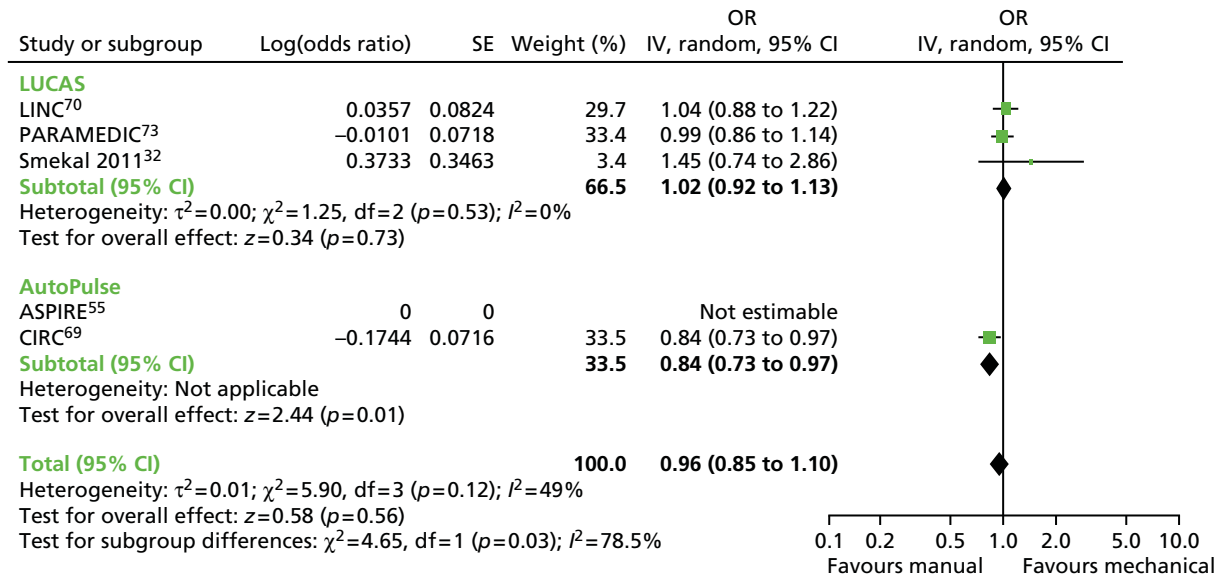

FIGURE 9 Return of spontaneous circulation. IV, inverse variance; SE, standard error.

Survival of event was reported only by trials that used the LUCAS-2 device (Figure 10). The results were consistent across trials and suggested no advantage to mechanical chest compression devices (OR 0.95, 95% CI 0.85 to 1.07; 95% prediction interval 0.45 to 2.00).

The analysis of survival to discharge or 30 days (Figure 11) again suggested no advantage to mechanical chest compression (OR 0.89, 95% CI 0.77 to 1.02; 95% prediction interval 0.71 to 1.12). The point estimate was in the direction of favouring manual chest compression and the upper 95% confidence limit was only just > 1. There was no evidence of heterogeneity of treatment effects. A sensitivity analysis using the estimate for the CIRC trial,⁷¹ adjusted for interim analyses as well as covariates, did not make a major difference to the overall average treatment effect (OR 0.94, 95% CI 0.79 to 1.11; 95% prediction interval 0.62 to 1.43). Similarly, sensitivity analyses using the CACE estimates for the PARAMEDIC trial⁷¹ did not make a substantial difference to the overall result.

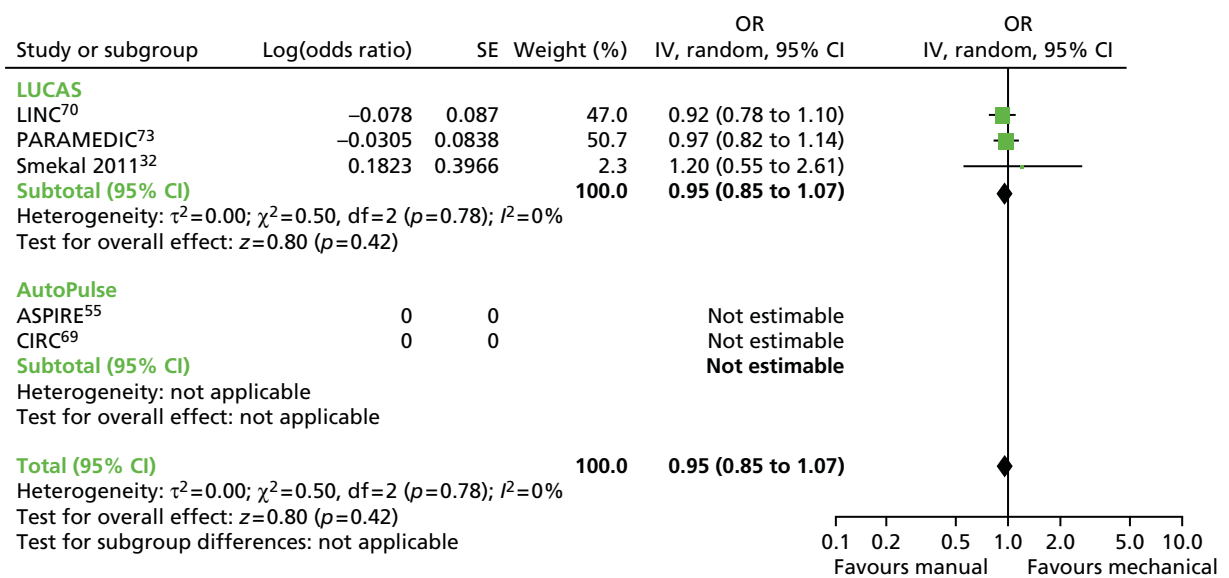

FIGURE 10 Survived event (i.e. sustained ROSC to handover to hospital emergency department). IV, inverse variance.

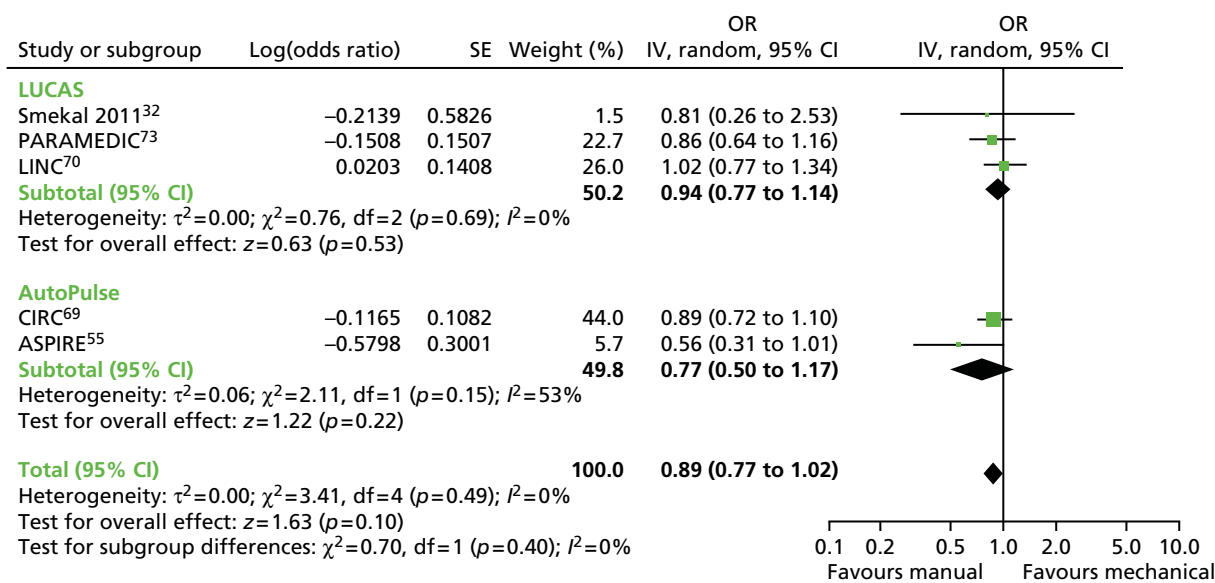

FIGURE 11 Survival to discharge from hospital or 30 days. IV, inverse variance.

Results for survival with good neurological outcome (Figure 12) were more heterogeneous than for other outcomes ($I^2 = 68\%$). This was not due to differences between the LUCAS-2 and AutoPulse devices, which were small ($I^2 = 11\%$ for subgroup differences), but to inconsistency between the results of the two trials of each device. Reasons for the inconsistency were unclear. Overall, there was no evidence that the average treatment effect favoured mechanical chest compression, but the 95% prediction interval was very wide (OR 0.76, 95% CI 0.53 to 1.11; 95% prediction interval 0.17 to 3.49).

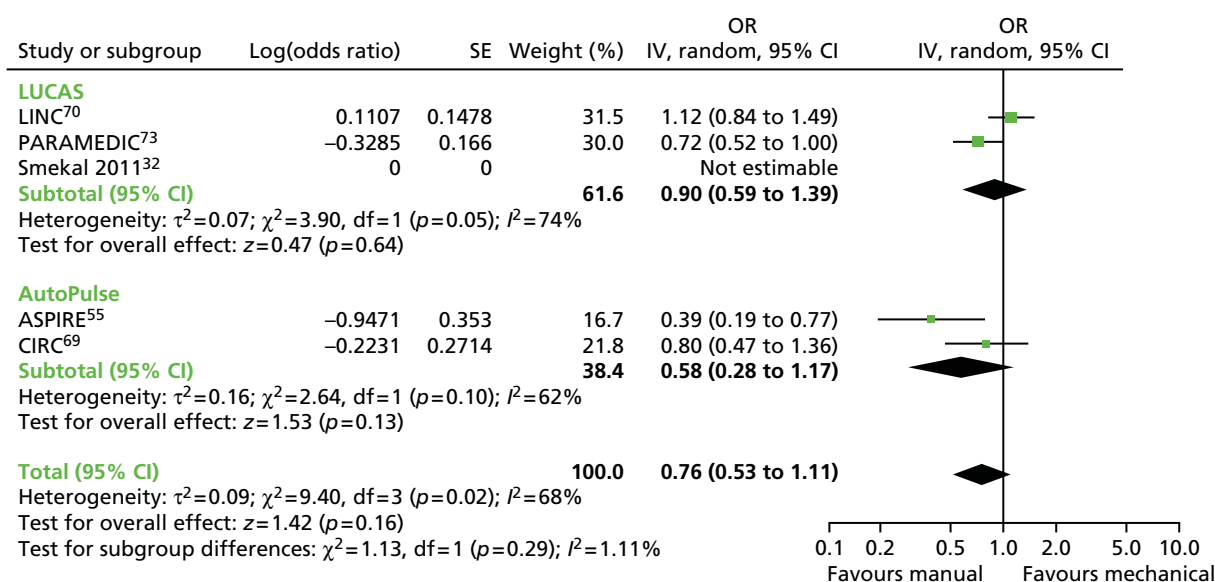

FIGURE 12 Survival with CPC score of 1–2 or mRS score of 0–3. IV, inverse variance.

Discussion

The trials recruited unselected populations of patients, which were typical of clinical practice in the geographical areas in which they were conducted. Despite the large size of many of the trials included in the review, CIs around the combined treatment effect estimates were relatively wide because of the low survival rate from OHCA. The methodological quality of the included studies was generally good. Secure methods of randomisation were used and for most outcomes there were few missing data. Trials using a cluster randomised design were unable to conceal allocations in advance of assignment and ambulance crews would have been aware of the allocation. This could have led to inclusion bias, in two ways. First, patients might not be reported to the trial if it was felt that they were not receiving the best allocation. The PARAMEDIC trial⁷¹ guarded against this by including all eligible cardiac arrests that were attended by trial vehicles. It was not clear whether or not this was also the case in the ASPIRE study.⁵⁵ Second, the threshold for initiating a resuscitation attempt could have varied according to the intervention. For example, if a crew believed strongly that mechanical chest compression was better, they might initiate a resuscitation attempt in a situation in which they would not attempt resuscitation if manual chest compression was to be used. In the PARAMEDIC trial,⁷¹ the DMC reviewed evidence for differential thresholds for resuscitation but did not find evidence of any appreciable selection bias.

The use of the double triangular test design in the CIRC⁶⁹ trial raises a number of issues. The adjustment of the final analysis to allow for the interim analyses had a large effect on the primary outcome (survival to hospital discharge), changing the point estimate of the OR from 0.89 to 1.06. The secondary analyses were not adjusted for the interim analyses, so the results for the primary and secondary outcomes were not directly comparable. In addition, the boundaries for equivalence in the double triangular test were very generous; if the 'equivalence' boundary was crossed, the 95% CI would be contained between log odds of -0.37 and 0.37 (i.e. an OR of 0.69 and 1.45).⁶⁹ This interval includes values that would represent substantial benefit and substantial harm, so the conclusion of 'equivalence' in this situation is questionable.

In some trials, data for neurologically intact survival were missing for a high proportion of survivors. This was most severe in the CIRC trial,⁷¹ in which data for this outcome were lacking for 27.7% of survivors. This reflects the difficulty of performing follow-up assessments on cardiac arrest survivors, but clearly has the potential to introduce bias. It is possible, or even likely, that there could be an association between missingness and neurological outcome. There are many plausible reasons why patients with poor outcomes may be more likely to be lost; for example, they may be harder to contact because they have moved to a residential care facility or they may be less willing or able to undertake follow-up assessments.

Chapter 5 Economic evaluation

Introduction

The economic evaluation was conducted to assess the cost-effectiveness of use of the LUCAS-2 device compared with manual chest compression (manual CPR) during resuscitation by ambulance staff after OHCA. The economic evaluation consisted of two distinct, but complementary, sets of analyses: a within-trial analysis over the 12-month trial period and a decision-analytic model that was constructed to extrapolate the results over the expected lifetime of the trial participants. The analyses were conducted from the NHS and Personal Social Services (PSS) perspective and they report cost per incremental quality-adjusted life-year (QALY) of the LUCAS-2 device compared with usual care (manual CPR). The analyses were conducted in line with best practice guidelines.⁷⁹

Methods

Within-trial analysis

The within-trial analysis aimed to determine the cost-effectiveness of the LUCAS-2 device compared with manual chest compression over the period of the trial (i.e. from cardiac arrest to 12 months' follow-up). The analysis used QALYs as the main outcome and adopted the perspective of the NHS and PSS. Utility values were derived from patient questionnaires; resource use was obtained from a variety of sources, including the trial CRFs, large data sets (i.e. HES, ICNARC) and self-completed patient questionnaires. Neither costs nor QALYs were discounted given the 12-month time period. The results are reported as incremental cost-effectiveness ratios (ICERs).

Quality-adjusted life-years

Quality-adjusted life-years reflect both duration and quality of life and their estimation requires the production of utility weights for each health state observed in the trial population. HRQL was assessed using the EQ-5D,⁴² which has been validated for use in the critical care patient group.⁸⁰ Surviving patients completed the EQ-5D at 3 and 12 months post cardiac arrest. The EQ-5D responses were converted to health-state utility values using the UK tariff.⁸¹ Utility values were combined with survival information to calculate QALYs for the trial period using an area under the curve (AUC) approach. As patients were unable to complete the measure at baseline, estimates had to be made of their baseline utility level. Following strategies previously used in studies that have dealt with this scenario,⁸²⁻⁸⁴ we assumed that patients who experienced a cardiac arrest had a baseline utility value of '0' (which is equivalent to dead). We then assumed a linear transition from '0' to the 3-month utility value and, similarly, from the 3- to the 12-month utility value. A utility weight of zero was assigned to patients who died within 3 months, which may underestimate total QALYs. We explored an alternative assumption in the sensitivity analysis, for which the survival days of these patients were assigned the average 3-month utility estimated in our sample.

Resource use and costs

The costs considered in this analysis included intervention costs (i.e. cost of the LUCAS-2 device and ambulance costs), costs of hospital inpatient stays, accident and emergency (A&E) admissions and outpatient visits and the use of primary care and community-based health and social care services (such as GP and social worker visits).

Resource use data were collected prospectively and retrospectively. Hospital resource utilisation was obtained through linkage with the HES data set. We extracted data from the HES for study participants

from cardiac arrest to 12 months after randomisation. The data set records information on the total number of days in hospital, the number of in-person and telephone outpatient visits and the number of A&E admissions. To identify the number of hospital days spent in the ICU (*Table 16*) we used information from the ICNARC data set. Patients who stayed for < 24 hours in hospital were also identified. Some of these were regular admissions and, based on the profile of their procedural use, were assigned the cost of 1 day in ICU. Another group of patients who stayed for < 24 hours in hospital were recorded in HES as day case or regular day admissions. Hospital costs were obtained by multiplying the number of days or visits of each service by the corresponding unit cost derived from NHS reference costs databases.⁸⁵

Following hospital discharge, health-care resource use questionnaires were completed by surviving patients at 3 and 12 months post cardiac arrest. Patients were asked about their use of health and social services during the previous 3 months, including further inpatient and outpatient care and primary and community-based health and social services. For the 6-month period during which non-hospital resource use data were not collected (between 3 and 9 months post cardiac arrest), we used the average resource utilisation between the initial (0–3 months) and final (9–12 months) period. Patients who died within 3 months were assumed to have incurred no community-based health and social care costs. Health-care resource use was multiplied by the relevant unit costs extracted from the national reference costs (*Table 17*).⁸⁶

A microcosting study was undertaken to establish the cost of the LUCAS-2 device and determine the relevant cost per application. This included (1) the cost of purchasing the device and accessories; (2) the cost of fitting the device to the ambulance; (3) maintenance costs; and (4) initial and ongoing staff training costs. The frequency of use observed in the trial was used to estimate the expected number of applications in order to calculate the expected cost per application (*Table 18*).

Missing data

The primary analysis used MI to handle missing data using baseline characteristics (sex and age) to impute missing follow-up HRQL and resource use information. Unlike more simple imputation approaches, MI reflects both the structural uncertainty related to the parameters of the imputation model and the uncertainty arising from missing data. Practically, to obtain total costs and QALYs at 1 year for each patient, missing data on HRQL and resource use were addressed using chained equations. We used truncated models to reflect the specific distribution of HRQL and resource use and generated 10 data sets. Estimates from each imputed data set were combined following Rubin's rule.⁸⁷ In the sensitivity analysis, we also report results from the complete-case analysis, which included only patients with non-missing utility values.

Cost-effectiveness analysis

The main cost-effectiveness outcome is the 1-year cost per QALY. ICERs were calculated where one intervention was more expensive and more effective or less effective and cheaper than the other.⁸⁸

TABLE 16 Summary table of ICU length-of-stay data

Patient group	<i>n</i>	Missing	ICU length of stay (days) mean (SD)	Source
Survived 1–30 days	588	–	3.15 (3.8)	ICNARC data and assumption ^a
Survived > 30 days	211	87	7.10 (17.6)	ICNARC data

a ICU length of stay from ICNARC was available for 296 patients who survived 1–30 days. Most patients in this group survived 1 or 2 days (62%) and spent their entire survival days in ICU. Patients in this group with missing ICNARC information were therefore assumed to have spent their entire survival period in the ICU.

TABLE 17 Unit costs used in the analysis

Resource item	Unit cost (£)	Source	Details/assumptions
LUCAS device cost per application	232	Own calculations: see <i>Table 18</i>	A lifespan of 8 years was assumed
Ambulance cost	180	<i>NHS Reference Costs 2013–14</i> ⁸⁵	'See and treat' (if died on scene)
	231	<i>NHS Reference Costs 2013–14</i> ⁸⁵	'See and treat and convey' (if did not die on scene)
Hospital-based or residential care services			
ICU per day	1382	<i>NHS Reference Costs 2013–14</i> ⁸⁵	Non-specific general adult critical care patients predominate Average cost of 0–6 or more organs supported: SC, CCU01; CC, XC01Z-XC07Z
Hospital inpatient stay per day	275	<i>NHS Reference Costs 2013–14</i> ⁸⁵	Non-elective inpatients; excess bed-days
Hospital outpatient clinic appointment	128	<i>NHS Reference Costs 2013–14</i> ⁸⁵	Outpatient/consultant led
Hospital A&E visit	339	<i>NHS Reference Costs 2013–14</i> ⁸⁵	Emergency medicine, category 3 investigation with category 4 treatment: SC, T01A; CC, VB02ZZ
Nursing/residential home per day	157	Curtis, 2012 ⁸⁶	Local authority residential care for older people Establishment cost per permanent resident week/7 days
Primary care and community-based health and social services			
GP: surgery visit	46	Curtis, 2012 ⁸⁶	Per-patient contact lasting 11.7 minutes, including direct care staff costs
GP: home visit	92	Curtis, 2012 ⁸⁶	(Per-patient contact lasting 11.7 minutes plus 12 minutes of travel time) × £3.90/minute cost of patient contact
District nurse/health visitor visit	45	<i>NHS Reference Costs 2013–14</i> ⁸⁵	Average of district nurse, face to face: SC, NURS; CC, N02AF Average of health visitor, face to face: SC, HVM; CC, N03G
Social worker visit	79	Curtis, 2012 ⁸⁶	One-hour appointment
Counsellor appointment	50	Curtis, 2012 ⁸⁶	One-hour appointment
Home help session	24	Curtis, 2012 ⁸⁶	One-hour weekday session
Speech and language therapist appointment	84	<i>NHS Reference Costs 2013–14</i> ⁸⁵	Speech and language therapist, adult, one to one: CC, A13A1
Psychologist appointment	85	<i>NHS Reference Costs 2013–14</i> ⁸⁵	Non-admitted non-face to face attendance, follow-up: SC, 656; CC, WF01C
Day centre visit	42	Curtis, 2012 ⁸⁶	Local authority day care for older people; per client session lasting 3.5 hours
Lunch or social club session	7	Curtis, 2012 ⁸⁶	Same cost as 1 hour of befriending older adults programme
Meals on Wheels	7	Curtis, 2012 ⁸⁶	Assuming one contact = one meal. Average cost of per 'meal on wheels' for the local authority
Family Support session	50	Curtis, 2012 ⁸⁶	Family support worker; per hour of client-related work
NHS codes: CC, currency code; SC, service code.			

TABLE 18 Cost of the LUCAS-2 device

Cost item	Assumptions	Cost (£) for the trial period
Purchase cost (LUCAS-2 and accessories)	A one-off purchase cost, the LUCAS-2 device and necessary accessories were calculated using the purchase cost for the device itself, suction cups, battery, 12-V car cable and power supply for inside the ambulance. The cost of each these items was multiplied by the number of ambulances in the intervention trial arm. Battery chargers and a spare battery at each of the 90 stations with the LUCAS-2 device were costed. For spare LUCAS-2 parts it was assumed that one set of each spare would be required per 10 devices. Spare parts included a carry bag, stabilisation strap and patient straps	148,504
Cost of fitting LUCAS-2 to vehicles	The total cost of fitting the device to ambulance vehicles required the cost of screws, chair strap, clips and net. One hour of labour was estimated to fit the strap per ambulance. The cost of fitting the device to one ambulance was then multiplied by the number of vehicles in the intervention arm	783
Maintenance (assuming no repairs)	The planned preventative maintenance service was estimated to cost £250 for each LUCAS-2 device. This cost assumed no parts were needed and no repairs occurred	35,750
Staff training (initial and ongoing)	Initial staff training: it was estimated that each regional ambulance trust had a mandatory training programme that paid paramedics 3 hours of overtime to attend. The per-paramedic cost was multiplied by the number of staff at each site who had been trained Ongoing staff training: one regional ambulance site reported a 30-minute training refresher for paramedics. It was assumed that paramedics in all sites would receive a similar 30-minute refresher course once per year. The cost per paramedic was multiplied by the total number of staff trained within the initial staff training	46,450
Total costs		231,488
Number of applications		996
Cost per application		232

The ICER is calculated by dividing the difference in mean cost between the two arms by the difference in mean QALYs between the two arms:

$$ICER = \frac{C_i - C_c}{E_i - E_c} = \frac{\Delta C}{\Delta E}, \quad (1)$$

where C_i and E_i are the cost and effectiveness of the LUCAS-2 device and C_c and E_c are the cost and effectiveness of manual compression, and ΔC and ΔE are the incremental cost and effect of the intervention compared with the comparator. Thus, the ICER represents the cost per QALY gained. ICERs below the NICE willingness-to-pay threshold (λ) of £20,000 are considered to indicate cost-effectiveness. For the main analyses, as effects were observed within 12 months, no discounting of costs or effects was required. ITT analyses were conducted throughout.

Uncertainty and sensitivity analysis

Uncertainty was explored by conducting non-parametric bootstrapping via 1000 resampled analyses. Cost-effectiveness planes (scatterplots of the 1000 bootstrap replications) were created.^{89,90} Sensitivity analyses were conducted to determine the impact of assumptions on the cost-effectiveness results. We compared results from complete-case analysis against MI and also carried out analyses using an average group cost for outliers with high costs. Owing to the large number of non-compliers, results of a

per-protocol analysis were also reported. We also derived net monetary benefits (NMBs) for each patient using the following:

$$\text{NMB} = \Delta E\lambda - \Delta C. \quad (2)$$

We then estimated linear regression models to identify predictors of NMB, including treatment arm.

Long-term decision-analytic model

To assess cost-effectiveness over the lifetime horizon, a decision tree combined with a Markov model was constructed⁹¹ (Figure 13). The model starts with a decision tree reflecting patients' risk of death at different time points and patient CPC score at the end of the trial. The end points of the decision tree are the starting point of the lifetime Markov model. We chose to model the intervention impact from baseline application rather than simply extending outcomes and costs from 12 months onwards. The main motivation for this was to enable better capture of uncertainty during the trial period and allow propagation of this through the lifetime horizon. Beyond 1 year post cardiac arrest, costs, HRQL and survival were modelled in two subsets of patients: patients with (1) good neurological outcomes at 1 year (CPC score of 1 or 2) and (2) poor neurological outcomes at 1 year (CPC score of >2). Relevant model parameters were extracted from the trial data and from the literature (Table 19). The parameters of interest included relative survival rates in these subgroups that were applied to UK reference mortality rates published by the Office for National Statistics (ONS) and annual cost and HRQL data for cardiac arrest survivors with/without good neurological outcomes (from trial data). Annual costs for patients with poor neurological outcomes were obtained from trial data

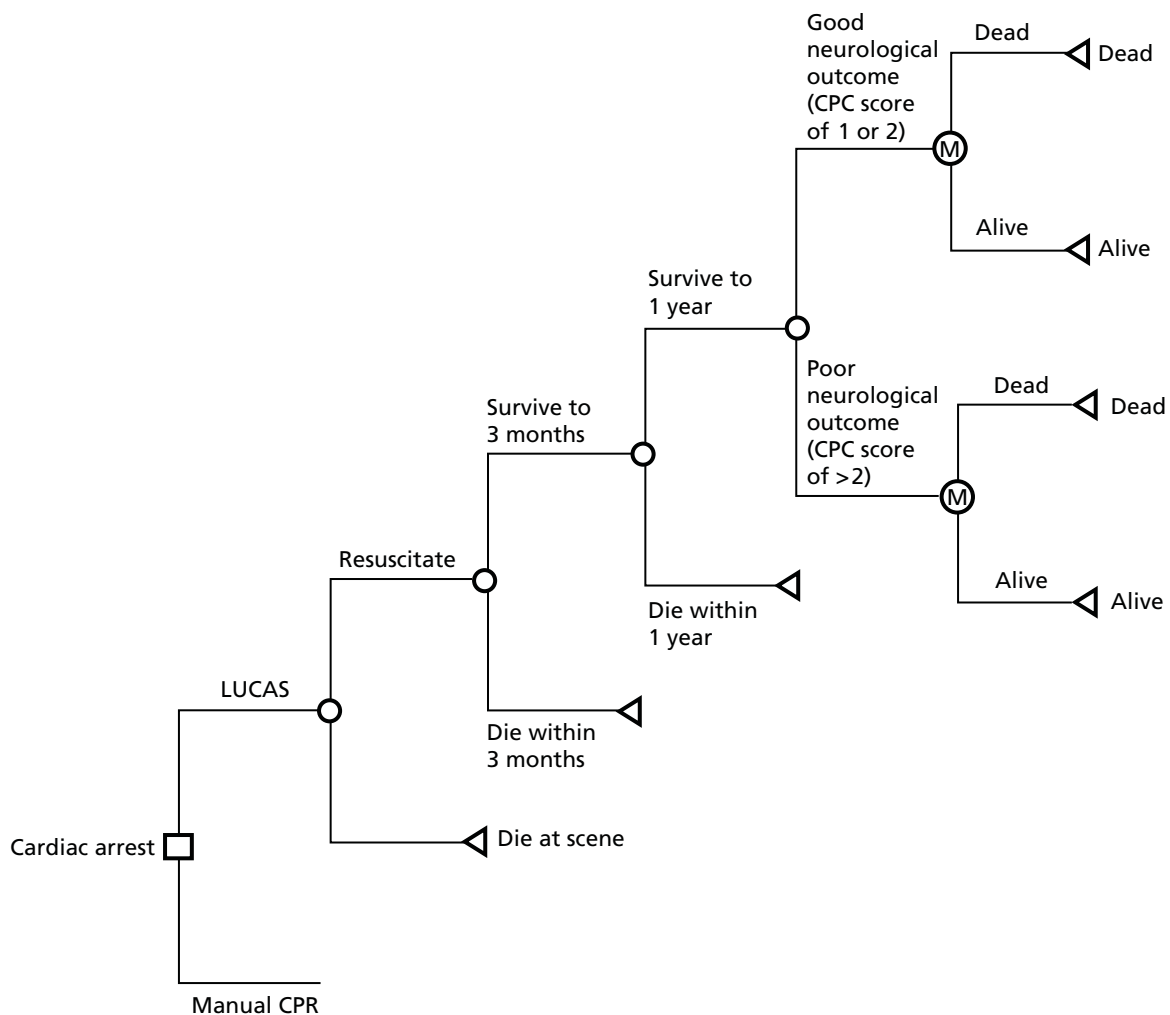

FIGURE 13 Structure of the decision-analytic model.

TABLE 19 Model parameters

Parameters	Group/arm	Mean value	Distribution	Source
Decision tree				
p (die on scene)	Manual CPR	0.3274	Beta	Trial data
	LUCAS-2	0.3290		
p (die within 3 months I did not die on scene)	Manual CPR	0.9029	Beta	Trial data
	LUCAS-2	0.9134		
p (die within 3–12 months I survived to 3 months)	Manual CPR	0.0380	Beta	Trial data
	LUCAS-2	0.0729		
p (good neurological outcome I survive to 1 year)	Manual CPR	0.8605	Beta	Trial data
	LUCAS-2	0.7442		
Markov model				
Annual mortality rate			Fixed	ONS ⁹²
Excess mortality for patients with poor neurological outcomes		1.67	Log-normal	Phelps 2013 ⁹³
Discount rate		3.5%	Fixed	
Annual cost (£)	Good neurological outcome (CPC score of 1 or 2)	3315	Log-normal	Trial data
	Poor neurological outcome (CPC score of 3 or 4)	43146	Log-normal	Trial data and Curtis, 2012 ⁸⁶
Utility	Good neurological outcome (CPC score of 1 or 2)	0.75	Beta	Trial data
	Poor neurological outcome (CPC score of 3 or 4)	0.47	Beta	Trial data

(outpatient visits and community-based health and social care) and residential care costs were added, as these patients are likely to require daily support/institutionalisation.⁸⁶

A discount rate of 3.5% was applied to costs and effects in the Markov model (see *Figure 13*). The within-trial analysis was conducted using the statistical software Stata version 13.1 (StataCorp LP, College Station, TX, USA) and the decision-analytic model was built using Microsoft Excel® (Microsoft Corporation, Redmond, WA, USA).

Cost-effectiveness analysis

The ICER is calculated by dividing the difference in mean cost between the two arms by the difference in mean QALYs between the two arms:

$$ICER = \frac{C_i - C_c}{E_i - E_c} = \frac{\Delta C}{\Delta E}, \quad (3)$$

where C_i and E_i are the expected cost and effectiveness of the LUCAS-2 device and are the expected cost and effectiveness of manual compression, and ΔC and ΔE are the incremental cost and effect of the intervention compared with the comparator. Thus, the ICER represents the cost per QALY gained. ICERs that are below the NICE willingness-to-pay threshold (λ) of £20,000 are considered to indicate cost-effectiveness. A discount rate of 3.5% was used to discount costs and benefits.

Uncertainty and sensitivity analysis

We first performed several one-way sensitivity analyses by adding and subtracting 20% of the main parameters of the model (i.e. costs, QALY and 1-year mortality) and assessed the subsequent impact on the ICERs. The value of 20% is arbitrary, but was considered likely to represent any uncertainty that might exist in parameter values. A probabilistic sensitivity analysis was then conducted for a more comprehensive account of uncertainty in the model parameters. Cost-effectiveness acceptability curves (CEACs) that show the probability of cost-effectiveness across a range of values for λ were created using the net benefit approach.⁹⁴ With this transformation, we avoid problems encountered with ICERs (same sign but opposite quadrants) and CEACs are much simpler to calculate.⁹⁵

Results

Among the 4771 patients who were enrolled in the study, 1652 were assigned to the intervention arm (LUCAS-2) and 2819 were assigned to the control group (manual CPR). During the trial, 985 (60%) patients in the intervention group received LUCAS-2 device treatment and 11 (< 1%) patients in the control group received mechanical CPR.⁷³ At 3 months, 96 (6%) patients survived in the LUCAS-2 group and 182 (6%) survived in the control group. At 12 months, 89 (5%) patients survived in the LUCAS-2 group and 177 (6%) survived in the manual CPR group (*Table 20*).

One-year costs

Using the complete-case analysis, the average cost at 1 year in the LUCAS-2 group was higher than in the manual CPR group, with an incremental cost of £106.70, with hospital costs being the main cost driver (*Table 21*). Overall, the average cost in each category of costs is higher in the LUCAS-2 group than in the manual CPR group.

We also observed higher costs in the LUCAS-2 arm than in the manual CPR arm in all cost categories in analyses that followed MI. Using the imputed data sets, we computed the total cost incurred in each patient group (the sum of all costs across all patients) that we divided by the number of 1-year survivors in each group (i.e. 177 patients in the manual CPR arm and 89 patients in the LUCAS-2 arm). We obtained a costs per 1-year survivor of £32,192 in the manual CPR arm and of £52,548 in the LUCAS-2 arm.

Quality of life

The mean utility scores in each group were measured at 3 and 12 months (*Table 22*). At both 3 and 12 months, HRQL was higher in the manual CPR group than in the LUCAS-2 group. An independent-sample *t*-test indicated that these differences were statistically significant. Changes in HRQL between the 3- and 12-month assessments were not statistically significant. *Table 22* also reports the average QALY over 1 year accrued by all patients in both groups based on the AUC calculations. The mean 1-year QALY is small as a

TABLE 20 Completion rate of HRQL and resource questionnaires

Follow-up	Treatment arm, n (%)	
	Manual CPR	LUCAS-2
3 months		
EQ-5D	99 (54)	47 (49)
Resource use	99 (54)	46 (48)
12 months		
EQ-5D	95 (54)	48 (54)
Resource use	93 (53)	46 (52)

TABLE 21 One-year costs

Arm	N	n missing	Mean (£)	Bootstrap 95% CI (£)	Minimum (£)	Maximum (£)
Complete-case data						
<i>Costs to the NHS over 1 year</i>						
Manual CPR	2690	129	1294.00	1152.40 to 1435.70	0	41,945
LUCAS-2	1577	75	1400.70	1131.20 to 1670.30	0	123,660
<i>ICU costs</i>						
Manual CPR	2762	57	959.20	826.80 to 1091.60	0	59,426
LUCAS-2	1622	30	1221.80	766.20 to 1677.50	0	317,860
<i>Other hospital costs (A&E, outpatient, general ward)</i>						
Manual CPR	2772	47	521.50	428.60 to 614.30	0	75,767
LUCAS-2	1619	33	585.00	386.00 to 784.00	0	74,276
<i>Hospital costs</i>						
Manual CPR	2732	87	1318.00	1136.30 to 1499.80	0	101,928
LUCAS-2	1599	53	1540.30	1083.40 to 1997.20	0	318,327
<i>Community-based health and social care costs</i>						
Manual CPR	2716	103	31.90	23.10 to 40.60	0	8834
LUCAS-2	1593	59	91.10	21.20 to 160.90	0	50,138
Imputed data						
<i>Costs to the NHS over 1 year</i>						
Manual CPR	2819	–	2021.30	1772.30 to 2270.20	0	41,945
LUCAS-2	1652	–	2831.00	2149.60 to 3512.30	0	123,660
<i>ICU costs</i>						
Manual CPR	2819	–	1102.10	947.00 to 1257.20	0	59,426
LUCAS-2	1652	–	1447.30	883.40 to 2011.10	0	317,860
<i>Other hospital costs (A&E, outpatients, general ward)</i>						
Manual CPR	2819	–	604.00	478.80 to 729.10	0	75,767
LUCAS-2	1652	–	724.60	507.50 to 941.70	0	74,276
<i>Hospital costs</i>						
Manual CPR	2819	–	1706.10	1477.50 to 1934.60	0	101,928
LUCAS-2	1652	–	2171.80	1525.60 to 2818.00	0	318,327
<i>Community-based health and social care costs</i>						
Manual CPR	2819	–	108.80	37.90 to 179.60	0	8834
LUCAS-2	1652	–	287.40	111.80 to 463.00	0	50,138
<i>Total costs to the NHS divided by the number of 1-year survivors</i>						
Manual CPR	177	–	32,192	28,228 to 36,156		
LUCAS-2	89	–	52,548	39,908 to 65,188		

TABLE 22 Health-related quality of life by treatment arm

Outcome	Treatment arm					
	Manual CPR			LUCAS-2		
	Number of participants with data	Mean	95% CI	Number of participants with data	Mean	95% CI
Utility score among survivors						
3 months	99	0.780	0.732 to 0.828	47	0.647	0.555 to 0.738
12 months	95	0.761	0.712 to 0.810	48	0.639	0.542 to 0.736
QALY over 12 months						
Complete case	2741	0.026	0.021 to 0.031	1609	0.018	0.013 to 0.024
Imputed	2818	0.042	0.036 to 0.048	1652	0.033	0.026 to 0.040

result of the high 1-year mortality rate in the sample (> 95%). We observe a small difference in mean QALY over 1 year (0.007), with patients in the manual CPR group having a higher average QALY than patients in the LUCAS-2 group. HRQL of survivors at 12 months was also estimated by neurological outcome status (as measured via the CPC score). We found a significant difference in HRQL between patients with good neurological outcome (CPC score of 1 or 2; mean 0.75) and patients with poor neurological outcome (CPC score of 3 or 4; mean: 0.47).

Cost-effectiveness at 1 year

Table 23 presents the cost-effectiveness results, showing the incremental costs and QALY for each arm of the trial, as well as the corresponding ICER. Results are shown for both the ITT and per-protocol analyses and, in each case, complete-case and MI results are presented. In addition, to obtain an approximation of the CACE, which was conducted for clinical outcomes, we inflate the ITT results using the proportion of compliers in the sample (i.e. 60%).

At 1 year, we found an incremental QALY of -0.0072 and an incremental cost of £106.70, which indicates that the LUCAS-2 device is dominated by manual chest compression, that is, the LUCAS-2 device is more costly and less effective than manual chest compression. When a per-protocol analysis was conducted instead, manual compression still dominated and results from the MI led to the same conclusion. The conclusions

TABLE 23 Incremental cost-effectiveness ratios

Analysis	Number of participants	Incremental		
		Cost (£)	QALY	ICER
MI (ITT)	4771	809.60	-0.0093	Manual CPR dominates
Complete case (ITT)	4267	106.70	-0.0072	
Complete case (ITT, average group cost for outliers)	4267	39.20	-0.0067	
MI (per protocol)	3793	495.90	-0.0142	
Complete case (per protocol)	3391	296.40	-0.0070	
Alternative QALY calculation ^a	4771	809.60	-0.0091	
QALY derived with SF-12 (complete case)	4267	106.70	-0.0046	
CACE (complete case)	4267	177.80	-0.012	

^a Instead of incurring no QALYs, patients who died within 3 months were imputed QALYs based on their total number of survival days, to which a utility was assigned corresponding to the average 3-month utility in our sample.

remain unchanged when QALYs were derived using SF-12 instead of EQ-5D. Overall, the results suggest that manual chest compression dominated the LUCAS-2 device, with the LUCAS-2 device having higher costs and providing lower QALY benefits than manual CPR. Interpretation, however, should be tempered by the very small between-group differences observed in QALYs and the relatively small differences in costs.

In *Figures 14 and 15*, we present the results of the 1000 bootstrap replications in the cost-effectiveness plane for both the complete-case analysis and the analysis based on MI. In both cases, the 1000 estimates are spread mainly in the north-west quadrant of the cost-effectiveness plane, meaning that the LUCAS-2 device is more costly and less effective than manual chest compression; however, it is worth noting that QALY losses are minimal. In other words, these results confirm the finding that the LUCAS-2 device is dominated by manual CPR. None of the iterations is below conventional values of the threshold (£20,000 per QALY). It is worth noting that the iterations in the MI analysis are more concentrated in the north-west quadrant (i.e. only a small number of iterations correspond to a decrease in costs). This suggests that the complete-case analysis may underestimate the incremental costs of the LUCAS-2 device. A possible explanation is that data of more costly (e.g. older) patients are more likely to be missing.

Net monetary benefits

Linear regression models using age, sex and treatment allocation as covariates and independent variables were run to predict NMBs. Treatment allocation was found to be a significant predictor of NMB; NMB was significantly smaller (more negative) in the LUCAS-2 group.

Long-term cost-effectiveness (Markov model)

The cost-effectiveness estimates were extrapolated over a lifetime time horizon using the Markov model. The lifetime cost-effectiveness results obtained with the model are presented in *Table 24*. The base-case analysis is based on a cohort of patients aged 60 years, followed over 40 years, which corresponds to the average age of patients who survived at 1 year. Results suggest that the LUCAS-2 device is dominated by manual CPR, with an incremental cost of £2376.40 and an incremental QALY of -0.1286 . This finding is robust to a range of sensitivity analyses as shown in *Table 24*.

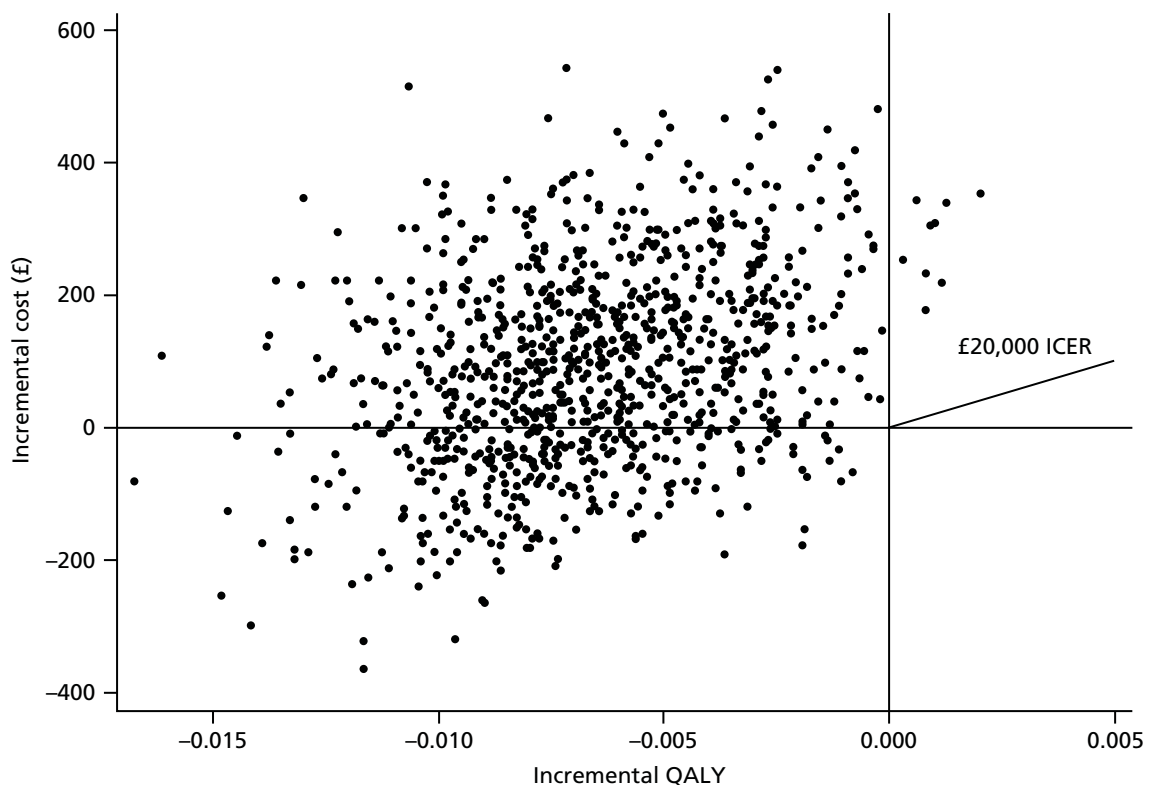

FIGURE 14 Cost-effectiveness plane for the LUCAS-2 device compared with manual chest compression. Complete-case analysis based on 1000 bootstrap replications.

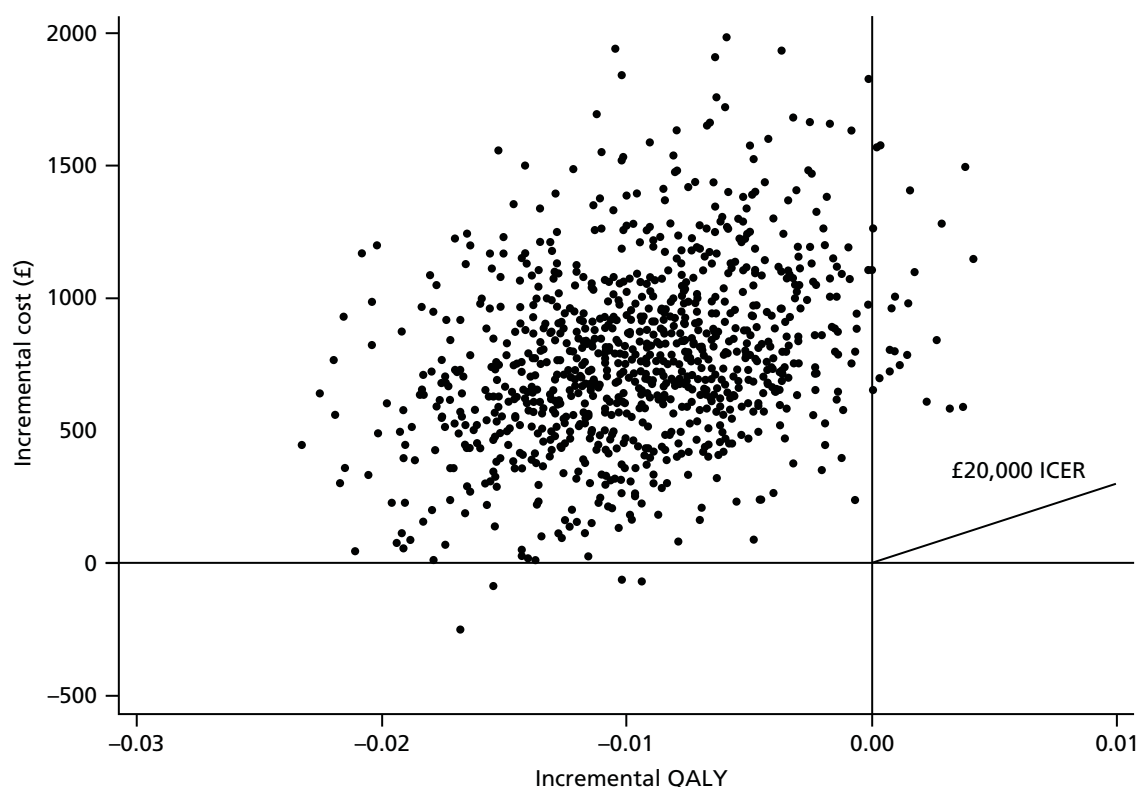

FIGURE 15 Cost-effectiveness plane for the LUCAS-2 device compared with manual chest compression. MI analysis based on 1000 bootstrap replications.

TABLE 24 Incremental cost-effectiveness ratios from lifetime analysis

Analysis	Incremental		ICER
	Cost (£)	QALY	
Base-case analysis (aged 60 years cohort)	2376.40	-0.1286	Manual CPR dominates
One-way sensitivity analyses			
<i>Sensitivity to costs</i>			
+20% of costs	2851.60	-0.1286	Manual CPR dominates
-20% of costs	1901.10	-0.1286	Manual CPR dominates
<i>Sensitivity to QALY</i>			
+20% of QALY	2376.40	-0.1543	Manual CPR dominates
-20% of QALY	2376.40	-0.1029	Manual CPR dominates
<i>Sensitivity to 1-year mortality</i>			
+20% 1-year mortality	-3987.50	-0.0187	£213,014 per QALY
-20% 1-year mortality	10,603.80	-0.2401	Manual CPR dominates

Figure 16 shows the results from the probabilistic sensitivity analysis that takes parameter uncertainty into account. The CEAC indicates that the probability that the LUCAS-2 device is cost-effective is only around 20%, irrespective of the value of λ .

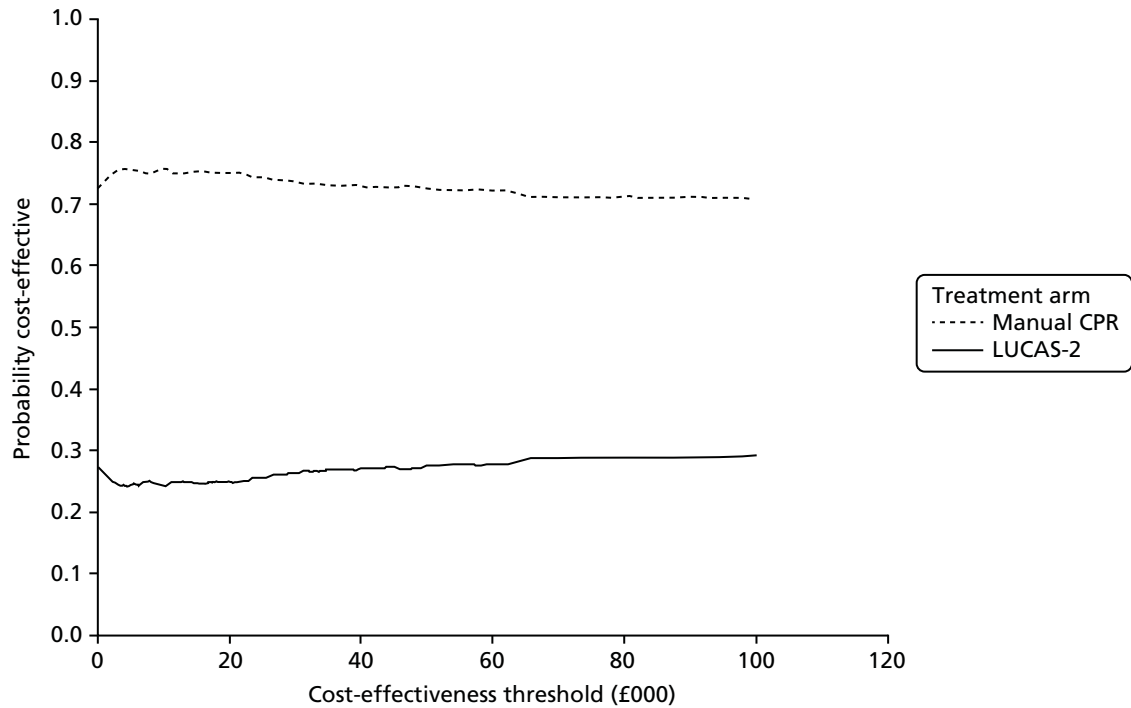

FIGURE 16 Cost-effectiveness acceptability curves for the LUCAS-2 device compared with manual CPR.

Chapter 6 Discussion

Summary of main results

This pragmatic, cluster randomised trial found that the introduction of the LUCAS-2 device into routine ambulance service use did not improve outcomes after OHCA. There was no improvement in survival to 30 days or survival with a CPC score of 1 or 2. We did not identify any treatment-modifying variables, although there was a suggestion that the LUCAS-2 device might be more effective in patients with initial rhythms of PEA or asystole. In a systematic review, including the five existing trials of mechanical chest compression, there was no evidence of an advantage to mechanical chest compression for any outcomes, including survival and survival with good neurological function.

The findings of worse neurological outcomes and lower survival in patients presenting with an initially shockable rhythm was unexpected. Although these analyses were defined a priori, they were not the primary objective of the trial and should be interpreted with caution and deemed as hypothesis generating. One of these hypotheses is that interruptions in CPR during device deployment could cause reduced cardiac and cerebral perfusion. Alternatively, slightly more patients received adrenaline after randomisation in the LUCAS-2 group than in the control group, which might increase cardiac instability and impair cerebral microcirculation. Finally, deployment of the LUCAS-2 device before the first shock is likely to have led to a delay in the time to first shock, which might, in itself, reduce survival.¹⁹

Strengths and limitations

This was a pragmatic study designed to assess the effectiveness of the LUCAS-2 device when implemented in a real-life setting. The intention of the trial was to test the LUCAS-2 device in an environment that was similar to the introduction of a new technology into the NHS.

We chose to use a cluster randomised design with vehicles as the unit of randomisation. The major advantages of this design were that it made implementation of the trial for participating ambulance service staff as simple as possible and it allowed inclusion of eligible cardiac arrests because recruitment was not dependent on a paramedic making a decision to randomise. This meant that one of the major potential drawbacks of cluster randomisation – selection bias – was avoided. Similarly, the design allowed recruitment to proceed quickly, and we successfully recruited nearly 4500 patients in 38 months. Selection bias could still be possible with this design, if there was a lower threshold for initiation of resuscitation if a LUCAS-2 device was present, although this potential bias could occur with any design and is not limited to cluster randomisation. The independent DMC monitored possible selection biases throughout the trial, by looking at the proportions of patients resuscitated when the LUCAS-2 device and control vehicles were first on scene and the characteristics of patients recruited to the two trial groups. There was no evidence of any substantial selection bias.

Our approach to training staff in use of the new technology was pragmatic and reflected the training that would be delivered when rolling out new technology across UK ambulance services. The training package was developed and delivered by experienced ambulance training staff. In the UK, the average ambulance paramedic encounters only one or two cardiac arrests per year and CPR update training is provided annually, so it is unlikely that, if the LUCAS-2 device was introduced into routine service, individuals would have extensive opportunities to practice with it and become expert in its use. The success of implementation is particularly important when considering the potential benefits and harms of mechanical chest compression, as interruptions in CPR and delays in device deployment are a major factor that can impact on outcomes.

Non-compliance in the LUCAS-2 arm was a major feature of this study: only 985 (60%) of 1652 patients randomly assigned to the LUCAS-2 group received mechanical chest compression. We expected that the LUCAS-2 device would not be used in approximately 15% of cases. These were situations in which use of the LUCAS-2 device would be impossible or inappropriate and would occur in clinical practice as often as they occurred in the trial. This includes patients who were too large or too small for the device, cases when the device malfunctioned, situations in which physical space restrictions or constraints made the use of the LUCAS-2 device impossible and cases in which a solo responder was first on scene and did not have the LUCAS-2 device. This usually occurred because the initial emergency call was not for cardiac arrest, so the LUCAS-2 device was not part of the equipment that would be initially taken to the patient. However, a significant proportion of non-uses of the LUCAS-2 device occurred for reasons that were related to the conduct of a research project and would not arise in normal clinical practice. These included the crew not having been trained in the trial procedures the LUCAS-2 device having been removed from the vehicle and errors by the crew about the study protocol.

The sample size was increased to maintain the power of the study to compensate for non-compliance in the LUCAS-2 arm. We also performed CACE analyses to investigate whether or not non-compliance affected the estimates of the treatment effect in the primary ITT analysis. The CACE analyses suggested that, if anything, outcomes were worse if the LUCAS-2 device was actually used and did not suggest that non-compliance had obscured a treatment benefit.

We attempted to measure the quality of CPR provided during the trial resuscitation attempts, in both the manual and LUCAS-2 arms. Unfortunately, this ultimately proved impossible. Our initial plan was to download electrocardiography (ECG) recordings from defibrillators, but this proved impossible because of the different models of defibrillator in use in the four ambulance services, their different data recording capabilities and the logistics of ensuring that the recordings were downloaded and stored at the appropriate time. We also attempted to use the data automatically recorded by the LUCAS-2 devices to verify their use during resuscitations. This was unsuccessful because of the difficulty of extracting data from the devices (it could be done only at the periodic servicing points) and the difficulty of reconciling the times and dates on the LUCAS-2 device recordings with the ambulance service records of the times and dates of resuscitation attempts. The data on performance of ambulance service personnel on the manikins may not be representative of the quality of CPR under field conditions.

The economic analysis was primarily based on data that were collected alongside the trial, which improves internal validity. In addition, linkage with large administrative data sets, including the HES data, was used to obtain resource use estimates that are more accurate than those obtained using retrospective surveys of patients. Of course, the long-term decision model relied on a number of assumptions and existing evidence was scarce for some parameters. We are confident, however, that it captured the most relevant relative costs and outcomes of the LUCAS-2 device compared with manual CPR. It is worth noting that a value of information analysis was not conducted, as the cost-effectiveness results were robust to a wide range of assumptions and the uncertainty around the dominance of manual CPR over the LUCAS-2 device was low (also, the key parameter of the model – the effectiveness of LUCAS-2 – was derived from the best possible source of evidence).

Other evidence

The systematic review of mechanical chest compression included five randomised trials, involving > 10,000 participants. The combined treatment effect did not suggest benefit to mechanical chest compression and no individual study found benefit. The results for survival with good neurological outcome were heterogeneous and both CIs and prediction intervals were wide and did not rule out benefit in some trials.

One important difference between the PARAMEDIC trial⁷³ and other industry-sponsored trials^{70,71} was that they included elements that differed from routine practice. These included more intensive initial and re-training, a run-in period,⁷¹ and, in one study a threshold for quality of implementation, whereby patients were excluded if the threshold was not attained.

Another key difference between this and other recent trials was the absence of CPR feedback technology in the participating ambulance services. CPR feedback devices allow the measurement and adjustment of CPR quality.⁹⁶ Although international guidelines published in 2010 suggested that the devices could be considered as part of an overall strategy to improve CPR quality,³ their adoption into clinical practice has been variable. The scarcity of this technology limited our ability to report on the quality of CPR and monitor the performance of our implementation strategy. These findings serve to highlight the potential limitations of expecting the findings from efficacy trials to translate to real-life practice, for which the same degree of rigour, attention and assessment does not apply.

One earlier mechanical chest compression trial, ASPIRE,⁵⁵ found unfavourable results for survival and neurological outcome, similar to the PARAMEDIC trial.⁷¹ It was suggested that these effects were largely due to heterogeneity of treatment effects between sites and a re-analysis⁹⁷ suggested that the unfavourable outcomes may have been due to protocol changes at one trial site (of five). However, the study investigators disagreed with this interpretation.⁹⁸ The finding of a similar result on survival with good CPC score in the PARAMEDIC trial⁷¹ gives some support to this finding.

Some of the other trials were successful in collecting at least some data on the quality of CPR provided in their manual compression arms. In the CIRC trial,⁷¹ CPR quality data were collected from 96% of participants and showed compression fractions in the first 5 minutes of 79.0% (SD 12.3%) in the manual group and 74.7% (SD 12.7%) in the mechanical arm. The target compression rates in the two arms of this trial were different: 100/minute in the manual arm and 80/minute in the mechanical arm. The target was achieved more often in the manual arm: median compression rate in the manual arm was 89.9 (IQR 79.3–100.3), but in the mechanical arm it was 65.9 (IQR 61.3–70.2). In LUCAS in Cardiac Arrest (LINC),⁷⁰ compression fraction was recorded from 10% of patients and was 84% in the mechanical compression group and 78% in the manual group. The ASPIRE trial⁵⁵ recorded compression fraction in the first 5 minutes from 45% of the manual compression group and 52% of the mechanical compression group; it was very similar, at 0.6 (SD 0.2) in the manual arm and 0.59 (SD 0.21) in the mechanical arm. The remaining two trials did not report any information on CPR quality. Recording of CPR quality in the context of a pragmatic trial is extremely challenging and may influence the trial's interpretation. For example, although the CIRC trial⁷¹ did not demonstrate benefit to mechanical chest compression and the trial's formal conclusion was equivalence (albeit with very wide boundaries for the definition of equivalence), the fact that manual compression was provided well allowed the claim that the mechanical device was as good as manual compression.

Chapter 7 Conclusions

This trial and a meta-analysis of the results from RCTs that enrolled > 10,000 patients do not suggest that mechanical chest compression devices are superior to manual chest compression when used routinely during resuscitation after OHCA. An economic evaluation showed that the LUCAS-2 device was unlikely to be cost-effective. The widespread deployment of devices based on clinical effectiveness does not seem justified. It is possible that mechanical chest compression devices will continue to play a role in resuscitation, as they can deliver chest compressions when manual CPR is difficult or impossible, such as during ambulance transport, and are likely to be the best treatment option in such situations. They may also have an important role in hospitals as a bridge to advanced treatments, such as extracorporeal membrane oxygenation.

Recommendations for research

Mechanical chest compression devices have not been evaluated for CPR during ambulance transport and further research is needed to establish whether or not there is any benefit in such situations.

The use of mechanical devices for in-hospital cardiac arrest has not been adequately evaluated in randomised trials. The results of prehospital studies may not extrapolate to the in-hospital setting because of differences in the patient population and response times, so further trials in this setting may be justified.

Acknowledgements

We would like to thank Gill Price, Regional Head of Clinical Evidence, Research and Development (R&D) Manager, West Midlands Ambulance Service; Sonia Byers, R&D Manager, North East Ambulance Service; Ed England, R&D Manager, South Central Ambulance Service; Ian Teague, Head of Training, South Central Ambulance Service; Susie Hennings, Project Manager, WCTU; Dr Sarah Duggan, Unit Manager, WCTU; Vikki Gordon, Research Nurse & Follow up Co-ordinator, WCTU; Claire Daffern, Quality & Audit Manager, WCTU; Bev Hoddell, Trial Co-ordinator for North East region, WCTU; Sonia Davis, Data Entry Clerk, WCTU; Sarah Rumble, Data Entry Clerk, WCTU; Charlotte Kaye, Trainee Trial Co-ordinator, WCTU; Charlotte Kelly, Health Economist, Academic Unit of Health Economics, Leeds Institute of Health Sciences, University of Leeds; and Thomas Mars, Report Co-ordinator/Editor, WCTU.

Contributions of authors

Simon Gates (Professor of Clinical Trials) was a member of the Trial Management Group, and was involved in the conception and design of the study, the interpretation of data and writing the report.

Ranjit Lall (Principal Research Fellow, Statistics) was a member of the Trial Management Group and was involved in data analysis and writing the report.

Tom Quinn (Professor of Nursing) was a member of the Trial Management Group and was involved in the conception and design of the study and writing the report.

Charles D Deakin (Medical Director) was a member of the Trial Management Group, was lead for the South Central Ambulance Service and was involved in writing the report.

Matthew W Cooke (Professor of Emergency Medicine) was a member of the Trial Management Group and was involved in the conception and design of the study and reviewing report.

Jessica Horton (Trial Co-ordinator) was a member of the Trial Management Group and was involved in study co-ordination and reviewing the report.

Sarah E Lamb (Director of Clinical Trials Unit) was a member of the Trial Management Group and was involved in the conception and design of the study and reviewing report.

Anne-Marie Slowther (Associate Professor, Clinical Ethics) provided specialist advice in ethics and was involved in the design of the study and reviewing report.

Malcolm Woollard (Professor of Pre-hospital Care) was a member of the Trial Management Group and was involved in the conception and design of the study.

Andy Carson (Medical Director) was involved in trial management and was lead for the West Midlands Ambulance Service.

Mike Smyth (Research Fellow, Paramedic) was involved in trial co-ordination, data collection and reviewing the report.

Kate Wilson (Research Fellow, Paramedic) was involved in trial co-ordination, data collection and reviewing the report.

Garry Parcell (Research Fellow, Paramedic) was involved in trial co-ordination, data collection and reviewing the report.

Andrew Rosser (Research Fellow, Paramedic) was involved in trial co-ordination, data collection and reviewing the report.

Richard Whitfield (Director of Research and Development) was involved in design of the study and reviewing the report and was the lead for the Welsh Ambulance Service.

Amanda Williams (Research Fellow, Paramedic) was involved in trial co-ordination, data collection and reviewing the report.

Rebecca Jones (Research Fellow, Paramedic) was involved in trial co-ordination, data collection and reviewing the report.

Helen Pocock (Research Fellow, Paramedic) was involved in trial co-ordination, data collection and reviewing the report.

Nicola Brock (Research Fellow, Paramedic) was involved in trial co-ordination, data collection and reviewing the report.

John JM Black (Medical Director) was involved in trial management and leading the trial in the South Central Ambulance Service.

John Wright (Consultant, Emergency Medicine) was involved in trial management in the North East Ambulance Service.

Kyee Han (Medical Director) was involved in trial management and was lead for the North East Ambulance Service.

Gary Shaw (Research Fellow, Paramedic) was involved in trial co-ordination, data collection and reviewing the report.

Laura Blair (Research Fellow, Paramedic) was involved in trial co-ordination, data collection and reviewing the report.

Joachim Marti (Lecturer, Health Economics) was involved in the health economic evaluation and writing and reviewing the report.

Claire Hulme (Professor of Health Economics) was involved in the design of the study, supervision of the health economics and writing and reviewing report.

Chris McCabe (Professor of Health Economics) was involved in the conception and design of the study and reviewing the report.

Silviya Nikolova (Lecturer, Health Economics) was involved in the health economic evaluation and writing and reviewing the report.

Zenia Ferreira (Research Assistant, Health Economics) was involved in the health economic evaluation and reviewing the report.

Gavin D Perkins (Professor of Critical Care) was a member of the Trial Management Group and was involved in the conception and design of the study and writing and reviewing the report.

Publications

Perkins GD, Lall R, Quinn T, Deakin CD, Cooke MW, Horton J, *et al.* Mechanical versus manual chest compression for out-of-hospital cardiac arrest (PARAMEDIC): a pragmatic, cluster randomised controlled trial. *Lancet* 2015;**385**:947–55.

Perkins GD, Quinn T, Deakin CD, Lall R, Gates S. Mechanical chest compression in the PARAMEDIC trial – authors' reply. *Lancet* 2015;**386**:26–7.

Gates S, Quinn T, Deakin CD, Blair L, Couper K, Perkins GD. Mechanical chest compression for out-of-hospital cardiac arrest: systematic review and meta-analysis. *Resuscitation* 2015;**94**:91–7.

Rajagopal S, Kaye CR, Lall R, Deakin CD, Gates S, Pocock H, *et al.* Characteristics of patients who are not resuscitated in out of hospital cardiac arrests and opportunities to improve community response to cardiac arrest. *Resuscitation* 2016;**109**:110–15.

Pocock H, Deakin CD, Quinn T, Perkins GD, Horton J, Gates S. Human factors in prehospital research: lessons from the PARAMEDIC trial. *Emerg Med J* 2016;**33**:562–8.

Marti J, Hulme C, Ferreira Z, Nikolova S, Lall R, Kaye C, *et al.* The cost-effectiveness of a mechanical compression device in out hospital cardiac arrest. *Resuscitation* 2017; in press.

Data sharing statement

All of the trial data are held in electronic anonymised form by the WCTU. Requests for access to data should be directed to the WCTU manager.

References

1. Jacobs I, Nadkarni V, Bahr J, Berg RA, Billi JE, Bossaert L, *et al.* Cardiac arrest and cardiopulmonary resuscitation outcome reports: update and simplification of the Utstein templates for resuscitation registries. A statement for healthcare professionals from a task force of the International Liaison Committee on resuscitation (American Heart Association, European Resuscitation Council, Australian Resuscitation Council, New Zealand Resuscitation Council, Heart and Stroke Foundation of Canada, InterAmerican Heart Foundation, Resuscitation Council of Southern Africa). *Resuscitation* 2004;**63**:233–49. <https://doi.org/10.1016/j.resuscitation.2004.09.008>
2. Nichol G, Thomas E, Callaway CW, Hedges J, Powell JL, Aufderheide TP, *et al.* Regional variation in out-of-hospital cardiac arrest incidence and outcome. *JAMA* 2008;**300**:1423–31. <https://doi.org/10.1001/jama.300.12.1423>
3. Deakin CD, Nolan JP, Soar J, Sunde K, Koster RW, Smith GB, Perkins GD. European Resuscitation Council Guidelines for Resuscitation 2010 Section 4. Adult advanced life support. *Resuscitation* 2010;**81**:1305–52. <https://doi.org/10.1016/j.resuscitation.2010.08.017>
4. Nolan J, Soar J, Eikeland H. The chain of survival. *Resuscitation* 2006;**71**:270–1. <https://doi.org/10.1016/j.resuscitation.2006.09.001>
5. Sasson C, Rogers MA, Dahl J, Kellermann AL. Predictors of survival from out-of-hospital cardiac arrest: a systematic review and meta-analysis. *Circ Cardiovasc Qual Outcomes* 2010;**3**:63–81. <https://doi.org/10.1161/CIRCOUTCOMES.109.889576>
6. Koster RW, Baubin MA, Bossaert LL, Caballero A, Cassan P, Castren M, *et al.* European Resuscitation Council Guidelines for Resuscitation 2010. Section 2. Adult basic life support and use of automated external defibrillators. *Resuscitation* 2010;**81**:1277–92. <https://doi.org/10.1016/j.resuscitation.2010.08.009>
7. Wik L, Steen PA, Bircher NG. Quality of bystander cardiopulmonary resuscitation influences outcome after prehospital cardiac arrest. *Resuscitation* 1994;**28**:195–203. [https://doi.org/10.1016/0300-9572\(94\)90064-7](https://doi.org/10.1016/0300-9572(94)90064-7)
8. Babbs CF, Voorhees WD, Fitzgerald KR, Holmes HR, Geddes LA. Relationship of blood pressure and flow during CPR to chest compression amplitude: evidence for an effective compression threshold. *Ann Emerg Med* 1983;**12**:527–32. [https://doi.org/10.1016/S0196-0644\(83\)80290-X](https://doi.org/10.1016/S0196-0644(83)80290-X)
9. Ornato JP, Levine RL, Young DS, Racht EM, Garnett AR, Gonzalez ER. The effect of applied chest compression force on systemic arterial pressure and end-tidal carbon dioxide concentration during CPR in human beings. *Ann Emerg Med* 1989;**18**:732–7. [https://doi.org/10.1016/S0196-0644\(89\)80005-8](https://doi.org/10.1016/S0196-0644(89)80005-8)
10. Edelson DP, Abella BS, Kramer-Johansen J, Wik L, Myklebust H, Barry AM, *et al.* Effects of compression depth and pre-shock pauses predict defibrillation failure during cardiac arrest. *Resuscitation* 2006;**71**:137–45. <https://doi.org/10.1016/j.resuscitation.2006.04.008>
11. Stiell IG, Brown SP, Christenson J, Cheskes S, Nichol G, Powell J, *et al.* What is the role of chest compression depth during out-of-hospital cardiac arrest resuscitation? *Crit Care Med* 2012;**40**:1192–8. <https://doi.org/10.1097/CCM.0b013e31823bc8bb>
12. Stiell IG, Brown SP, Nichol G, Cheskes S, Vaillancourt C, Callaway CW, *et al.* What is the optimal chest compression depth during out-of-hospital cardiac arrest resuscitation of adult patients? *Circulation* 2014;**130**:1962–70. <https://doi.org/10.1161/CIRCULATIONAHA.114.008671>

13. Abella BS, Sandbo N, Vassilatos P, Alvarado JP, O'Hearn N, Wigder HN, *et al.* Chest compression rates during cardiopulmonary resuscitation are suboptimal: a prospective study during in-hospital cardiac arrest. *Circulation* 2005;**111**:428–34. <https://doi.org/10.1161/01.CIR.0000153811.84257.59>
14. Idris AH, Guffey D, Aufderheide TP, Brown S, Morrison LJ, Nichols P, *et al.* Relationship between chest compression rates and outcomes from cardiac arrest. *Circulation* 2012;**125**:3004–12. <https://doi.org/10.1161/CIRCULATIONAHA.111.059535>
15. Idris AH, Guffey D, Pepe PE, Brown SP, Brookes SC, Callaway CW, *et al.* Chest compression rates and survival following out-of-hospital cardiac arrest. *Crit Care Med* 2015;**43**:840–8. <https://doi.org/10.1097/CCM.0000000000000824>
16. Zuercher M, Hilwig RW, Ranger-Moore J, Nysaether J, Nadkarni VM, Berg MD, *et al.* Leaning during chest compressions impairs cardiac output and left ventricular myocardial blood flow in piglet cardiac arrest. *Crit Care Med* 2010;**38**:1141–6. <https://doi.org/10.1097/CCM.0b013e3181ce1fe2>
17. Vaillancourt C, Everson-Stewart S, Christenson J, Andrusiek D, Powell J, Nichol G, *et al.* The impact of increased chest compression fraction on return of spontaneous circulation for out-of-hospital cardiac arrest patients not in ventricular fibrillation. *Resuscitation* 2011;**82**:1501–7. <https://doi.org/10.1016/j.resuscitation.2011.07.011>
18. Cheskes S, Schmicker RH, Christenson J, Salcido DD, Rea T, Powell J, *et al.* Perishock pause: an independent predictor of survival from out-of-hospital shockable cardiac arrest. *Circulation* 2011;**124**:58–66. <https://doi.org/10.1161/CIRCULATIONAHA.110.010736>
19. Valenzuela TD, Roe DJ, Cretin S, Spaite DW, Larsen MP. Estimating effectiveness of cardiac arrest interventions: a logistic regression survival model. *Circulation* 1997;**96**:3308–13. <https://doi.org/10.1161/01.CIR.96.10.3308>
20. Deakin CD, Morrison LJ, Morley PT, Callaway CW, Kerber RE, Kronick SL, *et al.* Part 8: Advanced life support: 2010 International Consensus on Cardiopulmonary Resuscitation and Emergency Cardiovascular Care Science with Treatment Recommendations. *Resuscitation* 2010;**81**:e93–174. <https://doi.org/10.1016/j.resuscitation.2010.08.027>
21. Stiell IG, Nichol G, Leroux BG, Rea TD, Ornato JP, Powell J, *et al.* Early versus later rhythm analysis in patients with out-of-hospital cardiac arrest. *N Engl J Med* 2011;**365**:787–97. <https://doi.org/10.1056/NEJMoa1010076>
22. Rea T, Prince D, Morrison L, Callaway C, Aufderheide T, Daya M, *et al.* Association between survival and early versus later rhythm analysis in out-of-hospital cardiac arrest: do agency-level factors influence outcomes? *Ann Emerg Med* 2014;**64**:1–8. <https://doi.org/10.1016/j.annemergmed.2014.01.014>
23. Nolan JP, Neumar RW, Adrie C, Aibiki M, Berg RA, Bottiger BW, *et al.* Post-cardiac arrest syndrome: epidemiology, pathophysiology, treatment, and prognostication. A Scientific Statement from the International Liaison Committee on Resuscitation; the American Heart Association Emergency Cardiovascular Care Committee; the Council on Cardiovascular Surgery and Anesthesia; the Council on Cardiopulmonary, Perioperative, and Critical Care; the Council on Clinical Cardiology; the Council on Stroke. *Resuscitation* 2008;**79**:350–79. <https://doi.org/10.1016/j.resuscitation.2008.09.017>
24. Perkins GD, Cooke MW. Variability in cardiac arrest survival: the NHS Ambulance Service Quality Indicators. *Emerg Med J* 2012;**29**:3–5. <https://doi.org/10.1136/emered-2011-200758>
25. Soar J, Monsieurs KG, Ballance JH, Barelli A, Biarent D, Greif R, *et al.* European Resuscitation Council Guidelines for Resuscitation 2010. Section 9. Principles of Education in Resuscitation. *Resuscitation* 2010;**81**:1434–44. <https://doi.org/10.1016/j.resuscitation.2010.08.014>

26. Elliott VJ, Rodgers DL, Brett SJ. Systematic review of quality of life and other patient-centred outcomes after cardiac arrest survival. *Resuscitation* 2011;**82**:247–56. <https://doi.org/10.1016/j.resuscitation.2010.10.030>
27. Ornato JP, Becker LB, Weisfeldt ML, Wright BA. Cardiac arrest and resuscitation: an opportunity to align research prioritization and public health need. *Circulation* 2010;**122**:1876–9. <https://doi.org/10.1161/CIRCULATIONAHA.110.963991>
28. Gates S, Smith JL, Ong GJ, Brace SJ, Perkins GD. Effectiveness of the LUCAS device for mechanical chest compression after cardiac arrest: systematic review of experimental, observational and animal studies. *Heart* 2012;**98**:908–13. <https://doi.org/10.1136/heartjnl-2011-301571>
29. Axelsson C, Nestin J, Svensson L, Axelsson AB, Herlitz J. Clinical consequences of the introduction of mechanical chest compression in the EMS system for treatment of out-of-hospital cardiac arrest—a pilot study. *Resuscitation* 2006;**71**:47–55. <https://doi.org/10.1016/j.resuscitation.2006.02.011>
30. De Wilde R, van der Weijden P, de Haan M, Bosch J, de Nooij J, Harinck HIJ. ROSC at hospital admission in out of hospital cardiac arrest using LUCAS. *Resuscitation* 2008;**77**(Suppl.):49.
31. Maule Y. Mechanical external chest compression: a new adjuvant technology in cardiopulmonary resuscitation. *Urgences & Accueil* 2007;**7**:4–7.
32. Smekal D, Johansson J, Huzevka T, Rubertsson S. A pilot study of mechanical chest compressions with the LUCAS™ device in cardiopulmonary resuscitation. *Resuscitation* 2011;**82**:702–6. <https://doi.org/10.1016/j.resuscitation.2011.01.032>
33. Liao Q, Sjöberg T, Paskevicius A, Wolfnart B, Steen S. Manual versus mechanical cardiopulmonary resuscitation. An experimental study in pigs. *BMC Cardiovasc Disord* 2010;**10**:53.
34. Rubertsson S, Karlsten R. Increased cortical cerebral flow with LUCAS; a new device for mechanical chest compressions compared to standard external compressions during experimental cardiopulmonary resuscitation. *Resuscitation* 2005;**65**:357–63.
35. Steen S, Liao Q, Pierre L, Paskevicius A, Sjöberg T. Evaluation of LUCAS, a new device for automatic mechanical compression and active decompression resuscitation. *Resuscitation* 2002;**55**:285–99. [https://doi.org/10.1016/S0300-9572\(02\)00271-X](https://doi.org/10.1016/S0300-9572(02)00271-X)
36. Olasveengen TM, Wik S, Steen PA. Quality of cardiopulmonary resuscitation before and during transport in out-of-hospital cardiac arrest. *Resuscitation* 2007;**76**:185–90.
37. Truhlar A, Hejna P, Zabka L, Zatopkova L, Cerny V. Injuries caused by the autopulse and LUCAS II resuscitation systems compared to manual chest compressions. *Resuscitation* 2010;**81**(Suppl. 2):62.
38. Steen S, Sjöberg T, Olsson P, Young M. Treatment of out-of-hospital cardiac arrest with LUCAS, a new device for automatic mechanical compression and active decompression resuscitation. *Resuscitation* 2005;**67**:25–30. <https://doi.org/10.1016/j.resuscitation.2005.05.013>
39. Woollard M, Mackway-Jones K. All that glistens is not gold. *Emerg Med J* 2008;**25**:251–2. <https://doi.org/10.1136/emj.2008.057711>
40. Joint Royal College Ambulance Liaison Committee (JRCALC). *Mechanical Compression: Request for Advice on Continued but Limited and Centrally Supervised Deployment by Ambulance Trusts That are Currently Using LUCAS or AutoPulse Devices*. URL: www.jrcalc.org.uk/wp-content/uploads/2013/11/LUCASForMedDirectors.pdf (accessed 20 January 2016).

41. Gazmuri RJ, Nolan JP, Nadkarni VM, Arntz HR, Billi JE, Bossaert L, *et al.* Scientific knowledge gaps and clinical research priorities for cardiopulmonary resuscitation and emergency cardiovascular care identified during the 2005 International Consensus Conference on ECC and CPR Science with Treatment Recommendations. A consensus statement from the International Liaison Committee on Resuscitation; the American Heart Association Emergency Cardiovascular Care Committee; the Stroke Council; and the Cardiovascular Nursing Council. *Resuscitation* 2007;**75**:400–11. <https://doi.org/10.1016/j.resuscitation.2007.09.008>
42. Perkins GD, Woollard M, Cooke MW, Deakin C, Horton J, Lall R, *et al.* Prehospital randomised assessment of a mechanical compression device in cardiac arrest (PaRAMeDIC) trial protocol. *Scand J Trauma Resusc Emerg Med* 2010;**18**:58. <https://doi.org/10.1186/1757-7241-18-58>
43. Health Assessment Laboratory. *Short Form 12 Health Survey, 1992–2002*. Hanover, NH: Medical Outcomes Trust and Quality Metric Inc.; 2002.
44. EuroQol Group. EuroQol: a new facility for the measurement of health-related quality of life. *Health Policy* 1990;**16**:199–208. [https://doi.org/10.1016/0168-8510\(90\)90421-9](https://doi.org/10.1016/0168-8510(90)90421-9)
45. Safar P. Resuscitation after Brain Ischemia. In Grenvik A, Safar P, editors. *Brain Failure and Resuscitation*. New York, NY: Churchill Livingstone; 1981. pp. 155–84.
46. Folstein MF, Folstein SE, McHugh PR. "Mini-mental State". A practical method for grading the cognitive state of patients for the clinician. *J Psychiatr Res* 1975;**12**:189–98. [https://doi.org/10.1016/0022-3956\(75\)90026-6](https://doi.org/10.1016/0022-3956(75)90026-6)
47. Zigmond AS, Snaith RP. The hospital anxiety and depression scale. *Acta Psychiatr Scand* 1983;**67**:361–70. <https://doi.org/10.1111/j.1600-0447.1983.tb09716.x>
48. Weathers F, Litz BT, Huska JA, Keane TM. *PTSD Checklist Civilian Version*. Boston, MA: National Center for PTSD Behavioral Science Division; 1994.
49. Langhelle A, Nolan J, Herlitz J, Castren M, Wenzel V, Soreide E, *et al.* Recommended guidelines for reviewing, reporting, and conducting research on post-resuscitation care: the Utstein style. *Resuscitation* 2005;**66**:271–83. <https://doi.org/10.1016/j.resuscitation.2005.06.005>
50. Arawwawala D, Brett SJ. Clinical review: beyond immediate survival from resuscitation-long-term outcome considerations after cardiac arrest. *Crit Care* 2007;**11**:235. <https://doi.org/10.1186/cc6139>
51. O'Reilly SM, Grubb N, O'Carroll RE. Long-term emotional consequences of in-hospital cardiac arrest and myocardial infarction. *Br J Clin Psychol* 2004;**43**:83–95. <https://doi.org/10.1348/014466504772812986>
52. Sunnerhagen KS, Johansson O, Herlitz J, Grimby G. Life after cardiac arrest; a retrospective study. *Resuscitation* 1996;**31**:135–40. [https://doi.org/10.1016/0300-9572\(95\)00903-5](https://doi.org/10.1016/0300-9572(95)00903-5)
53. Fisher JD, Brown SN, Cooke MW, editors. *UK Ambulance Service Clinical Practice Guidelines 2006*. London: Joint Royal Colleges Ambulance Liaison Committee; 2006.
54. Department of Health. *Mental Capacity Act*. London: HMSO; 2005.
55. Nolan JP, Laver SR, Welch CA, Harrison DA, Gupta V, Rowan K. Outcome following admission to UK intensive care units after cardiac arrest: a secondary analysis of the ICNARC Case Mix Programme Database. *Anaesthesia* 2007;**62**:1207–16. <https://doi.org/10.1111/j.1365-2044.2007.05232.x>
56. Griffiths JA, Morgan K, Barber VS, Young JD. Study protocol: the Intensive Care Outcome Network ('ICON') study. *BMC Health Serv Res* 2008;**8**:132. <https://doi.org/10.1186/1472-6963-8-132>
57. PARAMEDIC – University of Warwick. *PARAMEDIC Trial Procedures*: URL: www.warwick.ac.uk/go/paramedic (accessed 20 January 2016).

58. Resuscitation Council (UK). *Guidelines 2010*. URL: <https://www.resus.org.uk/archive/guidelines-2010/> (accessed 20 January 2016).
59. National Research Ethics Service (NRES). *Progress and Safety Reporting – Health Research Authority*. URL: www.hra.nhs.uk/resources/during-and-after-your-study/progress-and-safety-reporting/ (accessed 20 January 2016).
60. Great Britain. *Data Protection Act*. London: Stationery Office; 1998.
61. Warwick Clinical Trials Unit (WCTU). *Standard Operating Procedures*. URL: www2.warwick.ac.uk/fac/med/research/hscience/ctu/conducting/ (accessed 20 January 2016)
62. Lafuente-Lafuente C, Melero-Bascones M. Active chest compression-decompression for cardiopulmonary resuscitation. *Cochrane Database Syst Rev* 2013;**2**:CD002751. <https://doi.org/10.1002/14651858.cd002751.pub3>
63. Donohoe R, Mawson S. *London Ambulance Service. Cardiac Arrest Annual Report 2006/2007*. London: London Ambulance Service NHS Trust; 2007.
64. Ambulance Service Association/Joint Royal Colleges Ambulance Liaison Committee (ASA/JRCALC). *National Out of Hospital cardiac Arrest Project*. 2006.
65. Pell JP, Sirel J, Marsden AK, Cobbe SM. Seasonal variations in out of hospital cardiopulmonary arrest. *Heart* 1999;**82**:680–3. <https://doi.org/10.1136/hrt.82.6.680>
66. Dunn G, Maracy M, Dowrick C, Ayuso-Mateos JL, Dalgard OS, Page H, *et al*. Estimating psychological treatment effects from a randomised controlled trial with both non-compliance and loss to follow-up. *Br J Psychiatry* 2003;**183**:323–31. <https://doi.org/10.1192/bjp.183.4.323>
67. Hewitt CE, Torgerson DJ, Miles JN. Is there another way to take account of noncompliance in randomized controlled trials? *CMAJ* 2006;**175**:347. <https://doi.org/10.1503/cmaj.051625>
68. Royston P, Sauerbrei W. A new approach to modelling interactions between treatment and continuous covariates in clinical trials by using fractional polynomials. *Stat Med* 2004;**23**:2509–25. <https://doi.org/10.1002/sim.1815>
69. Research Governance Framework for Health and Social Care. *Research Governance Framework for Health and Social Care: Second Edition*. London: Department of Health; 2005. URL: www.dh.gov.uk/en/Publicationsandstatistics/Publications/PublicationsPolicyAndGuidance/DH_4108962 (accessed 20 January 2016).
70. Rubertsson S, Lindgren E, Smekal D, Ostlund O, Silfverstolpe J, Lichtveld RA, *et al*. Mechanical chest compressions and simultaneous defibrillation vs conventional cardiopulmonary resuscitation in out-of-hospital cardiac arrest: the LINC randomised trial. *JAMA* 2014;**311**:53–61. <https://doi.org/10.1001/jama.2013.282538>
71. Wik L, Olsen JA, Persse D, Sterz F, Lozano MJr, Brouwer MA, *et al*. Manual vs. integrated automatic load-distributing band CPR with equal survival after out of hospital cardiac arrest. The randomised CIRC trial. *Resuscitation* 2014;**85**:741–8. <https://doi.org/10.1016/j.resuscitation.2014.03.005>
72. Hallstrom A, Rea TD, Sayre MR, Christenson J, Anton AR, Mosesso VN, *et al*. Manual chest compression vs use of an automated chest compression device during resuscitation following out-of-hospital cardiac arrest: a randomized trial. *JAMA* 2006;**295**:2620–8. <https://doi.org/10.1001/jama.295.22.2620>
73. Perkins GD, Lall R, Quinn T, Deakin CD, Cooke MW, Horton J, *et al*. Mechanical versus manual chest compression for out-of-hospital cardiac arrest (PARAMEDIC): a pragmatic, cluster randomised controlled trial. *Lancet* 2015;**385**:947–55. [https://doi.org/10.1016/S0140-6736\(14\)61886-9](https://doi.org/10.1016/S0140-6736(14)61886-9)

74. Brooks SC, Hassan N, Bigham BL, Morrison LJ. Mechanical versus manual chest compressions for cardiac arrest. *Cochrane Database Syst Rev* 2014;**2**:CD007260. <https://doi.org/10.1002/14651858.cd007260.pub3>
75. Perkins GD, Jacobs IG, Nadkarni VM, Berg RA, Bhanji F, Biarent D, *et al.* Cardiac arrest and cardiopulmonary resuscitation outcome reports: update of the Utstein Resuscitation Registry Templates for Out-of-Hospital Cardiac Arrest: a statement for healthcare professionals from a task force of the International Liaison Committee on Resuscitation (American Heart Association, European Resuscitation Council, Australian and New Zealand Council on Resuscitation, Heart and Stroke Foundation of Canada, InterAmerican Heart Foundation, Resuscitation Council of Southern Africa, Resuscitation Council of Asia); and the American Heart Association Emergency Cardiovascular Care Committee and the Council on Cardiopulmonary, Critical Care, Perioperative and Resuscitation. *Resuscitation* 2015;**132**:1286–300. <https://doi.org/10.1161/cir.000000000000144>
76. Riley RD, Higgins JP, Deeks JJ. Interpretation of random effects meta-analyses. *BMJ* 2011;**342**:d549. <https://doi.org/10.1136/bmj.d549>
77. Lerner EB, Persse D, Souders CM, Sterz F, Malzer R, Lozano M, *et al.* Design of the Circulation Improving Resuscitation Care (CIRC) trial: a new state of the art design for out-of-hospital cardiac arrest research. *Resuscitation* 2011;**82**:294–9. <https://doi.org/10.1016/j.resuscitation.2010.11.013>
78. Whitehead J, Brunier H. The double triangular test: a sequential test for the two-sided alternative with early stopping under the null hypothesis. *Sequential Analysis* 1990;**9**:117–36. <https://doi.org/10.1080/07474949008836200>
79. National Institute for Health and Care Excellence (NICE). *Guide to the Methods of Technology Appraisal*. 2013. URL: <https://publications.nice.org.uk/pmg9> (accessed 20 January 2016).
80. Kaarlola A, Pettilä V, Kekki P. Performance of two measures of general health-related quality of life, the EQ-5D and the RAND-36 among critically ill patients. *Intensive Care Med* 2004;**30**:2245–52. <https://doi.org/10.1007/s00134-004-2471-6>
81. Dolan P. Modeling valuations for EuroQol health states. *Med Care* 1997;**35**:1095–108. <https://doi.org/10.1097/00005650-199711000-00002>
82. Thalanany MM, Mugford M, Hibbert C, Cooper NJ, Truesdale A, Robinson S, *et al.* Methods of data collection and analysis for the economic evaluation alongside a national, multi-centre trial in the UK: conventional ventilation or ECMO for Severe Adult Respiratory Failure (CESAR). *BMC Health Serv Res* 2008;**8**:94. <https://doi.org/10.1186/1472-6963-8-94>
83. Vainiola T, Roine RP, Pettilä V, Kantola T, Räsänen P, Sintonen H. Effect of health-related quality-of-life instrument and quality-adjusted life year calculation method on the number of life years gained in the critical care setting. *Value Health* 2011;**14**:1130–4. <https://doi.org/10.1016/j.jval.2011.05.047>
84. Ferguson ND, Scales DC, Pinto R, Wilcox ME, Cook DJ, Guyatt GH, *et al.* Integrating mortality and morbidity outcomes: using quality-adjusted life years in critical care trials. *Am J Respir Crit Care Med* 2013;**187**:256–61. <https://doi.org/10.1164/rccm.201206-1057OC>
85. Department of Health (DH). *NHS Reference Costs 2013–14*. URL: <https://www.gov.uk/government/publications/nhs-reference-costs-2013-to-2014> (accessed 20 January 2016).
86. Curtis L. *Unit Costs of Health and Social Care 2012*. Personal Social Services Research Unit (PSSRU), 2012. URL: www.pssru.ac.uk/project-pages/unit-costs/2012/ (accessed 20 January 2016).
87. Rubin DB. Multiple imputation after 18+ years. *J Am Stat Assoc* 1996;**91**:473–89. <https://doi.org/10.1080/01621459.1996.10476908>
88. Drummond MF, Sculpher MJ, Torrance GW, O'Brian BJ, Stoddart GL. *Methods for the Economic Evaluation of Health Care Programmes*. 3rd edn. New York, NY: Oxford University Press; 2005.

89. Van Hout BA, Al MJ, Gordon GS, Rutten FF. Costs, effects and C/E-ratios alongside a clinical trial. *Health Econ* 1994;**3**:309–19. <https://doi.org/10.1002/hec.4730030505>
90. Fenwick E, O'Brien BJ, Briggs A. Cost-effectiveness acceptability curves: facts, fallacies and frequently asked questions. *Health Econ* 2004;**13**:405–15. <https://doi.org/10.1002/hec.903>
91. Sonnenberg FA, Beck JR. Markov models in medical decision making: a practical guide. *Med Decis Making* 1993;**13**:322–38. <https://doi.org/10.1177/0272989X9301300409>
92. Office for National Statistics (ONS). *Historic and Projected Mortality Data (1951–2060) from the UK Life Tables, 2010-Based*. London, March 2012. URL: www.ons.gov.uk/ons/publications/re-reference-tables.html?edition=tcM%3A77-257453. (accessed 20 January 2016).
93. Phelps R, Dumas F, Maynard C, Silver J, Rea T. Cerebral Performance Category and long-term prognosis following out-of-hospital cardiac arrest. *Crit Care Med* 2013;**41**:1252–7. <https://doi.org/10.1097/CCM.0b013e31827ca975>
94. Stinnet A, Mullahy J. Net health benefits: a new framework for the analysis of uncertainty in cost-effectiveness analysis. *Med Decis Making* 1998;**18**:S68–80. <https://doi.org/10.1177/0272989X98018002509>
95. Ramsey S, Willke R, Briggs A, Brown R, Buxton M, Chawla A, *et al.* Good research practices for cost-effectiveness analysis alongside clinical trials: the ISPOR RCT-CEA Task Force report. *Value Health* 2005;**8**:521–33. <https://doi.org/10.1111/j.1524-4733.2005.00045.x>
96. Yeung J, Meeks R, Edelson D, Gao F, Soar J, Perkins GD. The use of CPR feedback/prompt devices during training and CPR performance: a systematic review. *Resuscitation* 2009;**80**:743–51. <https://doi.org/10.1016/j.resuscitation.2009.04.012>
97. Paradis NA, Young G, Lemeshow S, Brewer JE, Halperin HR. Inhomogeneity and temporal effects in AutoPulse Assisted Prehospital International Resuscitation: an exception from consent trial terminated early. *Am J Emerg Med* 2010;**28**:391–8. <https://doi.org/10.1016/j.ajem.2010.02.002>
98. Hallstrom A, Rea TD, Sayre MR, Christenson J, Cobb L, Mosesso VN, Anton AR. The AutoPulse Assisted Prehospital International Resuscitation (ASPIRE) trial investigators respond to inhomogeneity and temporal effects assertions. *Am J Emerg Med* 2010;**28**:973–6. <https://doi.org/10.1016/j.ajem.2010.07.001>

Appendix 1 In-hospital data fields

Length of stay		
Sedation status first 24 hours		
Lowest temperature first 24 hours (surrogate for therapeutic hypothermia)		
Number of days of basic cardiovascular, respiratory, organ support		
Number of days advanced cardiovascular, respiratory, renal, GI, neurological, dermatological, liver organ support provided		
Treatment withdrawn status		
Referral for organ donation		
Actual organ donation		
		<i>ICNARC CASE Mix – code</i>
Date of admission		DAH
Residence prior to admission to acute hospital		RESA
Age		DOB
Admission type		PA_V3
Levels of care	Level 3 days	CCLOD
	Level 2 days	CCL2D
	Level 1 days	CCL ID
	Level 0 days	CCLOD
Date of ultimate discharge from ICU/HDU		DUDICU
Date of discharge from your hospital		DDH
Status at discharge from your hospital		HDIS
Destination post discharge from your hospital		DESTH V3
Residence post discharge from hospital		RESD
Classification of surgery	To identify any procedures	CLASSNS
Date of death		DOD
Date of ultimate discharge from hospital	(If transferred to another hospital)	DUDH
Status at ultimate discharge from hospital	(If transferred to another hospital)	UHDIS
Date of first critical care visit post discharge from your unit		DFCCD
Critical care visit post discharge from your unit		CCD

GI, gastrointestinal; HDU, high-dependency unit.

Hospital Episode Statistics: PARAMEDIC – Data Extract Request [V1.0: October 2012 (CK) – updated March 2013 (CK)]

Data required for study participants for 12 months following randomisation.

Hospital Episode Statistics: inpatient

Data fields	Description
Admissions	
Date of admission (admidate)	This field contains the date on which the patient was admitted to hospital at the start of a hospital spell; <i>admidate</i> is recorded on all episodes within a spell
Method of admission (admimeth)	This field contains a code that identifies how the patient was admitted to hospital; <i>admimeth</i> is recorded on the first and also all subsequent episodes within the spell (i.e. where the spell is made up of more than one episode)
Source of admission (admisorc)	This field contains a code that identifies where the patient was immediately prior to admission. Most patients are admitted from home, but there are some significant exceptions. In particular, this field differentiates between patients admitted from home and patients transferred from another hospital provider or institution
Augmented/critical care period	
ACP end date (acpend)	This field gives the end date of a period of augmented care
ACP start date (acpstar)	This field states the start date of a period of augmented care
High-dependency care level (depdays)	This field contains the number of days of high-dependency care in a period of augmented care
Intensive care level days (intdays)	This field contains the number of days of intensive care in a period of augmented care
Number of ACPs within episode (numacp)	This derived field gives the number of ACPs within episode
Clinical	
All diagnosis codes (diag_nn)	There are 20 fields (14 before April 2007 and seven before April 2002), <i>diag_01</i> to <i>diag_20</i> , which contain information about a patient's illness or condition. The field <i>diag_01</i> contains the primary diagnosis. The other fields contain secondary/subsidiary diagnoses. The codes are defined in the ICD-10
All operative procedure codes (oper_nn)	There are 24 fields (12 before April 2007 and four prior to April 2002), <i>oper_01</i> to <i>oper_4</i> , which contain information about a patient's operations. The field <i>oper_01</i> contains the main (i.e. most resource intensive) procedure. The other fields contain secondary procedures. The codes are defined in the tabular list of the <i>Classification of Surgical Operations and Procedures</i> ; the current version is OPCS-4. Procedure codes start with a letter and are followed by two or three digits. The third digit identifies variations on a main procedure code containing two digits. The third digit is preceded by a full stop in OPCS4, but this is not stored in the field. A single operation may contain more than one procedure
Patient classification (classpat)	This field identifies day cases, ordinary admissions, regular day and regular night attenders
Discharges	
Date of discharge (disdate)	This field contains the date on which the patient was discharged from hospital. It is present in the record only for the last episode of a spell
Destination on discharge (disdest)	This field contains a code that identifies where the patient was due to go on leaving hospital. In most cases patients return home. For many patients the discharge destination is the same as source of admission (<i>admisorc</i>)
Method of discharge (dismeth)	This field contains a code that defines the circumstances under which a patient left hospital. For the majority of patients this is when they are discharged by the consultant. This field is completed only for the last episode in a spell

Data fields	Description
Episodes and spells	
Date episode ended (<i>epiend</i>)	This field contains the date on which a patient left the care of a particular consultant
Date episode started (<i>epistart</i>)	This field contains the date on which a patient was under the care of a particular consultant. If a patient has more than one episode in a spell, for each new episode there is a new value of <i>epistart</i> . However, the admission date that is copied to each new episode in a spell will remain unchanged and will be equal to the episode start date of the first episode in hospital
Episode duration (<i>epidur</i>)	This field contains the difference in days between the episode start date (<i>epistart</i>) and the episode end date (<i>epiend</i>). If the episode is unfinished <i>epidur</i> is set as null
Episode order (<i>epiorder</i>)	This field contains the number of the episode within the current spell. All spells start with an episode where <i>epiorder</i> is 01. Many spells finish with this episode, but if the patient moves to the care of another consultant then a new episode begins. Episode numbers increase by 1 for each new episode until the patient is discharged (this includes transfers to another NHS trust or PCT, i.e. the first episode in the new trust will have <i>epiorder</i> 01). If the same patient returns for a different spell in hospital, <i>epiorder</i> is again set to 01
Episode status (<i>epistat</i>)	This field tells you whether or not the episode had finished before the end of the HES data-year (i.e. whether the episode was still 'live' at midnight on 31 March). Because hospital providers are advised not to include clinical data (diagnosis and operation codes) in unfinished records, these are normally excluded from analyses. Also, if unfinished episodes are included in time series analyses – when data for more than 1 year are involved – there is a danger of counting the same episode twice
HRGs	
HES-generated HRG version (<i>hrg_n.n</i>)	This HES-derived field contains HRG values. HES adds the two most recent versions of HRG codes to records
NHS-generated HRG code (<i>hrgnhs</i>)	The trust-derived HRG value as submitted to SUS takes into account the dominant grouping procedure (<i>domproc</i>) and may differ from the HES-derived HRG (<i>HRG_n.n</i>)
Dominant procedure (<i>domproc</i>)	Contains the dominant procedure (operation) code assigned as part of the (NHS) HRG derivation process and submitted to SUS
Patient	
Age at start of episode (<i>startage</i>)	This derived field, calculated from episode start date (<i>epistart</i>) and date of birth (<i>dob</i>), contains the patient's age in whole years [from 1 to 115 (1990–1 to 1994–5) and from 1 to 120 (1995–6 onwards)]
Patient identifier – HES-generated (<i>pseudo_hesid</i>)	This field uniquely identifies a patient across all data-years. It is generated by matching records for the same patient using a combination of NHS number, local patient identifier, postcode, sex and date of birth
Sex of patient (<i>sex</i>)	This field contains a code that defines the sex of the patient
Socioeconomic	
IMD decile group (<i>md04_decile</i>)	This field uses the IMD overall ranking to identify which 1 of 10 groups a super output area belongs to, from most deprived through to least deprived
System	
SUS record ID (<i>susrecid</i>)	SUS-generated record identifier
ACP, augmented care period; HRG, health-care resource group; ICD-10, <i>International Classification of Diseases, Tenth Edition</i> ; IMD, Index of Multiple Deprivation; OPCS, Office of Population Censuses and Surveys; OPCS-4, <i>OPCS Classification of Interventions and Procedures version 4</i> ; PCT, primary care trust; SUS, Secondary Use Services.	

Hospital Episode Statistics: outpatient

Data fields	Description
Appointments	
Appointment date (apptdate)	The date when an appointment was scheduled
First attendance (firstatt)	Indicates whether a patient is making a first attendance or follow-up attendance, and whether the consultation was face to face or via telephone
Attendance type (atentype)	A field derived from 'first appointment' (<i>firstatt</i>) and 'attended or did not attend' (<i>attended</i>), used to identify if the attendance occurred and whether it was the first or subsequent
Attended or did not attend (attended)	This indicates whether or not a patient attended for an appointment. If the patient did not attend it also indicates whether or not advanced warning was given
Clinical	
Diagnosis (diag_nn)	There are 12 fields (two before April 2007), diag_01 to diag_12, which contain information about a patient's illness or condition. The field diag_01 contains the primary diagnosis. The other fields contain secondary/subsidiary diagnoses. The codes are defined in the <i>International Statistical Classification of Diseases, Injuries and Causes of Death</i>
Main specialty (mainspef)	A code that defines the specialty under which the consultant is contracted. Compare with 'treatment specialty' (<i>tretspef</i>), the specialty under which the consultant worked
Treatment specialty (tretspef)	This field contains a code that defines the specialty in which the consultant was working during the period of care. It can be compared with <i>mainspef</i> , the specialty under which the consultant is contracted. From April 2004, a new list of treatment specialties was introduced (see below). The new list describes the specialised service within which the patient was treated
Medical staff type seeing patient (stafftyp)	Gives information about the type of care professional staff dealing with the patient during a consultant outpatient attendance, or nurse or midwife contact
HRGs	
NHS-generated HRG version no. (hrgnhsvn)	The version number for NHS-generated HRG code (<i>hrgnhs</i>)
NHS-generated HRG code (hrgnhs)	The NHS-generated HRG code takes into account the dominant grouping procedure (<i>domproc</i>) and may differ from the HES-derived HRG (<i>hrgorig</i>)
Patient	
Patient identifier – HES-generated (pseudo_hesid)	This field uniquely identifies a patient across all data-years. It is generated by matching records for the same patient using a combination of NHS number, local patient identifier, postcode, sex and date of birth
Sex of patient (sex)	This field contains a code which defines the sex of the patient
Socioeconomic	
IMD decile group (md04_decile)	This field uses the IMD overall ranking to identify which 1 of 10 groups a super output area belongs to, from most deprived to least deprived
System	
SUS record ID (susrecid)	SUS-generated record identifier
HRG, Healthcare Resource Group; IMD, Index of Multiple Deprivation; SUS, Secondary Use Services.	

Hospital Episode Statistics: accident and emergency

Data fields	Description
Attendances	
Arrival mode (aearrivalmode)	The mode by which a patient arrived at an A&E department
Arrival date (arrivaldate)	The arrival date of a patient in the A&E department
Attendance category (aeattendcat)	An indication of whether a patient is making an initial or follow-up attendance within a particular A&E department: <ol style="list-style-type: none"> 1. first attendance 2. planned follow-up or 3. unplanned follow-up <p>Follow-up always refers to attendance at the same department, and for the same incident as the first attendance</p>
Attendance disposal (aeattendispos)	The way in which an A&E attendance might end
Department type (aedepttype)	A classification of A&E department type according to the activity carried out
Clinical	
A&E diagnosis (diag n)	The A&E diagnosis code recorded for an A&E attendance. The CDS allows an unlimited number of diagnoses to be submitted; however, only the first 12 diagnoses are available within HES. The A&E diagnosis is a six-character code: diagnosis condition (n2), subanalysis (n1), anatomical area (n2) and anatomical side (an1)
A&E investigation (invest n)	The A&E investigation recorded for an A&E attendance. The CDS allows an unlimited number of investigations to be submitted, however, only the first 12 investigations are available within HES. The A&E investigation is a six character code made up of investigation (n2) and local sub-analysis (up to an4). As the subanalysis is for local use, it cannot be classified
A&E treatment (treat n)	The A&E treatment recorded for an A&E attendance. The CDS allows an unlimited number of treatments to be submitted; however, only the first 12 treatments are available within HES. The A&E treatment is a six-character code made up of treatment (n2), subanalysis (n1) and a local use section (up to an3). As the local use section is used for local codes, it cannot be classified
HRGs	
Dominant procedure (domproc)	The procedure that the HRG grouping algorithm has identified as having the greatest effect upon the resources consumed by a patient
Trust HRG value (hrgnhs)	The trust-generated HRG code
Trust HRG version (hrgnhsvn)	The version number for trust-generated HRG code (<i>hrgnhs</i>)
Patient	
Age on arrival (arrivalage)	This derived field, calculated from arrival date and date of birth
Patient identifier – HES generated (pseudo_hesid)	This field uniquely identifies a patient across all data-years. It is generated by matching records for the same patient using a combination of NHS number, local patient identifier, postcode, sex and date of birth
Sex of patient (sex)	This field contains a code which defines the sex of the patient
Residence	
Patient's PCT of residence (respc06)	This derived field contains the code for the PCT for the area in which the patient lived immediately before admission. It is derived from the patient's postcode in the field <i>homeadd</i>
Socioeconomic	
IMD decile group (md04_decile)	This field uses the IMD overall ranking to identify which 1 of 10 groups a super output area belongs to, from most deprived to least deprived

Data fields	Description
System	
Record identifier	This is a record identifier that is created by the system. The eight digits store a decimal number
SUS record ID (susrecid)	SUS-generated record identifier
Treatment	
Health authority of treatment (hatreat)	Health authority of treatment. This field is derived from the hospital provider code (procode). It indicates the health authority within which the treatment took place
PCT of treatment (pcttreat)	PCT of treatment. It is derived from the main site postcode of the hospital provider code (procode), indicating the PCT area within which the organisation that was providing the treatment was located
	Note: (1) The PCT itself may be the provider of the treatment and (2) care provided at subsidiary sites will be attributed to the main trust location
CDS, Commissioning Data Set; IMD, Index of Multiple Deprivation; PCT, primary care trust; SUS, Secondary Use Services.	

Appendix 2 Training documents

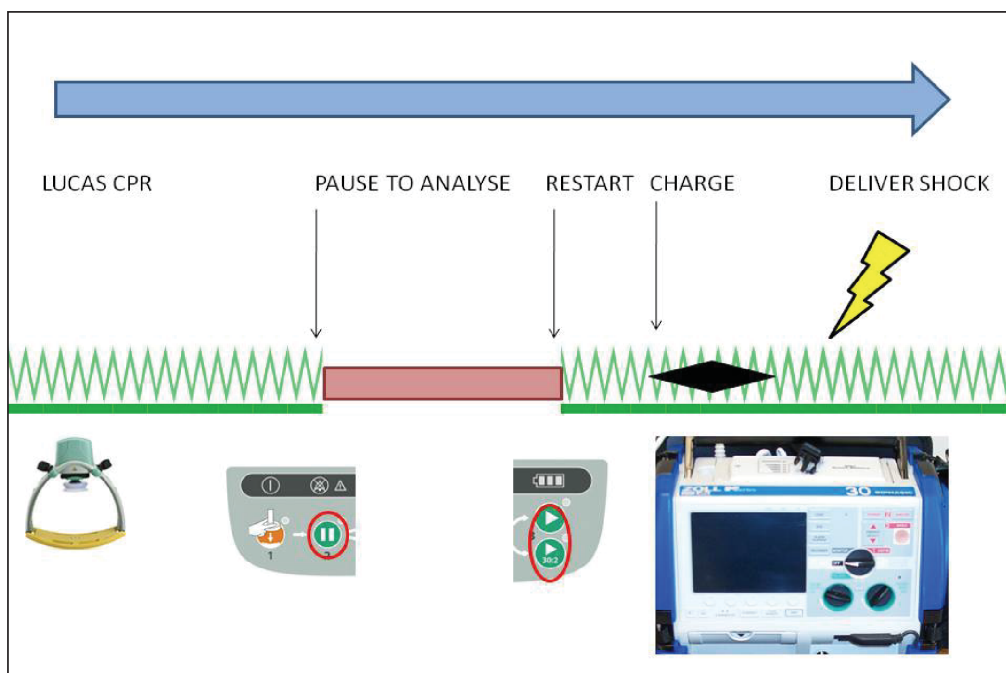
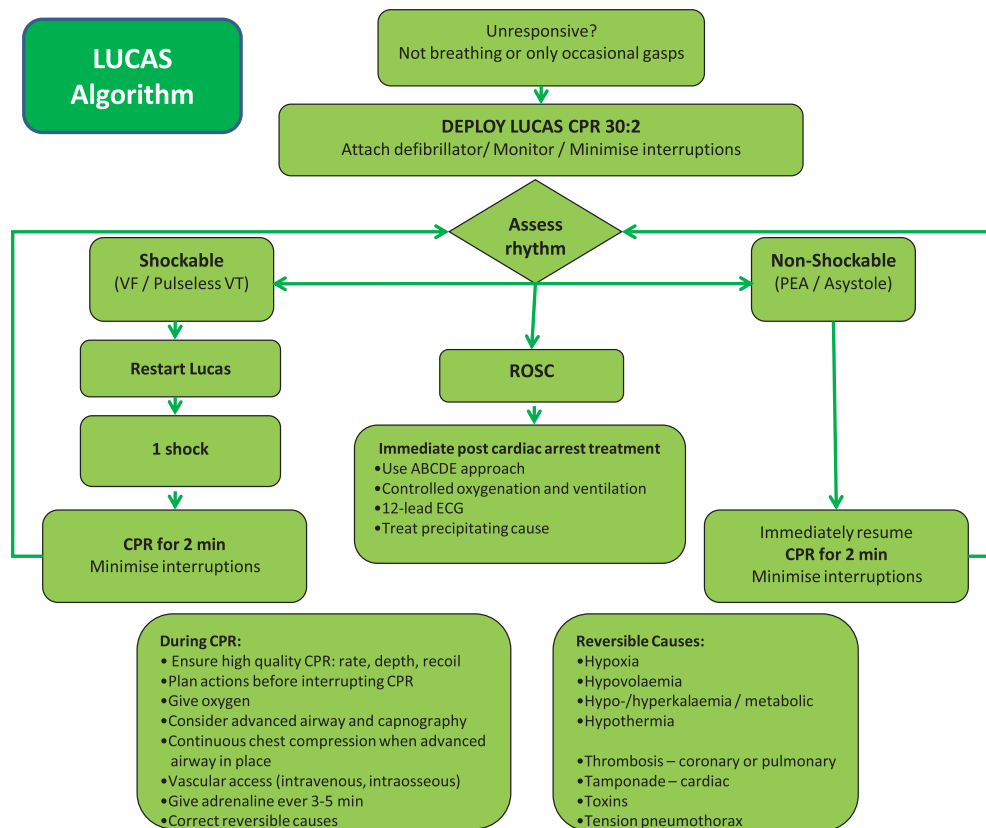



PARAMEDIC TRIAL HELPLINE 02476 XXXXXX

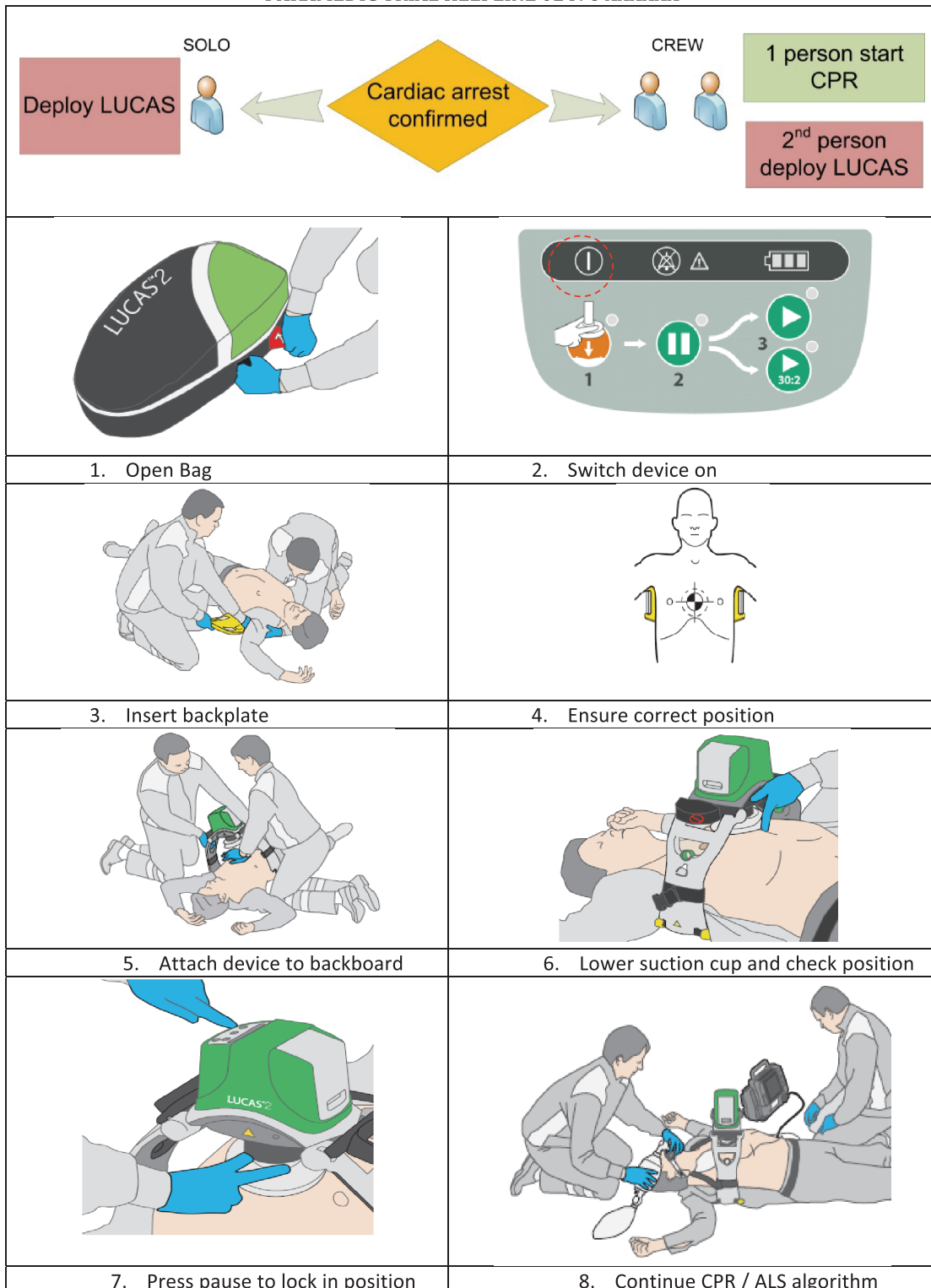

Version 1.1 01/11/2010



LUCAS-2 Competency Assessment

Station _____

Date _____

Number	Element	Achieved
1	Student is able to state the eligibility criteria	
2	Student is able to state the exclusion criteria	
3	Student is able to state the randomisation method	
4	Student opens the bag and pushes ON for one second to start self test	
5	Student positions Back Plate - if part of crew requires cessation of CPR to position Back plate thereafter resumes manual CPR	
6	Student takes the LUCAS from bag, extend legs and ensure claw locks are open by pulling releasing rings.	
7	Student stop compressions & connects the LUCAS to the back plate – nearest side to operator first	
8	Student positions suction cup immediately over end of sternum and ensure it is centered over chest.	
9	Student pushes suction cup to chest with 2 fingers ensuring the pressure pad is in contact with chest & holds in place	
10	With the suction cup still held in place, the student pushes PAUSE to lock in start position	
11	Student confirms correct placement	
12	Student activates LUCAS by pressing either ACTIVE (30:2) OR ACTIVE (continuous compressions)	
13	Student attaches hands free defibrillation pads (ensuring wires are not under suction cup)	
14	Student attaches the stabilisation strap	
15	Student secures arms with wrist straps	
16	After 2 minutes student pauses LUCAS to check rhythm	
17	Student states that if non-shockable then restart LUCAS OR If shockable, restarts LUCAS, charges defibrillator, performs safety checks and delivers shock while LUCAS is running	
18	Student changes suction cup after use	
19	Student describes how to clean LUCAS if contaminated	
20	Student describes how to manage patient records after each case	
21	Student describes what actions are to be taken in the event of an adverse or unexpected event	

Student Name _____

Assessor Name _____

Signature _____

Signature _____

Version 1.1 01/11/2010

PARAVEDIC Trial
Certificate of Completion

is hereby granted to: _____

to certify that they have completed to satisfaction

LUCAS Device Training
for the **PARAVEDIC** Trial

Granted: _____ 2012

Trained by: _____

Warwick
Medical School
CLINICAL TRIALS UNIT

Version 1.1 01/11/2010

Appendix 3 Event reporting



CRF05: Event Form

West Midlands Ambulance Service

March 2012 Version 2.0

Please fax XXXXXXXXXX or email XXXXXXXXXX
within 24hrs of notification of event

Event affecting patient Event affecting crew

1. Event Details (Complete as applicable):							
Date of Event <small>(dd/mm/yyyy)</small>		Device serial No					
Crew IDs/names: Date of cardiac arrest: <small>(dd/mm/yyyy)</small>		Station Name:			Vehicle Call Sign:		
	Case No:				Patient DoB <small>(dd/mm/yyyy)</small>		
2. Description of Event (Please continue on separate sheet as necessary)							
3. Follow up Information							
Resolved? Y <input type="checkbox"/> N <input type="checkbox"/> Date resolved _____							
4. Reason for Reporting (all patients in this trial will be in an immediately life threatening situation; death or hospitalisation is certain. The options below should only be ticked if they were clearly caused by the event.)							
Death						Y <input type="checkbox"/>	N <input type="checkbox"/>
Life-threatening event						Y <input type="checkbox"/>	N <input type="checkbox"/>
In-patient hospitalisation or prolongation of existing hospitalisation						Y <input type="checkbox"/>	N <input type="checkbox"/>
Persistent or significant disability/incapacity						Y <input type="checkbox"/>	N <input type="checkbox"/>
Other medically significant reason for reporting						Y <input type="checkbox"/>	N <input type="checkbox"/>
If other please specify.....							
Notified by (signature) _____				Print Name _____			
Date of Report dd/mm/yyyy _____							
OFFICE USE ONLY							
Event No: _____							
Was the event an ADE		Yes <input type="checkbox"/>	No <input type="checkbox"/>				
Was the event an SADE?		Yes <input type="checkbox"/>	No <input type="checkbox"/>	Was the event related?		Yes <input type="checkbox"/>	No <input type="checkbox"/>
Was the event an Incident?		Yes <input type="checkbox"/>	No <input type="checkbox"/>	Was the event unexpected		Yes <input type="checkbox"/>	No <input type="checkbox"/>
Checked by clinical reviewer: _____				Device Failure?		Yes <input type="checkbox"/>	No <input type="checkbox"/>
Date of review: _____				User error?		Yes <input type="checkbox"/>	No <input type="checkbox"/>

Appendix 4 Case report forms



West Midlands Ambulance Service NHS Trust

CRF 01: Cardiac Arrest Data

For non-trial vehicles only complete shaded boxes

PART 1 – COMPLETE THIS FORM FOR 1st EMERGENCY VEHICLE ON SCENE

Completed from: Paper A3 <input type="checkbox"/> PRF <input type="checkbox"/> Paper A4 <input type="checkbox"/> PRF <input type="checkbox"/> CAD <input type="checkbox"/> E- PRF <input type="checkbox"/>	
Scanned <input type="checkbox"/> A3 PRF <input type="checkbox"/>	
Date of cardiac arrest (dd/mm/yyyy): ____/____/____ Case No: _____ Station: _____	
Call Sign (of 1 st emergency vehicle on scene): _____ LUCAS <input type="checkbox"/> CONTROL <input type="checkbox"/> Non trial vehicle <input type="checkbox"/>	
If other resource 1 st on scene: Bike <input type="checkbox"/> HEMS <input type="checkbox"/> Com 1 st responder <input type="checkbox"/> Unmarked vehicle <input type="checkbox"/> None <input type="checkbox"/>	
999 Call Time <input type="checkbox"/> <input type="checkbox"/> <input type="checkbox"/> <input type="checkbox"/> <input type="checkbox"/> <input type="checkbox"/> (CAD) (24hr) (hh) (mm) (ss)	At Scene Time <input type="checkbox"/> <input type="checkbox"/> <input type="checkbox"/> <input type="checkbox"/> <input type="checkbox"/> <input type="checkbox"/> (CAD) (24hr) (hh) (mm) (ss)
At Patient Time <input type="checkbox"/> <input type="checkbox"/> <input type="checkbox"/> (hh) (mm)	
Please indicate which crew were on the 1 st emergency vehicle on scene, if known:	
Crew name 1: _____ 1 st on scene	Crew name 3: _____ 1 st on scene
Crew name 2: _____ 1 st on scene	Crew name 4: _____ 1 st on scene
1. Key Data a) Resuscitation attempted by EMS: Y <input type="checkbox"/> N <input type="checkbox"/> <i>(1st vehicle on scene)</i> If no: i) Incompatible with life Y <input type="checkbox"/> N <input type="checkbox"/> ii) DNAR or expected death Y <input type="checkbox"/> N <input type="checkbox"/> iii) Futility (>15mns since collapse + no bystander CPR + asystole >30s) Y <input type="checkbox"/> N <input type="checkbox"/> b) Patient presumed ≥18: Y <input type="checkbox"/> N <input type="checkbox"/> c) DOB: ____/____/____ or Unknown <input type="checkbox"/> (dd) (mm) (yyyy) i) If unknown - approx. age: d) Female <input type="checkbox"/> Male <input type="checkbox"/> e) Patient believed: Not pregnant <input type="checkbox"/> Pregnant <input type="checkbox"/>	2. Aetiology (tick one only) Presumed Cardiac <input type="checkbox"/> Traumatic <input type="checkbox"/> Respiratory <input type="checkbox"/> Submersion <input type="checkbox"/> Unknown* <input type="checkbox"/> Other* (non cardiac) <input type="checkbox"/> *Specify: _____ 3. Location Home <input type="checkbox"/> Public place <input type="checkbox"/> Other* <input type="checkbox"/> *Specify (e.g. Ambulance, Friend's house): _____
4. Witness/Bystander a) Witnessed: Y <input type="checkbox"/> N <input type="checkbox"/> Unknown <input type="checkbox"/> If yes: Bystander <input type="checkbox"/> EMS <input type="checkbox"/> Non EMS healthcare <input type="checkbox"/> b) Bystander CPR before EMS arrival: <i>(general public, GP/nurse, off duty health care)</i> Y <input type="checkbox"/> N <input type="checkbox"/> Unknown <input type="checkbox"/> c) Defib before EMS arrival: Y <input type="checkbox"/> N <input type="checkbox"/> Unknown <input type="checkbox"/>	
PART 2 – ONLY COMPLETE IF PATIENT IS ELIGIBLE	
5. Compliance LUCAS used: Y <input type="checkbox"/> N <input type="checkbox"/> If no: TBC <input type="checkbox"/> Protocol confusion* <input type="checkbox"/> Patient too big <input type="checkbox"/> Other* <input type="checkbox"/> Not trained <input type="checkbox"/> Crew decision* <input type="checkbox"/> Patient too small <input type="checkbox"/> *Specify: _____ (select only one) Forgot <input type="checkbox"/> No device* <input type="checkbox"/> Device failure* <input type="checkbox"/>	
6. Resuscitation Information a) Initial rhythm: VF <input type="checkbox"/> VT <input type="checkbox"/> PEA <input type="checkbox"/> Asystole <input type="checkbox"/> Unknown <input type="checkbox"/> b) Drugs given (for CA): Y <input type="checkbox"/> N <input type="checkbox"/> Unknown <input type="checkbox"/> c) Intubated <input type="checkbox"/> (successfully): Y <input type="checkbox"/> N <input type="checkbox"/> Unknown <input type="checkbox"/> d) LMA/Supraglottic device (successfully): Y <input type="checkbox"/> N <input type="checkbox"/> Unknown <input type="checkbox"/>	
7. Outcomes a) ROSC at any time: Y <input type="checkbox"/> N <input type="checkbox"/> Unknown <input type="checkbox"/> b) Transported to Hospital (with CPR/ROSC): Y <input type="checkbox"/> N (deceased) <input type="checkbox"/> i) If no - CPR stopped at hh/mm (24hr) : <input type="checkbox"/> <input type="checkbox"/> <input type="checkbox"/> <input type="checkbox"/> ii) If yes - Time Left Scene hh/mm/ss (24hr) <input type="checkbox"/> <input type="checkbox"/> <input type="checkbox"/> <input type="checkbox"/> <input type="checkbox"/> <input type="checkbox"/> <i>(transporting vehicle) (CAD)</i> iii) Hospital name: _____ iv) Destination time (CAD) hh/mm/ss (24hr) <input type="checkbox"/> <input type="checkbox"/> <input type="checkbox"/> <input type="checkbox"/> <input type="checkbox"/> <input type="checkbox"/> <i>(transporting vehicle)</i> v) Handover time hh/mm (24hr) <input type="checkbox"/> <input type="checkbox"/> <input type="checkbox"/> <input type="checkbox"/> <i>(transporting vehicle)</i> vi) Status at handover: ROSC <input type="checkbox"/> CPR in progress <input type="checkbox"/> Unknown <input type="checkbox"/> vii) Patient declared deceased by ED staff: Y <input type="checkbox"/> N (complete CRF02) <input type="checkbox"/> Unknown (complete CRF02) <input type="checkbox"/>	
8. Comments	

Completed by: _____ Date (dd/mm/yyyy): ____/____/____

**CRF 02: Follow up of Cardiac Arrest**

Complete for Eligible Transports to Hospital Only

1. Date of cardiac arrest (dd/mm/yyyy): ___/___/___		Case No: _____	Station: _____
2. Patient Details Not known <input type="checkbox"/>			
First names: _____		Last name: _____	
Address: _____			
Postcode: _____		NHS No (from SCR): <input type="checkbox"/> <input type="checkbox"/> <input type="checkbox"/> <input type="checkbox"/> <input type="checkbox"/> <input type="checkbox"/> <input type="checkbox"/> <input type="checkbox"/> <input type="checkbox"/> <input type="checkbox"/> <input type="checkbox"/>	
Checks to make:			
3. Date SCR checked (dd/mm/yyyy):			
1. ___/___/___	Record found? YES <input type="checkbox"/>	NO <input type="checkbox"/>	
2. ___/___/___	Record found? YES <input type="checkbox"/>	NO <input type="checkbox"/>	
4. GP Details known? YES <input type="checkbox"/> NO <input type="checkbox"/>			
GP name: _____		Surgery name: _____	
GP address: _____		Post code: _____	
GP phone number: _____		Date of GP contact (dd/mm/yyyy): ___/___/___	
5. Date registrar contacted (dd/mm/yyyy): 1. ___/___/___ 2. ___/___/___ Not checked <input type="checkbox"/>			
6. Date hospital contacted (dd/mm/yyyy): 1. ___/___/___ 2. ___/___/___ Not checked <input type="checkbox"/>			
7. Date of discharge from hospital: ___/___/___		Date of discharge from ICU: ___/___/___	
Discharged to: Home		Nursing/residential home	Rehab facility
Other _____			
Address: _____		Post code: _____	
<small>(other than home)</small>			
8. MRIS (WCTU only) - Date of upload onto MRIS (dd/mm/yyyy): ___/___/___			
Outcome:			
9. Death recorded? YES <input type="checkbox"/> NO <input type="checkbox"/>			
If yes, date of death (dd/mm/yyyy): ___/___/___		Unknown <input type="checkbox"/>	
Location of death: Unknown <input type="checkbox"/> Hospital <input type="checkbox"/> Home <input type="checkbox"/> Other <input type="checkbox"/>		Specify: _____	
Source: SCR <input type="checkbox"/> GP <input type="checkbox"/> Registrar <input type="checkbox"/> Hospital <input type="checkbox"/> MRIS <input type="checkbox"/> Other <input type="checkbox"/>		Specify: _____	
<small>(Tick all that apply)</small>			
If "No death recorded", send information sheet 1 (invite letter):			
10. Date information sheet 1 sent (dd/mm/yyyy): ___/___/___			
Date reply received (dd/mm/yyyy): ___/___/___		Type of reply: Post <input type="checkbox"/> Phone <input type="checkbox"/> Email <input type="checkbox"/>	
If no reply within 14 days: write <input type="checkbox"/> call <input type="checkbox"/> patient			
11. Date of 2nd contact (dd/mm/yyyy): ___/___/___			
Date reply received (dd/mm/yyyy): ___/___/___		Type of reply: Post <input type="checkbox"/> Phone <input type="checkbox"/> Email <input type="checkbox"/>	
12. Comments (record details of phone conversation): _____			

13. If no reply within 14 days, action taken: Contact GP <input type="checkbox"/> SCR check <input type="checkbox"/> Registrar <input type="checkbox"/> Phone patient <input type="checkbox"/>			
Date (dd/mm/yyyy): ___/___/___		Response: _____	
14. Consultee required? (If YES, complete CRF07) YES <input type="checkbox"/> NO <input type="checkbox"/> Unknown <input type="checkbox"/>			

Completed by: _____ Date (dd/mm/yyyy): ___/___/___

Appendix 5 Three-month follow-up questionnaires



PARAMEDIC – Prehospital Randomised Assessment of a Mechanical Compression Device in Cardiac Arrest

Region:

TNO:

3 Month Follow Up Assessment

For assistance with completing this booklet please contact the PARAMEDIC team on: or

Please read the instructions in this booklet carefully



Warwick
Medical School
CLINICAL TRIALS UNIT

ICRCTN: 08233942

July 2012

POCKET FOR SELF ADDRESSED ENVELOPES

WRITING SHIELD

WRITING SHIELD

Instructions for entering data in this booklet

Write legibly in **black** or **blue** ink using a ball-point pen

When completing the forms please insert the writing shield behind the **yellow** copy of the form to avoid marking consecutive pages.

Please enter the Region & TNO at the top of every page. The TNO is a unique, computer generated ID number for each

participant and will be given to you by the Trial Coordinating Centre.

Please ensure that ALL questions are answered as instructed

Where there are boxes put a cross in the relevant box to indicate your response

Where you are required to write a response please write legibly in BLOCK CAPITALS

Enter only one response for each item (unless otherwise specified)

Corrections

If corrections to data entered on the form are needed, draw a single line through the incorrect entry (do not obscure the original entry) and write the correct data next to the erroneous data, initial and date.

Corrections must be dated and initialled by the person making the change

Please DO NOT cover the original data by any method

Please DO NOT erase incorrect responses

Please DO NOT use correction fluid

Please DO NOT make corrections by overwriting an entry

If data are missing, this should be explained on the relevant form, for example by means of the statement “not done”, “unknown”

After each visit (at 3 months and at 12 months) please:

- ◆ Remove all top copy forms for the given time-point (**WHITE**)
- ◆ Return these to the PARAMEDIC office using a large freepost envelope
- ◆ File duplicate (**yellow**) copies at site as per local guidelines

Informed consent

Please ensure that the correct consent form / agreement form is also completed and send to Warwick Clinical Trials Unit (separate to the questionnaires), site should keep a copy, copy should be sent to patient for their records.

3 month assessment checklist

Please tick only one box per questionnaire.

Ideally all questionnaires should be completed by patient (self-administered).

If administered by researcher (for example, because the patient has poor eye sight, is illiterate or is unable to write because of any physical handicap), the questions should be read aloud exactly as they appear on the questionnaires and the patient's exact answer used. Do not prompt patient or answer on their behalf.

If patient representative responds on patient's behalf, tick Proxy Assessment. If administered over the phone or by post then tick relevant box.

Cerebral Performance Categories Scale (CPC Score)

CPC 1 = Good cerebral performance: conscious, alert, able to work, might have mild neurologic or psychologic deficit.

CPC 2 = Moderate cerebral disability: conscious, sufficient cerebral function for independent activities of daily life. Able to work in sheltered environment.

CPC 3 = Severe cerebral disability: conscious, dependent on others for daily support because of impaired brain function. Ranges from ambulatory state to severe dementia or paralysis.

CPC 4 = Coma or vegetative state: any degree of coma without the presence of all brain death criteria. Unawareness, even if appears awake (vegetative state) without interaction with environment; may have spontaneous eye opening and sleep/awake cycles. Cerebral unresponsiveness.

(Safar P. Resuscitation after Brain Ischemia, in Grenvik A and Safar P Eds: Brain Failure and Resuscitation, Churchill Livingstone, New York, 1981; 155 – 184).

Region:

--	--	--	--

TNO:

--	--	--	--

To be completed by researcher conducting patient assessment.

Please place a cross in the appropriate box

Date of 3 Month Assessment

--	--

Day

--	--

Month

--	--	--	--

Year**YES****NO****Has the patient willingly given written informed consent?**If No:

Has a patient representative willingly given written informed agreement?

Has Form 07 been completed (consultee information)?

3 month assessment checklist

	Self Administered	Administered by researcher	Proxy assessment	Administered over phone	Completed by Post
EQ5D					
SF-12					
3 month Health Economics					

CPC Score:1 2 3 4 Has researcher remained blinded? Yes No

If No, when did unblinding occur? _____

Name of person conducting 3 month assessment (please print): _____

Signature of person conducting 3 month assessment: _____

3month checklist

The remaining forms are to be filled in by the participant with help from the researcher if needed, following completion of the consent process.

Questionnaire Instructions for Participants

- ◆ Please insert the writing shield behind the **YELLOW** copy of **each** form to avoid marking consecutive pages.
 - ◆ Please read these instructions before completing the questionnaires.
 - ◆ Please follow the instructions for each section carefully.
 - ◆ Please answer **ALL** the questions. Although it may seem that the questions are asked more than once, it is still important that you answer every one.
 - ◆ Please only enter one response for each item (unless otherwise specified).
-
- ◆ Please use a **BLACK** or **BLUE** pen. Please do not use a pencil.
 - ◆ Please check that you have completed all sections.
 - ◆ If you make a mistake draw a single line through the incorrect entry, initial and date and add correct answer next to the incorrect entry.
 - ◆ Please **DO NOT** use correction fluid

Questionnaire instructions for Participants

Region: **TNO:**

By placing a tick in one box in each group below, please indicate which statements best describe your own health state today.

Mobility

- I have no problems in walking about
- I have some problems in walking about
- I am confined to bed

Self-Care

- I have no problems with self-care
- I have some problems washing or dressing myself
- I am unable to wash or dress myself

Usual Activities (e.g. work, study, housework, family or leisure activities)

- I have no problems with performing my usual activities
- I have some problems with performing my usual activities
- I am unable to perform my usual activities

Pain/Discomfort

- I have no pain or discomfort
- I have moderate pain or discomfort
- I have extreme pain or discomfort

Anxiety/Depression

- I am not anxious or depressed
- I am moderately anxious or depressed
- I am extremely anxious or depressed

© EuroQoL Group 1990 EQ5D

Region: TNO:

To help people say how good or bad a health state is, we have drawn a scale (rather like a thermometer) on which the best state you can imagine is marked 100 and the worst state you can imagine is marked 0.

We would like you to indicate on this scale how good or bad your own health is today, in your opinion. Please do this by drawing a line from the box below to whichever point on the scale indicates how good or bad your health state is today.

**Your own
health state
today**

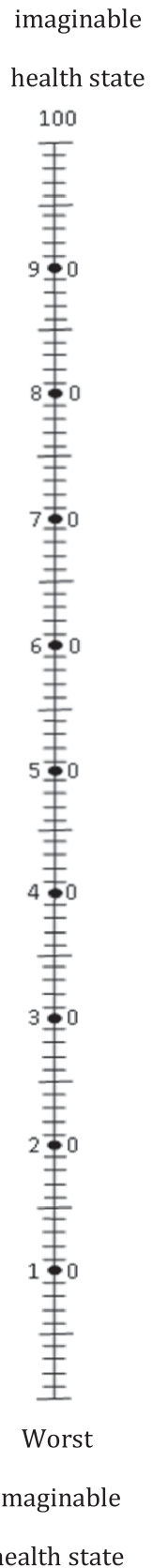

SF-12 forms have been redacted for copyright reasons.

Region: **TNO:**

1. Immediately following your cardiac arrest how many days did you spend in hospital?

Type of ward	Total number of days
Intensive care unit	
Cardiac care unit	
General ward	

2. Since that time have you used any of the following hospital based or residential care services (for example, have you been admitted to hospital again or had an outpatient clinic appointment)?

Type of service	Which service have you used since your cardiac arrest? Please tick (✓) yes or no		Total number of days spent in hospital/convalescent or nursing home since your cardiac arrest	Total number of visits since your cardiac arrest
	Yes	No		
Hospital inpatient stay (in addition to your stay reported in question 1)	Yes	No		
Hospital outpatient clinic	Yes	No		
Hospital accident and emergency department	Yes	No		
Nursing/residential home	Yes	No		
Other (please specify)	Yes	No		

Region: **TNO:**

Type of service	Have you used the service since your cardiac arrest? Please tick (✓) yes or no		Total number of face to face contacts during the time since your cardiac arrest
a. GP, surgery visit	Yes	No	
b. GP, home visit	Yes	No	
c. District nurse, health visitor or member of community health team	Yes	No	
d. Social worker	Yes	No	
e. Counsellor	Yes	No	
f. Home help or care worker	Yes	No	
g. Speech and language therapist	Yes	No	
h. Psychiatrist or psychologist	Yes	No	
i. Day centre	Yes	No	
j. Lunch or social club (organised by health or social care providers)	Yes	No	
k. Food, medicine or laundry delivery service (organised by health or social care providers)	Yes	No	
l. Family or patient support or self help groups	Yes	No	
m. Other (please specify, for example have you had any telephone consultations with your GP):	Yes	No	

3 month Health Economics

Version 3 October

***Thank you for
completing these
questions!***

Please return this booklet to the researcher.

ICRCTN: 08233942

January 2012



PARAMEDIC Trial Team

**Clinical Trials Unit
Warwick Medical School
University of Warwick
Gibbet Hill Campus
Coventry
CV4 7AL**

Telephone: [REDACTED]

Fax: [REDACTED]

Appendix 6 Twelve-month follow-up questionnaires



PARAMEDIC – Prehospital Randomised Assessment of a Mechanical Compression Device in Cardiac Arrest

Region:

TNO:

12 Month Follow Up Assessment

For assistance with completing this booklet please contact the PARAMEDIC team on: or

Please read the instructions in this booklet carefully



ICRCTN: 08233942

Warwick
Medical School
 CLINICAL TRIALS UNIT

Dec 2012

POCKET FOR SELF ADDRESSED ENVELOPES

WRITING SHIELD

WRITING SHIELD

Instructions for entering data in this booklet

Write legibly in **black** or **blue** ink using a ball-point pen

When completing the forms please insert the writing shield behind the **pink** copy of the form to avoid marking consecutive pages.

Please enter the Region & TNO at the top of every page. The TNO is a unique, computer generated ID number for each

participant and will be given to you by the Trial Coordinating Centre.

Please ensure that ALL questions are answered as instructed

Where there are boxes put a cross in the relevant box to indicate your response

Where you are required to write a response please write legibly in BLOCK CAPITALS

Enter only one response for each item (unless otherwise specified)

Corrections

If corrections to data entered on the form are needed, draw a single line through the incorrect entry (do not obscure the original entry) and write the correct data next to the erroneous data, initial and date.

Corrections must be dated and initialled by the person making the change

Please DO NOT cover the original data by any method

Please DO NOT erase incorrect responses

Please DO NOT use correction fluid

Please DO NOT make corrections by overwriting an entry

If data are missing, this should be explained on the relevant form, for example by means of the statement “not done”, “unknown”

After each visit (at 3 months and at 12 months) please:

- ◆ Remove all top copy forms for the given time-point (**WHITE**)
- ◆ Return these to the PARAMEDIC office using a large freepost envelope
- ◆ File duplicate copies (**pink**) at site as per local guidelines

Informed consent

Please ensure that the correct consent form / agreement form is also completed and send to Warwick Clinical Trials Unit (separate to the questionnaires), site should keep a copy, copy should be sent to patient for their records.

12 month assessment checklist

Please tick only one box per questionnaire.

Ideally all questionnaires should be completed by patient (self-administered).

If administered by researcher (for example, because the patient has poor eye sight, is illiterate or is unable to write because of any physical handicap), the questions should be read aloud exactly as they appear on the questionnaires and the patient's exact answer used. Do not prompt patient or answer on their behalf.

If patient representative responds on patient's behalf, tick Proxy Assessment. If administered over the phone or by post then tick relevant box.

Region: **TNO:**

To be completed by researcher conducting patient assessment.

Please place a cross in the appropriate box

Date of 12 Month Assessment

Day **Month** **Year**

	YES	NO
Was consent received at 3 month assessment? <u>If No:</u>	<input type="checkbox"/>	<input type="checkbox"/>
Has patient willingly given written informed consent? <u>If No:</u>	<input type="checkbox"/>	<input type="checkbox"/>
Has a patient representative willingly given written informed agreement?	<input type="checkbox"/>	<input type="checkbox"/>
Has Form 07 been completed (consultee information)?	<input type="checkbox"/>	<input type="checkbox"/>

12 month assessment checklist

	Self Administered	Administered by researcher	Proxy assessment	Administered over phone	Completed by Post
EQ5D					
SF-12					
HADS					
PTSD					
12 month Health Economics MMSE					

Has researcher remained blinded? Yes No

If No, when did unblinding occur? _____

Name of person conducting 12 month assessment (please print): _____

Signature of person conducting 12 month assessment: _____

3month checklist

The remaining forms are to be filled in by the participant with help from the researcher if needed, following completion of the consent process.

Questionnaire Instructions for Participants

- ◆ Please insert the writing shield behind the **PINK** copy of **each** form to avoid marking consecutive pages.
 - ◆ Please read these instructions before completing the questionnaires.
 - ◆ Please follow the instructions for each section carefully.
 - ◆ Please answer **ALL** the questions. Although it may seem that the questions are asked more than once, it is still important that you answer every one.
 - ◆ Please only enter one response for each item (unless otherwise specified).
-
- ◆ Please use a **BLACK** or **BLUE** pen. Please do not use a pencil.
 - ◆ Please check that you have completed all sections.
 - ◆ If you make a mistake draw a single line through the incorrect entry, initial and date and add correct answer next to the incorrect entry.
 - ◆ Please **DO NOT** use correction fluid

Questionnaire instructions for
Participants

Region: **TNO:**

By placing a tick in one box in each group below, please indicate which statements best describe your own health state today.

Mobility

- I have no problems in walking about
- I have some problems in walking about
- I am confined to bed

Self-Care

- I have no problems with self-care
- I have some problems washing or dressing myself
- I am unable to wash or dress myself

Usual Activities (e.g. work, study, housework, family or leisure activities)

- I have no problems with performing my usual activities
- I have some problems with performing my usual activities
- I am unable to perform my usual activities

Pain/Discomfort

- I have no pain or discomfort
- I have moderate pain or discomfort
- I have extreme pain or discomfort

Anxiety/Depression

- I am not anxious or depressed
- I am moderately anxious or depressed
- I am extremely anxious or depressed

© EuroQoL Group 1990 EQ5D

Region: **TNO:**

To help people say how good or bad a health state is, we have drawn a scale (rather like a thermometer) on which the best state you can imagine is marked 100 and the worst state you can imagine is marked 0.

We would like you to indicate on this scale how good or bad your own health is today, in your opinion. Please do this by drawing a line from the box below to whichever point on the scale indicates how good or bad your health state is today.

**Your own
health state
today**

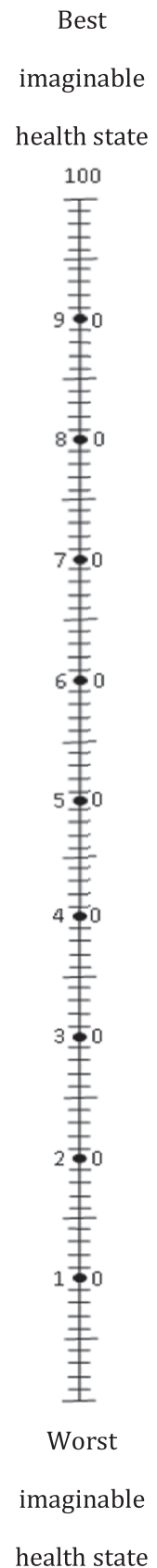

SF-12 forms have been redacted for copyright reasons.

HADS forms have been redacted for copyright reasons.

Region: TNO:

PTSD Checklist – Civilian Version (PCL-C)

Instruction to patient: Below is a list of problems and complaints that veterans sometimes have in response to stressful life experiences. Please read each one carefully, put an "X" in the box to indicate how much you have been bothered by that problem *in the last month*.

No.	Response	Not at all (1)	A little bit (2)	Moderately (3)	Quite a bit (4)	Extremely (5)
1	Repeated, disturbing <i>memories, thoughts, or images</i> of a stressful experience from the past?					
2	Repeated, disturbing <i>dreams</i> of a stressful experience from the past?					
3	Suddenly <i>acting or feeling</i> as if a stressful experience <i>were happening</i> again (as if you were reliving it)?					
4	Feeling <i>very upset</i> when <i>something reminded</i> you of a stressful experience from the past?					
5	Having <i>physical reactions</i> (e.g., heart pounding, trouble breathing, or sweating) when <i>something reminded</i> you of a stressful experience from the past?					
6	Avoid <i>thinking about</i> or <i>talking about</i> a stressful experience from the past or avoid <i>having feelings</i> related to it?					
7	Avoid <i>activities</i> or <i>situations</i> because they <i>remind you</i> of a stressful experience from the past?					
8	Trouble <i>remembering important parts</i> of a stressful experience from the past?					
9	Loss of <i>interest in things that you used to enjoy</i> ?					
10	Feeling <i>distant</i> or <i>cut off</i> from other people?					
11	Feeling <i>emotionally numb</i> or being unable to have loving feelings for those close to you?					
12	Feeling as if your <i>future</i> will somehow be <i>cut short</i> ?					
13	Trouble <i>falling</i> or <i>staying asleep</i> ?					
14	Feeling <i>irritable</i> or having <i>angry outbursts</i> ?					
15	Having <i>difficulty concentrating</i> ?					
16	Being " <i>super alert</i> " or watchful on guard?					
17	Feeling <i>jumpy</i> or easily startled?					

PCL-M for DSM-IV (11/1/94) Weathers, Litz, Huska, & Keane National Center for PTSD - Behavioral Science Division

This is a Government document in the public domain.

PTSD

Region: TNO:

1. Over the *last three months* have you used any of the following hospital based or residential care services (for example, have you been admitted to hospital or had an outpatient clinic appointment)?

Type of service	Which service have you used in the last three months? Please tick (✓) yes or no		Total number of days spent in hospital/convalescent or nursing home in the last three months	Total number of visits in the last three months
	Yes	No		
Hospital inpatient stay	Yes	No		
Hospital outpatient clinic	Yes	No		
Hospital accident and emergency department	Yes	No		
Nursing/residential home	Yes	No		
Other (please specify)	Yes	No		

12 month Health Economics

Region: TNO:

2. Over the *last three months* have you used any of the following *community* based health and social services (this includes any services that are not within the hospital for example, visits to the GP)?

Type of service	Have you used the service in the last three months? Please tick (✓) yes or no		Total number of face to face contacts over the last three months
	Yes	No	
a. GP, surgery visit	Yes	No	
b. GP, home visit	Yes	No	
c. District nurse, health visitor or member of community health team	Yes	No	
d. Social worker	Yes	No	
e. Counsellor	Yes	No	
f. Home help or care worker	Yes	No	
g. Speech and language therapist	Yes	No	
h. Psychiatrist or psychologist	Yes	No	
i. Day centre	Yes	No	
j. Lunch or social club (organised by health or social care providers)	Yes	No	
k. Food, medicine or laundry delivery service (organised by health or social care providers)	Yes	No	
l. Family or patient support or self help groups	Yes	No	
m. Other (please specify, for example have you had any telephone consultations with your GP):	Yes	No	

12 month Health Economics

***Thank you for
completing these
questions!***

Please return this booklet to the researcher.

MMSE forms have been redacted for copyright reasons.



PARAMEDIC Trial Team

**Clinical Trials Unit
Warwick Medical School
University of Warwick
Gibbet Hill Campus
Coventry
CV4 7AL**

Telephone: [REDACTED]

Fax: [REDACTED]

Appendix 7 Data management plan



PARAMEDIC Data Management and Monitoring Plan

Prepared by

Name and role: Jessica Horton, Clinical Trial Coordinator
Charlotte Kaye, Trainee Clinical Trial Coordinator

Signature:

Date:

Approved by

Name and role: Simon Gates, Chief Investigator

Signature:

Date:

This data management and monitoring plan will be used in accordance with:

- WCTU SOP 15 (Data Management)
- WCTU SOP 18 (Risk Assessment and Monitoring)
- WCTU SOP 30 (Electronic Data Security)
- PARAMEDIC Statistical Analysis Plan

Aims: To outline data entry, data cleaning, data checking and monitoring procedures at WCTU and Sites.

To check that data entry error rate for the primary outcome is $\leq 1\%$ and for the secondary outcome/for all other variables is $\leq 5\%$

Also to determine inaccurate, incomplete or unreasonable data and then improve the quality through correction of detected errors and omissions. This will include format checks, completeness checks, logic checks, limit checks, review of the data to identify outliers or other errors, and assessment of data in primary and secondary outcomes.

Where errors are found, data will be corrected and staff will be retrained as needed.

This plan is divided into three parts:

- 1. Data entry**
- 2. Data cleaning, data checking and monitoring at WCTU**
- 3. Data checking (Source Data Verification) and monitoring at Sites**



Data entry

Please refer to the following files for the most up-to-date Data Collection and Data Entry procedures:
<M:\Emergency Care Trials\PARAMEDIC\PlansProcessesIssues\PARAMEDIC CTU Manual\8. Data collection>

-Working Procedure Data entry_CRF01 and CRF02

-Working Procedure Data entry_Follow Up

-Working Procedure Research Fellows



2. Data Cleaning, data checking and monitoring at WCTU

All data checking will be undertaken by a person who did not originally enter the data. Data cleaning includes checking for missing data, data queries, monthly/quarterly data checks and validation checks. This cleaning will be done prior to data checking (as per SOP 15).

2.1 New Data Clerks

For new Data Entry Clerks working on the trial the TC will perform a 100% data check of the first 50 CRFs entered (to include a mix of different cases i.e eligible, non-trial vehicle, non resusc, excluded). Any errors will be discussed with the Data Entry Clerk and further training will be given if required, and corrected on the database.

2.2 Checks during Data Entry

As data is entered, any missing data fields or confusing information is added to the individual Trust query lists straight away - see data query procedure in [M:\Emergency Care Trials\PARAMEDIC\Plans, processes, issues\PARAMEDIC CTU Manual_In Progress\8. Data collection\Working Procedure Data entry](#)

This is emailed to Research Fellows/Officers at each ambulance service every 2 weeks. The Data Clerk will highlight on the CRF, with post-it notes, the information that needs to be queried with the Research Fellow/Officer. Once the information has been obtained/clarified the post-it note will be removed and the database and CRF will be amended as appropriate. Changes to CRF's are made in a different coloured pen, initialled and dated.

Reports detailing cases where LUCAS was not used in the LUCAS arm are sent to the research fellows at the beginning of each month automatically from the database. The research fellows then follow up with crews involved to find out the reason for non use. Reports are also sent where LUCAS used is blank (control and LUCAs arm) to find out from crews if it was used or not.

2.3 Checks on entered data for CRF01

Before the end of recruitment, data on paper CRFs will be checked by someone in the trial team other than the person who entered the data, against data entered on the database. This is specifically to check for errors which could result in:

- misclassification of eligibility
- errors relating to the primary/secondary outcomes

Only data from eligible participants will be checked, due to the large amount of data collected. 10% of eligible cases per ambulance service will be randomly selected (using the RAND function in Excel), and all fields on CRF01 will be checked for data entry validation. The number of fields that are completed on each CRF01 vary according to patient scenario, therefore error rates will be calculated based on how many fields should have been completed for each case.



An Excel spread sheet has been set up to record errors and calculate error rates for these scenarios.

<<spreadsheet and link here>>

It should be noted that Q7b and Q7bvii relate to the primary outcome for the patient, therefore once the 10% of cases have been checked a further calculation of error for these two fields will be made which should not exceed 1%. If it does, then a further 10% of cases will be selected and only these two fields will be checked. If the error rate is still >1% once 20% have cases have been checked, the TMG will discuss further actions.

For data not relating to the primary outcome: If there is >5% error in data entry for the 10% of cases checked, a further 10% of cases will be selected for all fields to be checked. If the error rate is still >5% this will again be discussed by the TMG.

2.3.1 On-going Quarterly logic/data checks

The following data queries are also run monthly through a query report in reporting tool (PARAMEDIC/Data Queries/Quarterly checks).

- Where 'identified through' is blank
- If other resource 1st on scene, check who witnessed arrest and whether CPR/defib given
- Cases where bystander CPR was given but not resuscitated by EMS
- Check stations and start dates
- Cases where patient declared deceased at ED but no comments (death is usually confirmed in comments)
- Consistency of hospital names
- Review of non compliance reasons to be re-categorised
- Review of comments for eligible and non-eligible cases (to detect DNARS, futility and rigor mortis cases, mortal staining, trauma, ROSC before EMS arrival, short resusc, in-hospital which should be excluded)
- Where initial rhythm is 'unknown'
- Cases where arrest was witnessed but no bystander CPR given

If any queries arise these are added to the query list and dealt with as per procedure for handling data queries (See [M:\Emergency Care Trials\PARAMEDIC\PlansProcessesIssues\PARAMEDIC CTU Manual\8. Data collection\](#))

2.3.2 On-going Monthly logic/data checks

The following data queries are also run monthly through a query report in reporting tool (PARAMEDIC/Data Queries/Monthly checks).

- Where 'at scene' and 'at patient' times are missing
- Where patient 'gender' is blank
- Where 'location' is blank
- Where location of arrest is 'ambulance' will check station is correct
- Where location of arrest is 'ambulance' and 'witnessed by EMS?' is blank
- Where reason for no resuscitation is missing (ineligible cases only)



- Where resuscitation information is missing (Rhythm, Drugs, Intubated, LMA)
- Where 'other resource 1st on scene?' is blank
- Where 'bystander CPR before EMS arrival' is blank
- Where 'witnessed' is blank
- Where 'witnessed by bystander/EMS/non-EMS' is blank
- Where 'defib before EMS arrival' is blank
- Where 'CPR stop time' is missing
- Where destination and handover times are missing
- Where marked as 'ineligible' but case was eligible
- Where 'rhythm' is blank
- Check status deceased but death recorded is blank

If any queries arise these are added to the query list and dealt with as per procedure for handling data queries (See [M:\Emergency Care Trials\PARAMEDIC\PlansProcessesIssues\PARAMEDIC CTU Manual\8. Data collection\](#))

A log will be kept of cases where data will never be known such as gender, times (e.g CPR stop time).

At the end of the recruitment aetiology other and location other will be reviewed and re-categorised if needed. Aetiology will be reviewed by a clinical person.

2.4 Checks on data entered on database for CRF02

2.4.1 Primary Outcome

The primary outcome (see table 1) is checked by several sources (MRIS, GP, SCR, Hospital) and therefore does not require further source verification checks. 100% of the information returned by MRIS is cross checked against the database. Before the end of recruitment we will double check 10% of cases matched on MRIS for data entry errors, to make sure Date of Death matches the database.

Some notes to be aware of when checking data entry for CRF02:

- Death information will come in from multiple sources. If data from MRIS clashes with existing data i.e DOB, gender, then go with existing data (after double checking paper CRF02 and source data). If MRIS provides additional information i.e DOB, NHS number when it was missing in the database, this information should be used. If there is a discrepancy between the date of death from MRIS or the SCR then the date from MRIS will be inputted, but any discrepancies will be logged in the 'comments' field. Where DoD is not known on CRF01 and also not available from MRIS, date of death may be recorded from another source e.g GP or hospital.
- The WMAS "CPI" (Clinical Performance Indicator) reports also provide outcome data but this source has been known to be incorrect. Therefore if there is a death showing on this report, it will not be recorded on the database until concurrent information from other sources is received.
- To date, "location of death" is mostly left blank unless the patient was known to have died in hospital. This will be discussed by the TMG prior to analysis.



- “Death recorded = no” is only selected when a patient has been written to i.e. when sufficient checks have been made to verify the patient’s status. Therefore conflicts may exist temporarily between paper CRF02 and the database.

For cases where a match is not found on MRIS, a review will take place of how death was established (if deceased) and if any further checks are needed e.g if the registrar was the only source of death information. Details of the sources that are checked are recorded on the database. See also Working Procedure for Follow-Up (Section 1).

2.4.2 Monthly logic checks

Three reports have been set up for checking outcome data on a monthly basis:

- Status is “deceased” but “death recorded” = blank
- Check status for ‘transported to hospital’ = no and ‘declared deceased at ED’ = yes
- Date of death and date of cardiac arrest to be checked if the report shows “-“ (minus) days or “364-6” days, which could mean typo in the dates entered.

If the date of death is recorded as before the date of cardiac arrest, the CRF will be double checked in case of a data entry error. If the DoD on the CRF matches the database, the original source of death information will be double checked.

As data is entered, any missing data fields or confusing information is added to the individual Trust query lists straight away - see section 1.2.

2.4.3 Other data on CRF02

All CRF02 data that does not relate the primary outcome is checked against what is entered on the database on an ongoing basis. Where a hospital check is done information about discharge dates maybe entered in the comments, a report will be run to check and move any dates into the “discharge date field”. Patient addresses are also double-checked on an ongoing basis via 192.com and GPs before letters are sent to patients. Therefore this data will not be checked further as part of monitoring procedures.

2.5 Crew names/training details

A report query has been set up which pulls out a list of names/crew numbers in the database that only have a generic station (e.g West Midlands) to check if they should have been trained and assigned to a trial station. We will also run a report to check for duplicate names i.e the same person entered twice. The results of the reports will be sent to Research Fellows to find out if these crew have been trained. These checks will be done at least once before the end of recruitment.

We will also cross check a proportion (at least 10%) of names and corresponding training dates in the database against the training logs sent to us to check data entry is correct. Any errors will be corrected on the database and discussed with the Data Clerk, with further training of the Data Clerk if necessary.



2.6 Inbuilt database validation

The database contains inbuilt validation to ensure critical data is not missing and data is logical – details of this can be found in the FRS (<M:\Emergency CareTrials\PARAMEDIC\11.Data\Database\New Database\FRS>)

1.12.7 Validation/Range checks

The trial statistician will conduct range and validation checks to see if variables are in the expected range, as well as to assess completeness and whether dates are consecutive etc. (See table 2 and Statistical Analysis Plan)

2.8 Follow-up Questionnaires

2.8.1 Data Checking at WCTU (data entered on database against paper forms)

10% of follow-up questionnaires from each ambulance service will be randomly selected and double checked against what is entered on the database. Errors will be recorded on a spreadsheet (see section 1.3). If the error rate is found to be >5% a further 10% of questionnaires will be randomly selected and checked. Any errors will be amended on the database accordingly.

Any missing data from follow-up questionnaires identified after the visit is complete/questionnaire is received in the post will not be chased as it would not be appropriate to contact patients for this reason.

2.9 Oversight arrangements

2.9.1 Trial Management Group

Composition: Project staff, Investigators involved in the day-to-day running of the study. Please refer to the protocol for a current list of staff and Investigators.

Frequency: Monthly

Reason: Responsible for the day-to-day running of the study

2.9.2 Trial Steering Committee

Composition: Independent clinicians and trialists, lay representation, Investigators, Independent Chair

Frequency: Face to face meetings will be held at regular intervals determined by need but not less than once a year.

Reason: To provide overall supervision of the trial and ensure that it is being conducted in accordance with the trial protocol, principles of Good Clinical Practice and the relevant regulations.



2.9.3 Data Monitoring and Ethics Committee

Composition: Independent experts with relevant clinical research, and statistical experience. DMC meetings will also be attended by the Chief Investigators (for non-confidential parts of the meeting) and the trial statistician.

Frequency: every 6 months

Reason: To advise the trial steering committee as to whether there is evidence or reason why the study should be amended or terminated based on recruitment rates or safety and efficacy.

2.9.4 Investigators Meetings

The Investigators team will meet regularly throughout the trial, either face to face, by teleconference or through other means of communication.

Reason: These meetings will be to discuss set up, progress and close out of the trial.

2.9.5 Teleconferences with Ambulance Services

Frequency: at least quarterly

Who: Trial Co-ordinator, Trial Administrator, Lead Investigator (from Trial team); Lead Paramedic Research Fellow, Principal Investigator, other key contacts within the ambulance service.

Reason: To update on recruitment and compliance, and discuss any issues that arise.



3. Data Checking at Sites

3.1 Data Checking CRF01 against source

For source data verification, only the allocation i.e call sign and outcome fields (transported to hospital, CPR stopped, ROSC any time) will be checked at source by the Research Fellows, as many other fields are interpreted data which cannot be verified.

A spreadsheet consisting of case number, arrest date and station of 10% of eligible cases (randomly selected) from each ambulance service will be sent electronically to the Research Fellows. The Research Fellows will not be given the data that is already recorded in the database. They will be instructed to check data at source (i.e CAD/PRFs), not their CRF copies. We will compare this to what we've received previously (paper CRF01 and on the database). Any discrepancies will be discussed with the relevant Research Fellow to try and ascertain why there is an error. If the error rate is >5% within the ambulance service, a further 10% of cases will be randomly selected and checked by the Research Fellows at source. If the error rate is still >5% this will be discussed by the TMG to decide further actions.

Cases where there was uncertainty as to the eligibility of the patient (for example where two ambulances were first on scene simultaneously), will be looked at on a case by case basis.



3.1 Monitoring Plan

3.2.1 Site Master File

Site Master Files will be checked remotely before the end of the trial using the site file checklist:

<<**Site File Checklist** link here>>

To ensure they are up-to-date and contain all essential documents according to the Site Master File index (see SOP 11), sites will be asked for the latest version number they hold of each document. Any missing documents will be sent to sites to be filed in the Site File.

2.2.2 Site visits

The trial coordinator visited each Trust in the early stages of recruitment to check the consistency of staff training and answer any questions about the protocol, device or research in general. These visits are listed on the "Site Visit Log".

A final site visit will be carried out for each participating ambulance service trust to answer any questions on source data verification checks and Site Master File documents. No data checking or file checking will take place on these visits but particular attention will be given to storage of documents ready for archiving. A monitoring letter and report will be sent to sites after this visit.

3.2.3 Consent forms

As part of monitoring, consent forms will be checked by the Research Nurse to ensure they are completed correctly for every participant that agreed to be followed-up. The forms will be checked as they are received, and 100% of consent forms will be checked at the end of the study. If consent forms are not correctly completed, patients will not be contacted to complete another form as it would not be appropriate given the nature of the patient group but a file note will be written to explain any discrepancies.

Names of the trial team signing consent forms will be checked by the Research Nurse or Trial Administrator to make sure they are on the relevant ambulance services' delegation logs.

3.2.4 Training records

It is the participating ambulance service trust's responsibility to ensure competency assessment forms have been completed for each member of staff trained on LUCAS. This will not be monitored by CTU.

3.2.5 Device Tracking

A database is held at CTU to log when devices are sent to the Research Fellow, when they are put on the ambulance and when they are moved e.g to physio control. We also track when a device has been serviced, but rely on being told by the Research Fellows where devices are. Therefore this will not be formally monitored by WCTU.



3.2.6 Adverse Events

Any reported faults or incidents with the devices are recorded on Adverse Events forms – at monitoring visits we will confirm that all original Adverse Event documents are kept in the Site Master File. If they are not, copies will be sent out to sites to be filed.

Responsibility for tracking devices and logging faults stays with the Ambulance Services. The Ambulance Services report any faults to the Trial Co-ordinator on a CRF05 which is reviewed and signed off by the Chief Investigator.

At the end of the trial, we will reconcile which devices are with each Trust against our records of device location.

3.2.6 Vehicle Tracking

Research fellows send periodic reports of vehicle lists for their allocated area. This will not constitute part of monitoring carried out during the trial. Reports of vehicle location are primarily for checking vehicle randomisation balance in case of the need to randomise or re-randomise vehicles.

**Table 1. Outcome measures**

	Outcome	Source(s)	Acceptable error rate
Primary	Survival to 30 days	CRF01 (Q7b, Q7bvii) CRF02 (Q9) MRIS GP contact Hospital Registrar Summary Care Record	≤1%
Secondary	Survived event (sustained ROSC) with spontaneous circulation until admission and transfer of care to medical staff at receiving hospital	CRF01 (Q7bvi)	5%
	Survival to hospital discharge	CRF02 (Q7)	5%
	Survival to 3 and 12 months	CRF02 (Q9) MRIS GP contact	5%
	SF12 and EQ5D at 3 and 12 months	Follow-up	5%
	Neurologically intact survival to 3 months	Follow-up	5%
	MMSE at 12 months	Follow-up	5%
	HADS at 12 months	Follow-up	5%
	PCL-C at 12 months	Follow-up	5%
	Hospital length of stay	ICNARC/HES	5%
	Intensive care length of stay	ICNARC/HES	5%
Other data fields	CRF01	All other fields on CRF01	5%



Table 2. Checklist for the Validation Checks for PARAMEDIC TRIAL

Please note PART 2 Q5 onwards is only needed for eligible patients so will be blank for excluded cases.

Please note that only the grey shaded questions on CRF01 required for non-trial vehicles so all other questions in PART 1 and PART 2 will be blank.

		Check	Variables on database
PRIMARY OUTCOME	Date of death	Greater than DOB< Cardiac arrest date< date of death If transport to hospital=no, declared deceased = yes, DoD = date of cardiac arrest	
		999 call time is close to midnight, DoD might be next day?	
	Status	If status=deceased, death recorded=yes	
SECONDARY OUTCOMES	ROSC at any time	No missing data	
	Survival to hospital discharge	Date of hospital discharge >Date of hospital admission; Date of hospital discharge missing then date of death not missing;	
	Intensive care stay	Date of entry ICU < end of ICU If ICU missing then date of death not missing	
	Survival to 3 months	Every patient to have a status at 3 months (alive, death, withdrew or not reached and in the study)	
	Survival to 12 months	Every patient to have a status at 12 months (alive, death, withdrew or not reached and in the study)	



PROCESS DATA/OUTCOMES	Age	Date of cardiac arrest - DOB >0	Pcd_CardiacArrestDate -pat_DOB
		For eligible patients age >18	
		If DOB missing (unknown) then approx. age not missing; Approx. age > 18	
	Gender	Not missing (coded as 1 (male), 2 (female))	
	Pregnant	For eligible patients, patient not pregnant (1 - pregnant, 2- not pregnant)	
	Date of Cardiac Arrest date	Less than date of death (if died); Greater than DOB	tsc_date of death - Pcd_CardiacArrestDate Pcd_CardiacArrestDate -pat_DOB
	Response time	(At scene -999 Call time) >0	pcd_AtScene -pcd_CallTime
	Resusc time	At scene - CPR stop time >0	
	Time to hospital (1)	Time of arrival to hospital - time of EMS arrival at scene	Pcd_DestinationTimeCAD - pcd_AtScene
	Time to hospital (2)	Time of arrival to hospital - Time left scene	Pcd_DestinationTimeCAD - pcd_LeftScene
At patient time	At patient time > at scene time	Pcd_pat - pcd_AtScene	
Resuscitation attempt by EMS	If no: then one or more of the following has to be complete: (i) incompatible with life; (ii) DNAR or expected death; (iii) futility		



	Aetiology	If aetiology = 'others' then specify is non-missing	
	Location	If location = 'others' then specify is non-missing	
	Witness/Bystander	If 'witness' = 'yes', then one or more of the following should be ticked: (i) bystander, (ii) EMS or (iii) Non- EMS healthcare	
	Bystander CPR/defib	Non missing	
	Compliance	If LUCAS used =N, then one of the following has to be complete: (i) TBC, (ii) protocol confusion, (iii) patient too big, (iv) not trained, (v) crew decision, (vi) patient too small, (vii) forgot, (viii) no device, (ix) device failure, (x) others	
		If 'others' then 'specify' not missing	
	Initial rhythm	No missing data	
	Drugs given	No missing data	
	Intubated	No missing data	
	LMA/Supraglottis device	No missing data	
	Transport to hospital	If transport to hospital is 'no' then CPR stopped completed	
		If transport to hospital is 'yes' then (i) Time left scene completed;	



		(ii) hospital name completed; (iii) destination time (CAD) completed; (iv) hand over time completed.	
	Status at handover	No missing data	
	Patient declared deceased	No missing data	
	Other resource	Not missing	
	Region	Check station, call sign and crew are all from same region	
	Duplicate cases	Per region check for same cardiac arrest date and case number	
FOLLOW UP	Health related quality of life (EQ 5D and SF-12)	No missing item data and range checks	
	Mental Mini State examination	No missing item data and range checks	
	HADS scale	No missing item data and range checks	
	Post Traumatic Stress	No missing item data and range checks	

Appendix 8 Statistical analysis plan



Statistical Analysis Plan

Appendix 8: Statistical Analysis Plan



Pre-hospital Randomised Assessment of a Mechanical Compression Device in Cardiac Arrest

STATISTICAL ANALYSIS PLAN FOR THE PARAMEDIC TRIAL

Authors: PARAMEDIC Trial Team

Completion date:

Approved by:



CONTENT	Page
Aim and Design of the Trial	
1. Structure of the Statistical Analysis Plan	
2. Monitoring of the trial	
3. Statistical monitoring	
4. Statistical aspects	
5. Main Statistical Analysis	
6. Additional Statistical Analysis	
Appendices	



SECTION 1: AIMS AND DESIGN OF THE TRIAL

1.1 Trial design

PARAMEDIC is a cluster randomised controlled trial in the UK ambulance services. The vehicle (ambulances and rapid response vehicles (RRVs)) will be the units of randomisation.

1.2 Objectives

1.2.1 Primary objective

The primary objective of this trial is to evaluate the effect of using LUCAS rather than manual chest compression during resuscitation of a patient by paramedics after out of hospital cardiac arrest on mortality at 30 days after event.

1.2.2 Secondary objectives

Secondary objectives of the study are to evaluate the effects of LUCAS on survival to 12 months, cognitive and neurological outcomes of survivors and cost-effectiveness of LUCAS.

1.3 Eligibility criteria

1.3.1 Eligibility for clusters

Vehicles that are in service at each participating ambulance station and may attend eligible patients will be included in the trial and randomised to one of the trial arms, before the start of recruitment.



1.3.2 Eligibility for individual patients

Patients will be eligible if all 4 of the criteria below are met:

1. they are in cardiac arrest in the out of hospital environment;
2. the first ambulance resource is a trial vehicle;
3. resuscitation attempt is initiated by the attending ambulance clinicians, according to JRCALC guidelines;
4. the patient is known or believed to be aged 18 years or over.

Exclusion criteria will be:

1. cardiac arrest caused by trauma
2. known or clinically apparent pregnancy

1.4 Outcome measures

1.4.1 Primary outcome:

Survival to 30 days post cardiac arrest.

1.4.2 Secondary outcomes:

- Survived event (sustained return of spontaneous circulation (ROSC), with spontaneous circulation until admission and transfer of care to medical staff at the receiving hospital)
- Survival to hospital discharge
- Hospital length of stage
- Intensive care length of stay
- Survival to 3 and 12 months
- Health related quality of life (SF12 and EQ-5D) – 3 and 12 months
- Neurologically intact survival (survival with CPC score 1 or 2)- 3 months only
- Cognitive outcome months (Mini Mental State Examination (MMSE))- 12 months only
- Anxiety and depression (Hospital Anxiety and Depression Scale (HADS)) – 12



months only

- Post Traumatic Stress (PTSD civilian checklist (PCL-C)) – 12 months only

An economic evaluation will also be conducted, and is described in a separate analysis plan.

1.4.3 Safety

Adverse events and device related adverse event will be reported.



SECTION 2: MONITORING OF THE TRIAL

Monitoring of the trial is a continual process, from the start to the end of the study. At the end of the trial two aspects related to monitoring will be examined:

- (a) Operational (logistical) and Process Management monitoring;
- (b) Statistical monitoring (assessment of bias – as stated in the protocol).

2.1 Operational (logistical) and Trial Management of Ambulance Stations

- There are 4 *regions* recruiting patients to the PARAMEDIC trial: West Midlands, Wales, North East and South Central.
- Within the regions are the local areas (*locality*) and within the localities are the *ambulance stations*, where vehicles have been randomised to the trial.
- The status of the recruiting ambulance stations will be detailed (as in Table 1.1).

2.2 Operational (logistical) and Trial Management monitoring of vehicles

2.2.1 Number of vehicles and its impact on the Sample Size

- The observed number against what was expected for the number of vehicles will be stated and its effect on the overall sample and intra cluster correlation coefficient.



2.2.2 Vehicle Movement and Rotation

- There are many processes in the PARAMEDIC trial that need to be monitored regularly and at the end of the trial -in order to make the trial a success. This will highlight any areas which have been problematic and may have introduced bias.
 - (a) Not all vehicles are randomised in a station. Non-randomised vehicles may attend cardiac arrests. The number of non-randomised vehicles will be summarised as a proportion of all vehicles in a station/area.
 - (b) Some vehicles are likely to be randomised in a region and can sometimes be moved to another region, end up in workshop (trial or non-trial) or scrapped.
 - (c) Some vehicles are randomised but never attend a cardiac arrest, and this means that the randomised devices are held up and never get used. Also for the sample calculation purposes, we have assumed that on average each randomised vehicle will attend at least 15 cardiac arrests.

The above will mean that randomised vehicles are less likely to attend cardiac arrests, in the presence of non-trial vehicles and it is important to ensure that randomised vehicles keep within their region when rotation occurs.

Summary of vehicle movement and rotation

1. Number of vehicles (randomised and non-randomised) within each vehicle type and each region (TABLE 2.1).
2. Number (and percentage) of vehicles RANDOMISED by the type of vehicle and intervention within each region - (TABLE 2.2) and FIGURE 2.1 (CONSORT Diagram).



4. Number (and percentage) of CURRENT vehicles by the type of vehicle and intervention within each region (after removal/change in allocation/change to another region) (TABLE 2.3 and TABLE 2.4).

6. Randomised vehicles attending number of cardiac arrests (TABLE 2.5 and TABLE 2.6).

2.3 Operational (logistical) and Trial Management monitoring of patients

2.3.1 Recruitment of patients

- Patients recruited within region/locality are detailed in Table 1.1.
- The average number of patients within each vehicle will be detailed.
- A recruitment graph showing the number of vehicles (control and LUCAS) recruited with the number of patients recruited over the entire study period will be illustrated (PLOT 1.1).

2.3.2 Distribution of patients within each region

- TABLE 3.1 through to TABLE 3.4 illustrate the distribution of patients within regions.

2.3.3 Violations or deviation from the protocol

- Protocol violators/deviators will fall into one of the following categories (tabulated in Table 3.3):
 - (i) Patients who receive an intervention different from that allocated to first vehicle in attendance;
 - (ii) Withdrawals;
 - (iii) Ineligible patients – any patient who was ineligible but subsequently received treatment from one of the randomised vehicles (and interventions).



-
- Withdrawals from the trial may occur during follow-up. All withdrawals will be summarised by treatment arm. Also all data up to the time of withdrawal will be used for the analysis (ITT).

2.3.4 *Non-compliance*

- Those in category (i) above make up the non-compliance group. These are further broken down into those listed in Table 3.5.
- The reasons for non-compliance as given in Table 3.5, can be split into two main groups:
 - Trial specific non-uses of LUCAS: There are other reasons for non-use of LUCAS which are trial specific, and would not occur if the device should have in clinical practice. These include (a) crews not trained in use of the device, (b) crew error (protocol confusion or no device in vehicle or crew forgot or the device having been removed erroneously from the vehicle).
 - As encountered in normal clinical practice: These include (a) unsuitable patient (patient was too big or too small), (b) device issues (device failure), (c) not possible to use LUCAS (either because of space restrictions, or because the cardiac arrest occurred after attendance of a solo responder who did not take the LUCAS to the patient). Such cases are part of the real-world treatment effect of LUCAS and are appropriately included in analysis of a pragmatic trial.
- These two groups are included in the sensitivity analysis for this study (see section 5.2.4).
- At the beginning of the trial, the rate of non-compliance is considered as 100%, and as each non-compliant patient enters the trial through time, the rate of non-compliance will decrease. This rate can be plotted against days of survival on a Kaplan-Meier curve for those on the LUCAS arm. This will allow us to assess the relationship of survival with the rate of non-compliance.



2.3.5 Status of patients in the trial from prior to hospitalisation to follow-up

TABLE 3.5 illustrates the status of patients in the trial, at the end of the study.

2.3.6 Follow-up rates

The follow-up rates will be derived from information presented in Table 3.5.

2.3.6 Safety Data

Device related events and serious adverse events will be summarised in a listing (by intervention).



SECTION 3: STATISTICAL MONITORING

3.1 Statistical monitoring (assessment of bias)

- Ambulance crew who deliver the interventions are not blinded to the allocation, and therefore there is a possibility that bias could be introduced by different thresholds for resuscitation between LUCAS and the standard care arms. Appendix 1 details the staff involved in the trial and whether they are blinded/un-blinded to the treatment allocation.
- Table 4.1 illustrates the variables which will be assessed to detect any bias introduced into the trial: assessment of characteristics of patients recruited to the LUCAS and manual compression arms, where cardiac arrests occurred and no resuscitation/ resuscitation was made.
- The data on the characteristics of patients (for assessment of bias) is reported to the DMC on a 3 monthly basis. The DMC assesses these for any variables that may exceed potential thresholds (as judged by the clinical experts). Table 4.1 will also be produced at the end of the trial.
- In addition the following will be summarised for monitoring purposes:
 - Proportion of arrests where resuscitation attempted: cardiac arrests attended;
 - Age (summary statistics);
 - % bystander CPR;
 - Time of 999 call to trial vehicle arrival;
 - Proportion of patients in asystole.



3.2 Intra cluster correlation coefficient and sample size

- Several patients are likely to be attended by one vehicle. In theory this gives rise to the fact that there is a grouping component (by the vehicle) which may indicate that outcome is correlated among patients who have been attended by a particular vehicle. However, in practice, all vehicles are mechanical objects and there are no subjective factors which distinguish them. Furthermore, different personnel and rotation of staff would mean that the different paramedics are likely to attend cardiac arrest, using one vehicle, at least some of the time, suggesting that any clustering effects will be negligible.
- However the intra cluster correlation coefficient will be obtained using the primary outcome.
- The intra cluster correlation coefficient will be computed for every DMC report and its impact will be assessed on the sample size.
- Event (survival status) at 30 days is the primary outcome and can be interpreted as binary (death/alive) at that time point. Chakraborty (Contemporary Clinical Trials 30 (2009) 71–80) specify the formulation of an ICC based on binary outcome together with the 95% confidence interval. This will be used in computing the ICC estimate.

3.3 Sample size and non-compliance

To ensure the required sample size is achieved, we will monitor non-compliance and its impact on the sample size/effect size that is required.



Statistical Analysis Plan

SECTION 4: STATISTICAL ASPECTS

4.1 Outcome Variables

OUTCOMES	TIME POINT	SCORING
Primary outcome		
Survival	30 days post cardiac arrest	
Secondary outcomes		
Survival event (sustained return of spontaneous circulation (ROSC))	Until admission and transfer of care to medical staff at the receiving hospital	
Survival to hospital discharge	The point at which the patient is discharged from the hospital acute care unit regardless of	



Statistical Analysis Plan

	neurological status	
Survival	To 3 months and to 12 months	
Health related quality of life- SF-12	At 3 months and at 12 months	As in the SF-12 manual: How to Score version 2 of the SF-12 Health Survey. Two provided : Physical and mental components.
Health related quality of life- EQ-5D	At 3 months and at 12 months	Summary of each item given and the VAS score (out of 100) summarised. The EQ-5D utility score will be obtained by the Health Economist.
Neurological intact survival (survival with CPC score 1 or 2)	To 3 months	The CPC score is measured on a 5-point scale. However, it is generally acceptable to split these into two categories: good neurological outcome (CPC score: 1-2) and poor neurological outcome (3-5).
Cognitive outcome (Mental Mini State Examination)	At 12 months	Each item scores a 1 if it is correct or 0 if incorrect. The total score is summated and the maximum score is 30. Cut-off are: 0-10: severe, 10-20: moderate, 20-25: mild, 25-30: questionably significant.
Anxiety and depression score (Hospital Anxiety and depression scale)	At 12 months	There are 14 items: 7 relate to anxiety and 7 relate to depression. Responses are summed to provide separate scores for anxiety and depression, with possible scores ranging from 0 to 21 for each scale



Statistical Analysis Plan

		Higher scores indicate likelihood of anxiety and/or depression. Recommended cut-off are : 8-10 (mild); 11-15(moderate) and 16 or above (severe)
Post Traumatic stress (PTSD civilian checklist (PCL-C))	At 12 months	Respondents rate each item from 1 ('not at all') to 5 ('extremely') to indicate the degree of the symptoms over the past month. Thus the total will range from 17 to 85. Weathers et al (1993) recommended a cut-off score of 50 as optimal for indicating a probable of combat-related PTSD.
Hospital length of stay	Up to hospital discharge	
Intensive care length of stay	Up to ICU discharge	

4.2 Type of populations

4.2.1 Intention to treat (ITT) Population

An ITT analysis would measure something more important than intervention efficacy, namely intervention policy. That is, it tests whether it is better to *prescribe* LUCAS than manual CPR (i.e. an ‘as-randomised analysis’ or intention to treat (ITT) compares the outcomes of participants by assigned group). The ITT effect is the effect of treatment assignment rather than the effect of treatment taken (often called ‘effectiveness’ as opposed to ‘efficacy’). A full ‘Intention-to-treat’ analysis is only possible when complete outcome data are available for all patients. One of the main reasons for advocating ITT analysis is that it gives an estimate as would be in the ‘real world’ and it also maintains the baseline comparability achieved by the randomisation process. If the initial random assignment is undermined, then confounding can be introduced and the internal validity of the results is consequently questionable.

4.2.2 Complier average causal effect (CACE)

The ‘Complier average causal effect’ (CACE) is the intervention effect among the true compliers; the difference in outcome between compliers in the treatment group and those controls who would have complied with intervention had they been randomised to the treatment group. Complier average causal effect (CACE) is a measure of the causal effect of the intervention on the patients who receive it as intended by the original group allocation. Because it retains the randomisation assignment, it overcomes the problems related to per-protocol and on-treatment analysis.

CACE analysis makes two assumptions; the first is that members of the control group have the same probability of non-compliance as members of the intervention arm. If allocation is genuinely random, this statement must be accepted as true. This second is that merely being allocated to the intervention has no effect on outcome; i.e. outcomes are the same for participants who were not treated with LUCAS in both the LUCAS and control arms. Both of these assumptions appear reasonable for this trial.

4.2.3 Proposed analysis strategy

In section 2.3.4, reasons of non-compliance were divided into two groups: those that were 'true non-compliers' and those which in a pragmatic setting could be considered as compliers.

In terms of analyses, we propose to use the following to estimate the effects of LUCAS. There will be two primary analyses.

PRIMARY ANALYSES:

- (i) *Intention to treat analysis (PRIMARY):* This will include all patients recruited to the study.
- (ii) *Modified CACE analysis (PRIMARY):* In this analysis, 'non-compliers' in the LUCAS arm will be defined as cases where non-compliance was due to: (a) crew not trained in use of the device, (b) crew error (protocol confusion or crew forgot) or (c) no device in the vehicle (the device having been removed erroneously).

SECONDARY ANALYSES:

- (iii) *CACE analysis:* In this analysis all 'non-compliers' will be defined as 'all cases that did not receive their allocated intervention' i.e. LUCAS was not used if allocated to LUCAS, or LUCAS was used if allocated to control.

4.3 Analysis Datasets

Usually there are two datasets used for the statistical analysis (within each of the analyses populations stated in section 5): (a) Observed and (b) imputed.

For the primary outcome and data collected prior to hospital discharge only the observed datasets will be used for the ITT and 'CACE' analysis. This is because we cannot assume 'randomness' about the 'missing' data for these outcomes (i.e. death may be more associated with patients who have poor prognosis as will cardiac arrest outcomes).

However, follow-up data on questionnaires (SF-12 and EQ-5D) will be imputed for completeness.

4.3.1 Observed dataset

This will comprise of all the data observed (including follow-up) with missing values. The data will also include a variable to indicate what treatment patients were randomised to and another variable to indicate what treatment they actually received so that the 'ITT' and 'CACE' analyses can be implemented.

4.3.2 Imputed dataset

Data will also be imputed to form a dataset to be used for a sensitivity analysis for the follow-up questionnaires.

Data can be missing in fields in two situations: (a) when it is not applicable (validly missing) and (b) it can be missing due to patient/health professional leaving fields blank when they should have completed the question with an answer (invalidly missing). The latter will be examined for the different data mechanisms (MAR - missing at random; NMAR - not missing at random; MCAR - missing completely at random) and we will assess whether multiple imputation is viable. In the case where multiple imputation can be used and the data can be assumed normal, multivariate methods will be applied. In the case where one cannot assume a distribution of the data, the ICE (imputation by chain equations) will be used.

SECTION 5: MAIN STATISTICAL ANALYSIS

5.1 Demography of patients and Cardiac arrest population

Table 4.1 illustrates the patient characteristics of all patients approached and those who are eligible.

Table 4.2 displays the patient characteristics of eligible patients by intervention arm.

The tables illustrate the statistics for the compliers and non-compliers. No statistical analysis will be done for these tables.

5.2 Outcome Data

Unadjusted and adjusted estimates of the treatment effect will be obtained, with the 95% confidence intervals.

The analysis will be adjusted to take account of imbalance in factors (such as presenting rhythm, time since 999 call and presence of bystander CPR. Other factors which will be adjusted for will be age and gender.

The statistical analysis will be carried out using SAS (version 9.3.1) and STATA 11.

5.3 Primary outcome data

The primary outcome will be summarised as in Table 6.3. There is very little data where the outcome at 30 days is not known. For this reason, the data will be treated as a dichotomous without any censoring. The analysis will be carried out an intention to treat basis, as well as CACE and modified CACE.

ITT analysis

Assuming clustering effects: If there is noticeable clustering effect (as assessed with the intra cluster correlation coefficient), among the vehicles then this will need to be accounted for in the analysis. This will be done in SAS using GLIMMIX, where the vehicle (unit of randomisation) will be included as a random effect. Section 3.2 details the methods for assessing an ICC, which will quantify the clustering effect.

Assuming no clustering effect: Logistic regression models will be used to model the status of survival at day 30 (dead/alive), accounting for covariates such as age and gender.

Modified CACE and CACE data

Assuming clustering effects: For the modified CACE and CACE analysis, random effect model computing the Nagelkerke's estimate (1) will be used.

Assuming no clustering effects: For the modified CACE and CACE analyses, logistic regression models which are modified to allow for compliance/non-compliance effect will be used (based on the Nagelkerke's estimate (1)).

5.4 Secondary outcomes – up to hospital discharge

Tables 4.5 and 4.6 display the variables collected up to the point of hospital entry.

5.4.1 Sustained return of spontaneous circulation (ROSC)

ROSC will be summarised by each treatment arm (as in Table 4.6a) and summarised by each treatment arm and the type of compliance/non-compliance (Tables 4.6b and 4.6c).

Intention to treat: ROSC will be analysed using random effect logistic regression model (if clustering is present) or ordinary logistic regression model (if no clustering effect is present).

Modified CACE and CACE analysis: ROSC will be analysed using logistic regression models which are modified to allow for compliance/non-compliance effect (based on the Nagelkerke's estimate (as above)).

5.4.2 Survival to hospital discharge

Intention to treat: Table 4.7a summarises the summary statistics for survival to hospital discharge. The number of patients surviving/died at hospital discharge will be summarised and analysed using random effect logistic regression models (where there is clustering) or the usual logistic regression model (where there is negligible clustering).

Time to hospital discharge will be analysed using survival methods. In particular survival analysis which allows for random effect (namely frailty models) will allow for

the clustering component. In the case where there is very little clustering effect, the usual survival analysis (Cox's proportional hazards model) will be used.

Modified CACE and CACE: Table 4.7b and 4.7c illustrate the summary statistics for survival to hospital discharge, by intervention and by compliance/non-compliance. The above methods (as for the primary outcome) will be used allowing for compliance/non-compliance.

5.4.3 *Length of intensive care and hospital stay*

Intention to treat: Table 4.8a illustrates the length of intensive care and hospital stay. The length of intensive care and hospital stay will be summarised using mean, standard deviation and median values. These data will be analysed using random effect models (to account for clustering) or the using linear regression model (where the clustering effect is negligible).

Modified CACE and CACE: Table 4.8b and 4.8c illustrate the summary statistics for length of stay of intensive care and hospital stay, by intervention and by compliance/non-compliance. The above methods (as for the primary outcome) will be used allowing for compliance/non-compliance. These methods can be adapted for linear regression models.

5.5 Secondary outcomes – during follow-up

5.5.1 *Survival to 3 and 12 months*

Tables 4.9 (a, b and c) and 4.10 (a, b and c) illustrate survival status at 3 and 12 months.

Survival to 3 and 12 months (post cardiac arrest) will be assessed in a similar way as survival to 30 days (post randomisation).

5.5.2 *Health related quality of life – SF -12 (3 and 12 months)*

The health related quality of life SF-12 assessments (physical and mental components) will be summarised by intervention (as in Tables 4.11a, 4.11b and 4.11c) for 3 and 12 months.

The analysis of the SF-12 components will be similar to that for the length of stay (in ICU and hospital) as stated above, at each time-point.

5.5.3 Health related quality of life – SF -12 (3 and 12 months)

The health related quality of life EQ-5D assessments will be summarised by intervention (as in Tables 4.12a, 4.12b and 4.12c) for 3 and 12 months.

There will be no analysis for the items, however the VAS EQ-5D score will be analysed in a similar way to length of stay (in ICU and hospital) as stated above, at each time-point.

5.5.4 CPC scores(neurological intact survival) 3 months

The CPC scores will be summarised over the two interventions at 3 months, as given in Tables 4.13 (a, b and c).

The analysis of these scores will be using ordinal regression models.

5.5.5 Cognitive outcome (MMSE)

The cognitive outcome (MMSE) at 12 months will be summarised as displayed in Tables 4.14 (a, b, and c).

The analysis of the MMSE will be similar to that stated above for length of stay (in ICU and hospital stay).

5.5.6 Hospital Anxiety and Depression score (HADS)

The Hospital Anxiety and Depression score (HADS) at 12 months will be summarised as displayed in Tables 4.14 (a, b, and c).

The analysis of the HADS will be similar to that stated above for length of stay (in ICU and hospital stay).

5.5.7 Post Traumatic Stress (PTSD civilian checklist (PCL-C))

The Post Traumatic Stress (PTSD checklist) at 12 months will be summarised as displayed in Tables 4.14 (a, b, and c).

The analysis of the PTSD checklist will be similar to that stated above for length of stay (in ICU and hospital stay).

5.6 Sub-group Analyses

Six pre-specified sub-group analyses will be conducted:

- Cardiac arrest witnessed by crew/witnessed by public versus not witnessed;
- Bystander CPR versus no bystander CPR;
- Type of initial rhythm (VT/VF versus PEA/Asystole);
- Presumed cardiac aetiology of cardiac arrest (CPC score 1,2 versus 3,4,5)
- Type of vehicle (ambulance versus RRV)
- Ambulance service

These sub-group analyses will be conducted on the ITT (detailed in Tables 4.15-4.19). They will involve modelling the primary outcome as the independent variable and interaction of treatment and covariate of interest. Thus the modelling will be based on logistic regression and will be analysed in a similar way to the primary outcome (depending on whether clustering is present or not).

Further sub-group analyses will involve:

- Age
- Time interval from 999 call to arrival of the trial vehicle

These variables will be treated as continuous and therefore multivariable polynomial interaction (MPFI) technique will be used to assess the effect of treatment and covariate interaction.

SECTION 6: ADDITIONAL STATISTICAL ANALYSIS

6.1 Training of Paramedics/Learning Effects/Crew Preference

All clinician staff will be treated in the trial procedures, to ensure that they understand the rationale for the trial and the importance of following the trial procedures correctly. The training will include a review of existing evidence so that participating ambulance clinicians understand the current position of equipoise regarding the effectiveness of LUCAS and discussion of potential sources of bias in the trial and the importance of applying the inclusion/exclusion criteria rigorously to both arms.

Training will continue throughout the recruitment period to ensure that any new staff members are trained before recruiting and that important messages are continually reinforced.

1. *Training of the Paramedics:* The percentage of crew trained (of all those trained to date at one round of training), the percentage of LUCAS uses (of all CAs attended by CPR and LUCAS) and the percentage survival (on LUCAS) will be plotted over the course of the study, i.e. by 3 monthly intervals (PLOT 2.1). This will illustrate a relationship between the increase in training, and use of LUCAS and its impact on survival. This plot will be done over the entire trial (i.e. time-points) and by localities.

2. *For compliance and non-compliance (separately):* The number of days from training to first use of LUCAS will be plotted against the percentage of LUCAS use for each paramedic. This will illustrate whether there is a relationship between lapse in time from training and the how often paramedics use the LUCAS device (PLOT 2.2).

3. *Learning effects:* A paramedic may have been trained to use the LUCAS device, but because he is part of a team, he may have not used it on a patient or his use of the device will be limited. Also, we only know of a team attending a cardiac arrest and its outcome, we do not know which paramedic administered the device. For this reason it would not be possible to look at learning effects within a paramedic. Also, team members that form teams differ all the time and again it would not be possible to look at the learning effects within teams. However, PLOT 2.1 above will inform us to some extent about the increase in the use of LUCAS over time and its effect on survival. Although this does not measure learning effects directly, it does provide some information about whether the

outcome is getting better when the familiarity with the LUCAS device has increased across the trial.

4. *Crew preference*: the date of training will be plotted against the number of LUCAS uses for each paramedic (PLOT 2.3). One would expect to see a negative relationship: the earlier the date of training the more incidences a paramedic will have attended where the LUCAS was used. Any outliers, e.g. the later trained crew members who show a large number of incidences of cardiac arrests where LUCAS was used, may be valid, but will be investigated to eliminate any suspicious of crew preference.

The number of times a particular paramedic is present in a non-compliance case when using LUCAS will be summarised. Those who show a high incidence will be investigated. This will illustrate the presence of the paramedic when the LUCAS was not used according to the protocol. It will not directly indicate that the paramedic had lack of preference to the LUCAS device.

6.2 Monitoring Device Usage

Quality of CPR (via manikins, via defibrillators and all devices)

- The data collected on the manikins (ventilation: average volume, average per min; average depth: average per minute) will be used to compute the chest compression fraction.
- The quality of CPR via defibrillators will be assessed using the chest compression fraction obtained from the data on these devices (namely , time switched on to 1st compression, time from 1st compression to last compression, total time in pause, duration in 30:2, duration in continuous).
- Data obtained from all devices will lead to the computation of the chest compression fraction.

For each of these methods, the chest compression fraction will be summarised and where required cross referenced.

REFERENCE

N. Nagelkerke, V. Fidler, R. Bernsen, M. Borgdorff, Estimating treatment effects in randomized clinical trials in the presence of non-compliance, *Statistics in Medicine*, 2000, 19: 1849-1864

APPENDICES

APPENDIX 1

PARAMEDIC trial - Allocation concealment and blinding

In the PARAMEDIC study, failure to conceal the process of random allocation will potentially result in a non-randomised trial, while successful allocation concealment will reduce selection bias. Currently the method of randomisation is randomly allocation of vehicles using a ratio of 2:1 (control: LUCAS) with type of vehicle (vehicle or RRV) as strata. The following personnel will be blinded/unblinded to the allocation:

<i>UNBLINDED</i>	<i>BLINDED</i>
<i>Vehicle clinicians cannot be blinded and will be aware of the allocation.</i>	<i>Control room personnel will be blinded to the allocation of the vehicles, to ensure that no bias in whether a LUCAS or control vehicle is sent, which will give equal chance that a LUCAS or control will attend.</i>
<i>Clinical trial co-ordinators/managers and data entry staff will be aware of the allocation due to the format of the CRF</i>	<i>Patients themselves will be unaware of their treatment allocation at the time of the intervention- though they may subsequently be unblinded by relatives/friends.</i>
<i>Statistician will produce and hold the treatment allocation.</i>	<i>Chief Investigators and investigators (in the Trial Management Group) in the trial will not be aware of the allocation. No data reports based on outcomes are provided by treatment allocation for trial staff.</i>
	<i>Research nurses assessing outcome at 3 and 12 months follow-up will be blinded to treatment group and will endeavour to maintain their blinding during the follow-up assessments.</i>
	<i>The Independent Data Monitoring Committee (IDMC) will be provided with data reports on outcomes detailed by</i>

	<i>intervention allocation, but the allocation will be blinded and should the IDMC deem necessary, the treatment allocation can be unblinded for them.</i>
	<i>The Trial Steering Committee do not seem any data report on the outcomes and therefore remain unblind to the allocation</i>

Blinding

In the usual conventional clinical trial setting, it is important to ensure that patients, investigators and those collecting the data are unaware of the assigned treatment, so that they will not be influenced by that knowledge.

In PRE-FIT, it is not possible to blind the patient or the investigator from the allocated intervention. However, it is possible to ensure that the data management team are blinded from the allocation of the intervention.

Details of how the data management team will ensure blinding.

Appendix 9 Systematic review search strategy

MEDLINE search strategy

1. exp Heart Arrest/
2. exp Death, Sudden/
3. cardiac arrest.tw.
4. heart arrest.tw.
5. cardiopulmonary arrest.tw.
6. sudden cardiac death\$.tw.
7. sudden death\$.tw.
8. or/1-7
9. exp Cardiopulmonary Resuscitation/
10. Heart Massage/
11. cpr.tw.
12. cardiopulmonary resuscitation.tw.
13. chest compression\$.tw.
14. resuscitat\$.tw.
15. or/9-14
16. Cardiopulmonary Resuscitation/is [Instrumentation]
17. autopulse.tw.
18. auto-pulse.tw.
19. thumper.tw.
20. lucas.tw.
21. hands-free.tw.
22. (pneumatic adj10 (pump or device)).tw.
23. (pneumatic adj10 compression\$.tw.
24. (automat\$ adj10 compression\$.tw.
25. (device\$ adj10 compression).tw.
26. (mechanical adj10 compression\$.tw.
27. (machine\$ adj10 compression\$.tw.
28. piston\$.tw.
29. load distributing.tw.
30. (vest adj10 compression).tw.
31. (mechanical adj10 cpr).tw.
32. (pneumatic adj10 cpr).tw.
33. (device adj10 cpr).tw.
34. (machine\$ adj10 cpr).tw.
35. (vest adj10 cpr).tw.
36. or/16-35
37. 8 and 15 and 36
38. randomised controlled trial.pt.
39. controlled clinical trial.pt.
40. randomized.ab.
41. placebo.ab.
42. drug therapy.fs.
43. randomly.ab.

44. trial.ab.
45. groups.ab.
46. 38 or 39 or 40 or 41 or 42 or 43 or 44 or 45
47. exp animals/ not humans.sh.
48. 46 not 47
49. 37 and 48

Appendix 10 End-of-study information sheet



*Pre-hospital Randomised Assessment of a
Mechanical Compression Device*

Information Sheet for Trial Participants

BACKGROUND

Each year around 30,000 people in the United Kingdom suffer out of hospital cardiac arrests and less than one in ten of those return home alive.

Early high quality Cardio- Pulmonary Resuscitation (CPR) is critical to survival. However maintaining high quality chest compressions during resuscitation is difficult for crews of emergency vehicles due to crew numbers, fatigue etc and it is particularly difficult in moving vehicles.

1.022^{rev} June 2015

A number of mechanical devices, suitable for use outside a hospital have been developed over the years to improve the quality of chest compressions and therefore attempt to improve patient outcomes.

However purchasing sufficient devices to go on all NHS front line ambulances would cost in the region of £40-50 million pounds, plus additional annual maintenance and training costs of several million.



Before the NHS invested millions of pounds in mechanical CPR devices the Joint Royal College Ambulance Liaison Committee and Resuscitation Council (UK) called for research to work out if mechanical chest compression devices were better than the manual CPR provided by trained NHS paramedics.

The University of Warwick Clinical Trials Unit initiated the Pre Hospital Randomised Assessment of a Mechanical Compression Device in Cardiac Arrest Trial (PARAMEDIC-1) in partnership with Coventry and Surrey Universities, West Midlands, North East, South Central and the Welsh NHS Ambulance Services. The PARAMEDIC-1 trial evaluated the LUCAS-2 mechanical chest compression device.

WHAT WE DID

The trial took place across four Ambulance Services which serve a population of 1 million people over 24,000 square miles. Emergency vehicles (rapid response and standard ambulances) from 91 ambulance stations were



allocated to carry a LUCAS-2 device or to continue with current standard treatment (manual chest compressions). If the first ambulance to arrive had a LUCAS-2 device the crew were able to use it. If the first ambulance did not contain a LUCAS-2 device then standard manual CPR was provided by the highly trained NHS Paramedics.

The primary purpose of the trial was to see if more people would be saved by using the mechanical chest compressions (LUCAS-2) compared to ambulance paramedics performing standard manual chest compressions using their hands.

Between April 2010 and June 2013 a total of 418 emergency vehicles were involved in the trial of which 287 were double manned ambulances and 131 single manned rapid response vehicles.

The emergency vehicles involved in the trial attended 11,171 potential cardiac arrest patients and the proportion of cases where resuscitation was attempted was 41% and this was similar in both groups.



A total of 4471 patients were enrolled in the study of which 1652 were in the group where emergency vehicles carried the LUCAS-2 device.

A total of 985 patients were treated with the device. Patients who were known, or believed to be under 18 years of age, those known or apparently pregnant and cases where the cardiac arrest was the result of trauma were not eligible for the trial and received standard treatment.

1.022nd June 2015

WHAT WE FOUND

The main result of the study was that there was no significant difference found between the control and experimental groups.

The study provides reassurance that the high quality treatments delivered by NHS Ambulance Paramedics cannot be beaten by a machine.

The study helps remind us of the importance of focusing on simple treatments that are proven to save lives – those being someone starting CPR prior to the ambulance arriving, early de-fibrillation and a rapid response by the ambulance service.

THANK YOU

The study team are very grateful for the help and co-operation from the study participants, their families and friends, and the Ambulance staff who worked so hard to make the study a success.

Further information about the trial can be found at: www2.warwick.ac.uk/paramedic



UNIVERSITY OF
SURREY



Warwick
Medical School
CLINICAL TRIALS UNIT

NHS
National Institute for
Health Research

A decorative graphic consisting of numerous thin, parallel green lines that curve from the left side of the page towards the right, creating a sense of movement and depth.

**EME
HS&DR
HTA
PGfAR
PHR**

Part of the NIHR Journals Library
www.journalslibrary.nihr.ac.uk

This report presents independent research funded by the National Institute for Health Research (NIHR). The views expressed are those of the author(s) and not necessarily those of the NHS, the NIHR or the Department of Health

Published by the NIHR Journals Library